

Motion Controller

GM1 Series

Reference Manual

Hardware

(MEMO)

Introduction

Thank you for purchasing a Panasonic product. Before you use the product, please carefully read through the installation instructions and the manuals, and understand them in detail to use the product properly.

Types of Manual

- There are different types of manuals for the GM1 series, as listed below. Please refer to a relevant manual for the unit and purpose of your use.
- The manuals can be downloaded from our website: <https://industrial.panasonic.com/ac/e/motor/motion-controller/mc/gm1/index.jsp>.

Manuals for GM1 series

Manual name	Manual code	Description
GM1 Controller RTEX User's Manual (Setup Edition)	WUME-GM1RTXSU	Explains wiring between the GM1 and its peripheral devices, installation method, and operation check method.
GM1 Controller EtherCAT User's Manual (Setup Edition)	WUME-GM1ETCSU	
GM1 Controller RTEX User's Manual (Operation Edition)	WUME-GM1RTXOP	Explains how to use GM Programmer and PANATERM Lite for GM, set up each function, create projects, and perform other operations.
GM1 Controller EtherCAT User's Manual (Operation Edition)	WUME-GM1ETCOP	
GM1 Series Reference Manual (Hardware Edition)	WUME-GM1H	Explains the functions and performance of each GM1 unit.
GM1 Series Reference Manual (Instruction Edition)	WUME-GM1PGR	Explains the specifications of each instruction that can be used with the GM1 Series.
GM1 Series Reference Manual (Analog I/O Unit)	WUME-GM1AIO	Explains the functions and performance of the GM1 Analog Expansion Unit.
GM1 Series Reference Manual (Pulse Output Unit)	WUME-GM1PG	Explains the functions and performance of the GM1 Pulse Output Unit.

Copyright / Trademarks

- The copyright of this manual belongs to **Panasonic Industry Co., Ltd.**
- Unauthorized reproduction of this manual is strictly prohibited.
- Windows is a registered trademark of Microsoft Corporation in the U.S. and other countries.
- Ethernet is a registered trademark of Fuji Xerox Co., Ltd. and Xerox Corporation.
- EtherCAT is a registered trademark of and patented technology licensed by Beckhoff Automation GmbH, Germany.
- EtherNet/IP is a registered trademark of ODVA (Open DeviceNet Vendor Association).
- SDHC and SD logos are trademarks of LLC.
- Other company and product names are trademarks or registered trademarks of their respective companies.

(MEMO)

Table of Contents

1 Before Using This Product	1-1
1.1 Safety Precautions.....	1-2
1.2 Handling Precautions.....	1-3
2 Overview (System Configuration)	2-1
2.1 Basic System Configuration.....	2-2
2.1.1 Outline of the GM1 System.....	2-2
2.1.2 Unit Types	2-2
2.1.3 Restrictions on the Number of Expansion Units	2-3
2.2 Restrictions on the GM1 Controller and Servo Amplifiers.....	2-5
2.2.1 Restrictions on the Combination of the GM1 Controller and Servo Amplifiers	2-5
2.2.2 Restrictions on Servo Amplifier Parameters	2-6
2.3 Programming Tools.....	2-8
2.3.1 Software Usage Environment and Applicable Cables	2-8
3 Names and Functions of Components	3-1
3.1 Names and Functions of Components of the GM1 Controller	3-2
3.1.1 Names and Functions of Components of the RTEX-compatible GM1 Controller.....	3-2
3.1.2 Names and Functions of Components of the EtherCAT-compatible GM1 Controller.....	3-5
3.1.3 Terminal Layout Diagram of the GM1 Controller (RTEX-compatible / EtherCAT-compatible)	3-7
3.2 Expansion Units	3-11
3.2.1 Names and Functions of Components of the GM1 Digital I/O Unit ..	3-11
3.2.2 Terminal Layout Diagram of the GM1 Digital I/O Unit	3-12
3.2.3 Names and Functions of Components of the GM1 Analog I/O Unit ..	3-15
3.2.4 Terminal Layout Diagram of the GM1 Analog I/O Unit.....	3-16
3.2.5 Names and Functions of Parts of the GM1 Pulse Output Unit.....	3-17
3.2.6 Terminal Layout Diagram of the GM1 Pulse Output Unit	3-18
4 Installation	4-1
4.1 Installation of the GM1 Series.....	4-2
4.1.1 Installation Environment and Space	4-2
4.1.2 Unit Installation Procedure	4-4
4.1.3 Removing the Unit	4-5
4.1.4 Attaching to DIN Rail.....	4-6
4.1.5 Removing from DIN Rail	4-7
5 Wiring	5-1
5.1 Wiring the Power Supply.....	5-2
5.1.1 Common Precautions	5-2
5.1.2 Power Supply for the GM1 Controller (RTEX-compatible / EtherCAT-compatible).....	5-3
5.1.3 Grounding	5-3

5.2	Wiring of Network.....	5-5
5.3	Wiring of Input and Output.....	5-7
5.3.1	Precautions Common to Input and Output.....	5-7
5.3.2	Input Wiring.....	5-7
5.3.3	High-speed Counter Input Wiring.....	5-8
5.3.4	Output Wiring.....	5-10
5.4	Connection Using the Discrete-wire Connector.....	5-11
5.4.1	Specifications of the Discrete-wire Connector.....	5-11
5.4.2	Wiring the Discrete-wire Connector.....	5-12
5.5	Safety Measures.....	5-15
5.5.1	General Safety Measures.....	5-15
5.5.2	Momentary Power Failure.....	5-15
5.5.3	Watchdog Timer.....	5-15
6	Checking Wiring.....	6-1
6.1	Safety Circuit Design.....	6-2
6.2	Items to Check during Wiring.....	6-3
6.3	Power ON Operation.....	6-4
6.4	Power OFF Operation.....	6-5
7	Using the SD Memory Card and SDHC Memory Card.....	7-1
7.1	Preparation of the SD Memory Card and SDHC Memory Card.....	7-2
7.2	Inserting the SD Memory Card and SDHC Memory Card.....	7-3
8	Device Reset.....	8-1
8.1	Device Reset by GM1 Controller Operation.....	8-2
9	Troubleshooting.....	9-1
9.1	Self-diagnostic Function.....	9-2
9.2	Operation Status at the Time of Error.....	9-3
9.3	What to Do If an Error Occurs.....	9-4
9.3.1	ERROR LED Flashes on the Control Unit.....	9-4
9.3.2	ALARM LED Lights on the Control Unit.....	9-4
9.3.3	POWER LED Does not Light on the Control Unit.....	9-5
9.3.4	Desired Output Is Not Obtained: Checking when the Output Does Not Turn ON / OFF.....	9-5
9.3.5	Desired Input Is Not Obtained: Checking when the Input Does Not Turn ON / OFF.....	9-6
9.3.6	If the ALARM LED Is Lit on the Expansion Unit.....	9-6
9.3.7	If the ALARM LED Is Unlit on the Expansion Unit.....	9-7
10	Maintenance and Inspection.....	10-1
10.1	Inspection.....	10-2
11	Specifications and Dimensions.....	11-1
11.1	General Specifications.....	11-2
11.2	Specifications of the GM1 Controller.....	11-4

11.2.1	High-speed Counter Input Specifications of the GM1 Controller....	11-4
11.2.2	Input Specifications of the GM1 Controller.....	11-4
11.2.3	Output Specifications of the GM1 Controller (Sink Type)	11-5
11.2.4	Output Specifications of the GM1 Controller (Source Type)	11-6
11.3	Specifications of Expansion Units	11-8
11.3.1	Input Specifications of the 64-point Digital Input Unit	11-8
11.3.2	Output Specifications of the 64-point Digital Output Unit (Sink Type).....	11-9
11.3.3	Output Specifications of the 64-point Digital Output Unit (Source Type).....	11-11
11.3.4	I/O Specifications of the 64-point Digital I/O Unit (Sink Type).....	11-12
11.3.5	I/O Specifications of the 64-point Digital I/O Unit (Source Type)....	11-15
11.3.6	Input Specifications of the Analog Input Unit	11-18
11.3.7	Output Specifications of the Analog Output Unit.....	11-19
11.3.8	Performance Specifications of the Pulse Output Unit	11-20
11.4	Communication Specifications	11-24
11.4.1	Specifications of the USB Port	11-24
11.4.2	Specifications of the COM Port (RS-232C).....	11-24
11.4.3	Specifications of the LAN Port.....	11-25
11.4.4	Specifications of the RTEX Port.....	11-25
11.4.5	Specifications of the EtherCAT Port	11-26
11.5	Performance Specifications	11-27
11.6	Dimensions	11-28
11.6.1	Dimensions of the GM1 Controller	11-28
11.6.2	Dimensions of the GM1 Expansion Unit.....	11-29
11.7	Conformance to international standards	11-32
11.7.1	List of conformed standards for motion controllers	11-32
11.7.2	About Radio Waves Act(South Korea)	11-32
Appendix Warranty / Cautions for Proper Use		App-1
Warranty		App-2
Warranty Period		App-2
Warranty Scope		App-2
Cautions for Proper Use		App-3

(MEMO)

1 Before Using This Product



1.1 Safety Precautions.....	1-2
1.2 Handling Precautions.....	1-3



1.1 Safety Precautions





1.1 Safety Precautions









This section explains important rules that must be observed to prevent personal injury and property damage.

- Injuries and damages that may occur as a result of incorrect use are classified into the following levels and safety precautions are explained according to the level.

 WARNING	Indicates that there is a risk of death or serious injury
 CAUTION	Indicates that there is a risk of minor injury or property damage





	Indicates an action that is prohibited
	Indicates an action that must be taken

 WARNING	
	<ul style="list-style-type: none"> • Take safety measures outside this product to ensure the safety of the entire system even if this product fails or an error occurs due to external factors.
	<ul style="list-style-type: none"> • Do not use this product in atmospheres that contain flammable gases. Doing so may result in explosion.
	<ul style="list-style-type: none"> • Do not throw this product into the fire. Doing so may cause the batteries or other electronic parts to explode.

 CAUTION	
	<ul style="list-style-type: none"> • To prevent abnormal heat generation or smoke generation, use this product with some leeway from the guaranteed characteristics and performance values of the product.
	<ul style="list-style-type: none"> • Do not disassemble or modify this product. Doing so may result in abnormal heat generation or smoke generation.
	<ul style="list-style-type: none"> • Do not touch any terminals while the power is on. Doing so may result in electrical shock.
	<ul style="list-style-type: none"> • Configure emergency stop and interlock circuits outside this product.
	<ul style="list-style-type: none"> • Connect wires and connectors properly. Failure to do so may result in abnormal heat generation or smoke generation.
	<ul style="list-style-type: none"> • Do not perform work (such as connection or removal) with the power turned on. Doing so may result in electrical shock.
	<ul style="list-style-type: none"> • If this product is used in any way that is not specified by Panasonic, its protection function may be impaired.
	<ul style="list-style-type: none"> • This product has been developed and manufactured for industrial use only.

1.2 Handling Precautions

- In this manual, the following symbols are used to indicate safety information that must be observed.

	Indicates an action that is prohibited or a matter that requires caution.
	Indicates an action that must be taken.
	Indicates supplemental information.
	Indicates details about the subject in question or information useful to remember.
	Indicates operation procedures.

(MEMO)

2 Overview (System Configuration)

2.1 Basic System Configuration.....	2-2
2.1.1 Outline of the GM1 System.....	2-2
2.1.2 Unit Types	2-2
2.1.3 Restrictions on the Number of Expansion Units	2-3
2.2 Restrictions on the GM1 Controller and Servo Amplifiers.....	2-5
2.2.1 Restrictions on the Combination of the GM1 Controller and Servo Amplifiers	2-5
2.2.2 Restrictions on Servo Amplifier Parameters	2-6
2.3 Programming Tools	2-8
2.3.1 Software Usage Environment and Applicable Cables	2-8

2.1 Basic System Configuration

2.1 Basic System Configuration

2.1.1 Outline of the GM1 System

■ Network control

With the RTEX-compatible GM1 Controller, a MINAS series A6N/A5N servomotor network system can be easily configured using the RTEX network dedicated to motion control.

The EtherCAT-compatible GM1 Controller is a MINAS series servomotor network system can be easily configured by adopting EtherCAT communication.

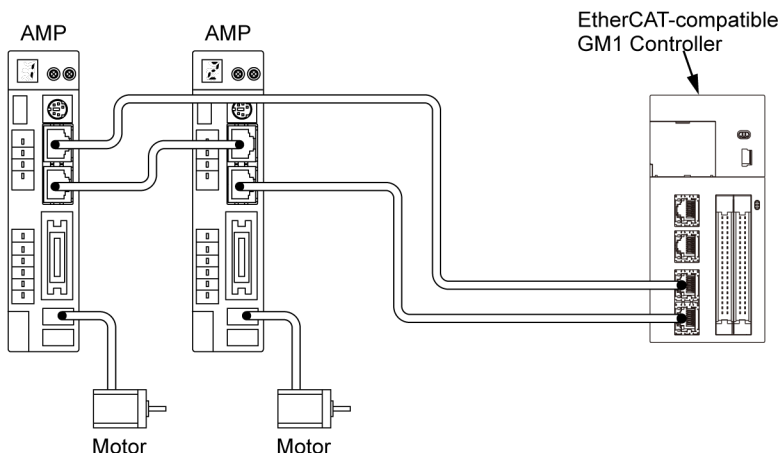

■ Two LAN ports

There are two Ethernet connection ports.

Each port can have a unique IP address. They can be used for different purposes, such as for an in-device network or for a host system network.

■ Equipped with the high-speed counter input and PWM output

The RTEX-compatible GM1 Controller / EtherCAT-compatible GM1 Controller is equipped with a 2-ch high-speed counter input for 16 MHz (multiplied by 4) and a 4-ch PWM output that can output a maximum of 100 kHz. These functions can be used without adding expansion units.

2.1.2 Unit Types

■ Controller

Type	Function	Model number
RTEX-compatible GM1 Controller (Sink type)	RTEX 16-axis motion controller Transistor NPN output type	AGM1CSR16T
EtherCAT-compatible GM1 Controller (Sink type)	EtherCAT motion controller Transistor NPN output type	AGM1CSEC16T

Type	Function	Model number
EtherCAT-compatible GM1 Controller (Source type)	EtherCAT motion controller Transistor PNP output type	AGM1CSEC16P

■ Expansion units

Type	Function	Model number
Digital input (64 points)	24 V DC, 64 input points	AGM1X64D2
Digital output (64 points) (sink type)	64 output points Transistor NPN type	AGM1Y64T
Digital output (64 points) (source type)	64 output points Transistor PNP type	AGM1Y64P
Digital I/O (64 points) (sink type)	24 V DC, 32 input points 32 output points Transistor NPN type	AGM1XY64D2T
Digital I/O (64 points) (source type)	24 V DC, 32 input points 32 output points Transistor PNP type	AGM1XY64D2P
Analog input (8 points)	8 input points	AGM1AD8
Analog output (4 points)	4 output points	AGM1DA4
Pulse output (Transistor output type)	4-axis, pulse train, 500 kpps Open collector output	AGM1PG04T
Pulse output (Line driver output type)	4-axis, pulse train, 4 Mpps Line driver output	AGM1PG04L

2.1.3 Restrictions on the Number of Expansion Units

Up to 15 expansion units can be mounted on the right side of the GM1 Controller (RTEX-compatible / EtherCAT-compatible).

Example: For RTEX-compatible GM1 Controller

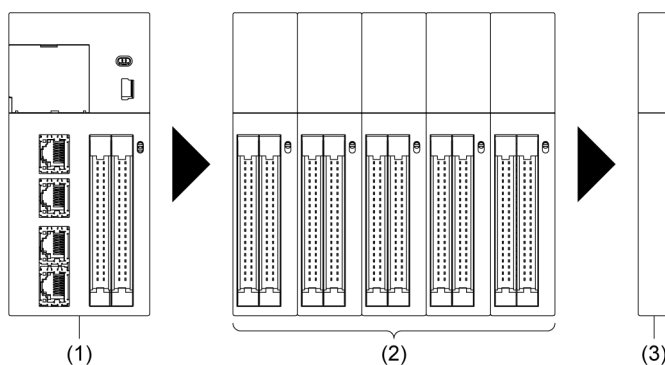

(1)	RTEX-compatible GM1 Controller	(2)	Expansion units	(3)	End unit
-----	--------------------------------	-----	-----------------	-----	----------

2.1 Basic System Configuration



- Make sure to connect an end unit to the end of the system.

2.2 Restrictions on the GM1 Controller and Servo Amplifiers

2.2.1 Restrictions on the Combination of the GM1 Controller and Servo Amplifiers

As for the combination of the GM1 Controller (RTEX-compatible / EtherCAT-compatible) and each MINAS series, confirm the following restrictions.

Combination of the RTEX-compatible GM1 Controller and servo amplifiers

Connectable servo amplifier		Description
A5N	A6N	
•	•	A5N and A6N can be connected to the same network.

Combination of the EtherCAT-compatible GM1 Controller and servo amplifiers

Connectable servo amplifier		Description
A5B	A6B	
•	•	A5B and A6B can be connected to the same network.

Note

- When using servo amplifiers in combination with the GM1 Controller, use the ones with the latest software version

■ Setting ranges of movement amount and speed

The input range of the movement amount or speed specified in the GM1 Controller (RTEX-compatible / EtherCAT-compatible) may differ from the upper and lower setting limits of the servo amplifier.

Info.

- The communication cycle and command update cycle supported by the RTEX-compatible GM1 Controller and servo amplifiers A5N and A6N are as follows.
 - RTEX-compatible GM1 Controller: Communication cycle: 500 μ s to 2 ms, Command update cycle: 500 μ s to 4 ms
 - Servo amplifier A5N: Communication cycle: 500 μ s to 1 ms, Command update cycle: 500 μ s to 1 ms
 - Servo amplifier A6N: Communication cycle: 500 μ s to 2 ms, Command update cycle: 500 μ s to 4 ms
- The control cycles supported by the EtherCAT-compatible GM1 Controller and servo amplifiers A5B or A6B are as follows.
 - EtherCAT-compatible GM1 Controller: Control cycle: 500 μ s to 4 ms
 - Servo amplifier A5B: Control cycle: 500 μ s to 4 ms
 - Servo amplifier A6B: Control cycle: 500 μ s to 4 ms

2.2 Restrictions on the GM1 Controller and Servo Amplifiers

2.2.2 Restrictions on Servo Amplifier Parameters

■ Parameters for servo amplifiers on the A5N/A6N

Some parameters for servo amplifiers on the A5N/A6N side affect the behaviors of the RTEX-compatible GM1 Controller. Use the following parameters.

No.	Name	Settings	Standard factory default setting
Pr5.04	Over-travel inhibit input setup	Use setting value "1 (Disable the over-travel inhibit input)". (Recommended)	1 (Note 1)
Pr7.22	RTEX function extended setup 1	Use setting value "1 (32-byte mode)". (Mandatory)	1 (Note 2)
Pr7.23	RTEX function extended setup 2	<p>Use setting value "18". (Mandatory) This parameter sets each function in bits.</p> <p>bit 0: Allow parameter values to be written via RTEX communication 0: Allow, 1: Disallow</p> <p>bit 1: Set a sub-number for alarm code 0: Fixed at 0, 1: Enable sub-number</p> <p>bit 2: Set RTEX status response conditions when "Over-travel inhibit input setup" is disabled (Pr5.04 = 1) 0: Enable status, 1: Fixed at 0</p> <p>bit 3: Set RTEX status bit assignment for POT and NOT 0: POT corresponds to bit 1 and NOT corresponds to bit 0, 1: NOT corresponds to bit 1 and POT corresponds to bit 0 0: POT corresponds to bit 1 and NOT corresponds to bit 0, 1: NOT corresponds to bit 1 and POT corresponds to bit 0</p> <p>bit 4: Set display mode for "COM" LED 0: Mode 1, 1: Mode 2</p> <p>bit 5: Set non-cyclic command start mode 0: When a change from base command occurs 1: When command code or command argument changes</p> <p>bit 6: Set RTEX status logic for POT and NOT 0: Do not reverse, 1: Reverse</p> <p>bit 7: Set RTEX status logic for PSL and NSL 0: Do not reverse, 1: Reverse</p> <p>bit 8: Select RTEX status from In_Progress / AC_OFF 0: In_Progress, 1: AC_OFF (It is linked to the setting in bit 15.)</p> <p>bit 9: Select whether to return a command error when a command for motion toward the direction of over-travel prohibition is received after deceleration stop is executed by "Over-travel inhibit input setup" 0: Do not return a command error</p>	18 (Note 2)

2.2 Restrictions on the GM1 Controller and Servo Amplifiers

No.	Name	Settings	Standard factory default setting
		1: Return a command error (Bit 10 to bit 13 are not used.) Fix to "0". bit 14: Set position deviation [command unit] output 0: Internal commanded position (after filtering) [command unit] - Actual position [command unit] 1: Internal commanded position (before filtering) [command unit] - Actual position [command unit] Bit 15: Select extended RTEX status from In_Progress / AC_OFF / Pr7.112 settings 0: Follow the setting of Pr7.23 bit 8 (In_Progress / AC_OFF) 1: Follow the setting of Pr7.112.	
Pr7.25	RTEX speed unit setup	Use setting value "1 (command unit/s)". (Mandatory)	1 ^(Note 2)

(Note 1) We recommend that the set value should not be changed judging from the characteristics of the GM1 and MINAS.

(Note 2) Do not change the set value. If the set value is changed, the RTEX-compatible GM1 Controller will make an error stop.

■ Parameters for servo amplifiers on the A5B/A6B

Some parameters for servo amplifiers on the A5B/A6B side affect the behaviors of the EtherCAT-compatible GM1 Controller. Use the following parameters.

No.	Name	Settings	Standard factory default setting
Pr5.04	Over-travel inhibit input setup	Use setting value 1. (Recommended)	1 ^(Note 1)

(Note 1) We recommend that the set value should not be changed judging from the characteristics of the GM1 and MINAS.

2.3 Programming Tools

2.3 Programming Tools

2.3.1 Software Usage Environment and Applicable Cables

Programming software

Product name	Applicable version	Applicable language	Product No.	Remarks
GM Programmer	Ver.1.2 or higher	Japanese / English / Chinese	AGMSMP	

(Note 1) When the GM Programmer is installed, MINAS setup support software "PANATERM Lite for GM" is installed at the same time.

Software operating environment

Item	Description
OS	Microsoft(R) Windows(R) 10: 32 bit / 64 bit
PC	PC with the following installed: <ul style="list-style-type: none"> • Microsoft.NET Framework 4.6.1 or higher • Microsoft Visual C++ 2010 SP1 Redistributable Package (x86) • Microsoft Visual C++ 2010 SP1 Redistributable Package (x64) • Microsoft Visual C++ 2013 Redistributable Package (x86) • Microsoft Visual C++ 2013 Redistributable Package (x64) • Microsoft Visual C++ 2015 Update 3 Redistributable Package (x86) • Microsoft Visual C++ 2015 Update 3 Redistributable Package (x64)
HDD	At least 4 GB of free space
Memory	At least 8 GB
Communication port	LAN port (for Ethernet connection) USB 2.0 port (for USB connection)

PC connection cable

- Use a commercial USB cable.

Cable type	Length
USB 2.0 cable (A: miniB) ^(Note 1)	Max. 5 m

(Note 1) Match the connection terminal shape of the USB2.0 cable on the PC side with the specifications of the PC side.

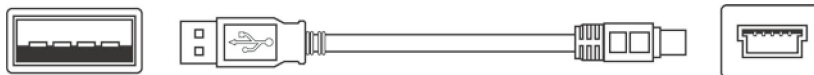

USB A type (male) - USB miniB type (5-pin, male)
(PC side) (GM1 side)

i Info.

For the tool operation, refer to the , *GM1 Controller RTEX User's Manual (Operation)* or *GM1 Controller EtherCAT User's Manual (Operation)*.

3 Names and Functions of Components

3.1 Names and Functions of Components of the GM1 Controller	3-2
3.1.1 Names and Functions of Components of the RTEX-compatible GM1 Controller.....	3-2
3.1.2 Names and Functions of Components of the EtherCAT-compatible GM1 Controller.....	3-5
3.1.3 Terminal Layout Diagram of the GM1 Controller (RTEX-compatible / EtherCAT-compatible)	3-7
3.2 Expansion Units	3-11
3.2.1 Names and Functions of Components of the GM1 Digital I/O Unit .	3-11
3.2.2 Terminal Layout Diagram of the GM1 Digital I/O Unit	3-12
3.2.3 Names and Functions of Components of the GM1 Analog I/O Unit	3-15
3.2.4 Terminal Layout Diagram of the GM1 Analog I/O Unit.....	3-16
3.2.5 Names and Functions of Parts of the GM1 Pulse Output Unit.....	3-17
3.2.6 Terminal Layout Diagram of the GM1 Pulse Output Unit	3-18

3.1 Names and Functions of Components of the GM1 Controller

3.1 Names and Functions of Components of the GM1 Controller

3.1.1 Names and Functions of Components of the RTEX-compatible GM1 Controller

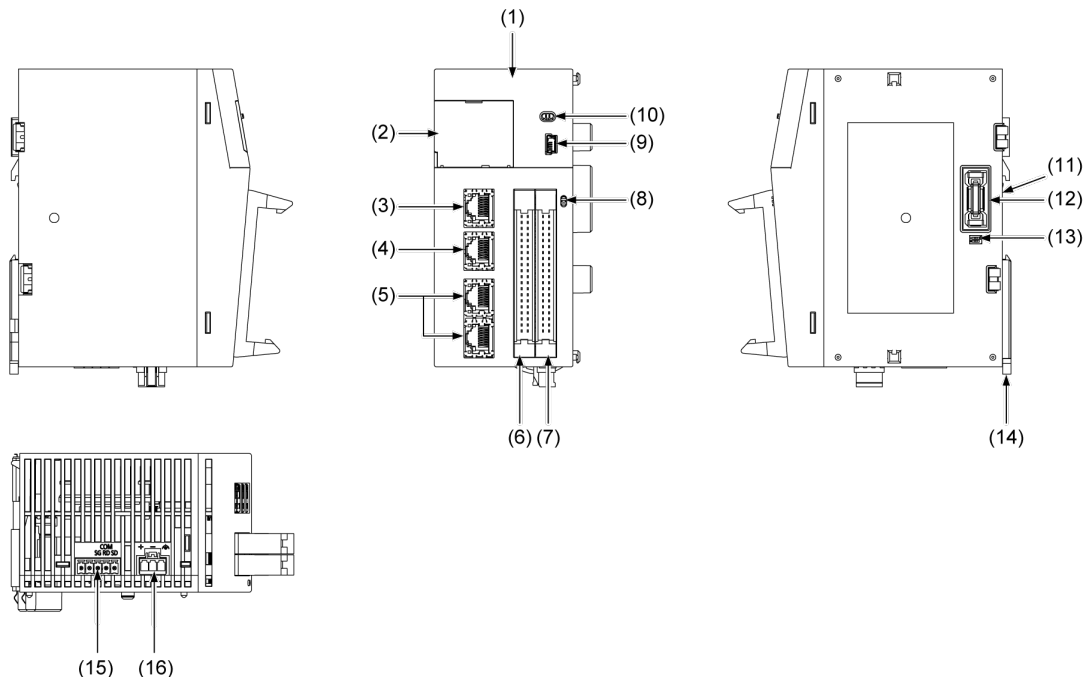

No.	Name	Function
(1)	Operation monitor LEDs	LEDs indicate the RTEX-compatible GM1 Controller state. Refer to " Names and functions of operation monitor LEDs ".
(2)	Card cover Inside the card cover ^(Note 1)	Stores the SD memory card. The following are contained inside the cover. (2) -1 SD memory card slot (2) -2 Cover switch
(3)	LAN port 1	Ethernet connector
(4)	LAN port 2	Ethernet connector
(5)	RTEX port	Motion network connector dedicated for connecting the MINAS A6N or A5N series <ul style="list-style-type: none"> • "RX" reception side • "TX" transmission side
(6)	High-speed counter input connector	Refer to " High-speed counter input part ".

3.1 Names and Functions of Components of the GM1 Controller

No.	Name	Function
(7)	General-purpose I/O connector	Refer to "General-purpose I/O part".
(8)	Display selector switch	Used to select either the input state (X) or the output state (Y) of operation monitor LEDs
(9)	USB port	Used to connect to a personal computer that uses a tool software. (miniB type)
(10)	Mode selector switch	Used to change the mode to RUN or STOP. Regardless of whether the switch is set to RUN or STOP, the mode can be switched through remote operation from the GM Programmer. When power is turned ON, it operates in the mode set on the switch.
(11)	DIN rail attachment part	This is the part which is attached to the DIN rail.
(12)	Unit connector	This is a connector to which each expansion unit is connected. An end unit is fitted when the unit is shipped.
(13)	Dip switches 	SW1: Do not change the setting. It is set to ON as the factory default. SW2: Reset bit This is the switch used to reset the devices. If the power supply is turned ON with the mode selector switch set to STOP and the reset bit set to ON, the "Device reset (GM1 initialization)" function is implemented. (Note 2)
(14)	DIN hook	Used to fix the Controller to a DIN rail
(15)	COM port terminal	Serial (RS-232C) connector
(16)	Power supply connector	24 V DC power supply connector

(Note 1) Do not apply an excessive force to the card cover when opening or closing it or when the cover is left open.

Otherwise, the cover attachment part will be deformed to cause malfunction in the cover switch mounted inside the product.

(Note 2) For details on the device reset function, refer to "8.1 Device Reset by GM1 Controller Operation".

■ Names and functions of operation monitor LEDs

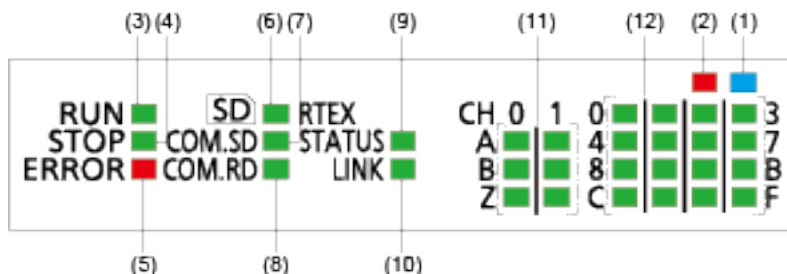

No.	Name	LED color	Function
(1)	Power	Blue	Indicates the power state of the unit. Lit: Power supply of the unit is started normally. Unlit: Power is not supplied. Or, there is an error in the power supply to the system.
(2)	Alarm	Red	Indicates that an alarm has occurred in the system. Lit: System error

3.1 Names and Functions of Components of the GM1 Controller

No.	Name	LED color	Function
			Unlit: Normal
(3)	RUN	Green	Indicates the operating state of the application.
(4)	STOP	Green	RUN (Lit) and STOP (Unlit): The application is in the operating state. RUN (Unlit) and STOP (Lit): The application is in the stopped state. RUN (Unlit) and STOP (Unlit): No application exists.
(5)	ERROR	Red	Indicates that an error has occurred in the system. Flashing: An error occurred. (Flashing cycle: ON for 0.5 s and OFF for 0.5 s) Unlit: Normal
(6)	SD	Green	Indicates an access state to the SD memory card. Lit: Currently accessing to the SD memory card Unlit: No access to the SD memory card
(7)	COM.SD	Green	Flashes while data is transmitted from the COM port.
(8)	COM.RD	Green	Flashes while data is received by the COM port.
(9)	RTEX STATUS	Green	Indicates the packet transmission / reception state through motion communication. Lit: Communication is established with normal communication. Flashing: Starting up Unlit: Communication is not established.
(10)	RTEX LINK	Green	Indicates the LINK state of motion communication. Lit: Normal connection (The TX of the sending node and the RX of the local node are electrically connected normally.) Unlit: Not connected
(11)	CH0 A, B, and Z CH1 A, B, and Z	Green	Indicates the status of the high-speed counter input signal ^(Note 1)
(12)	0-F	Green	Indicates the ON/OFF state of the Controller I/O depending on the state of the display selector switch. Display selector switch X Lit: Each terminal of the input contacts X0-XF is ON. Unlit: Each terminal of the input contacts X0-XF is OFF. Display selector switch Y Lit: Each terminal of the output contacts Y0-YF is ON. Unlit: Each terminal of the output contacts Y0-YF is OFF.

(Note 1) The LEDs for the high-speed counter input signal flash according to the input statuses. Thus look as if they are continuously lit if the input frequencies are high.

3.1 Names and Functions of Components of the GM1 Controller

3.1.2 Names and Functions of Components of the EtherCAT-compatible GM1 Controller

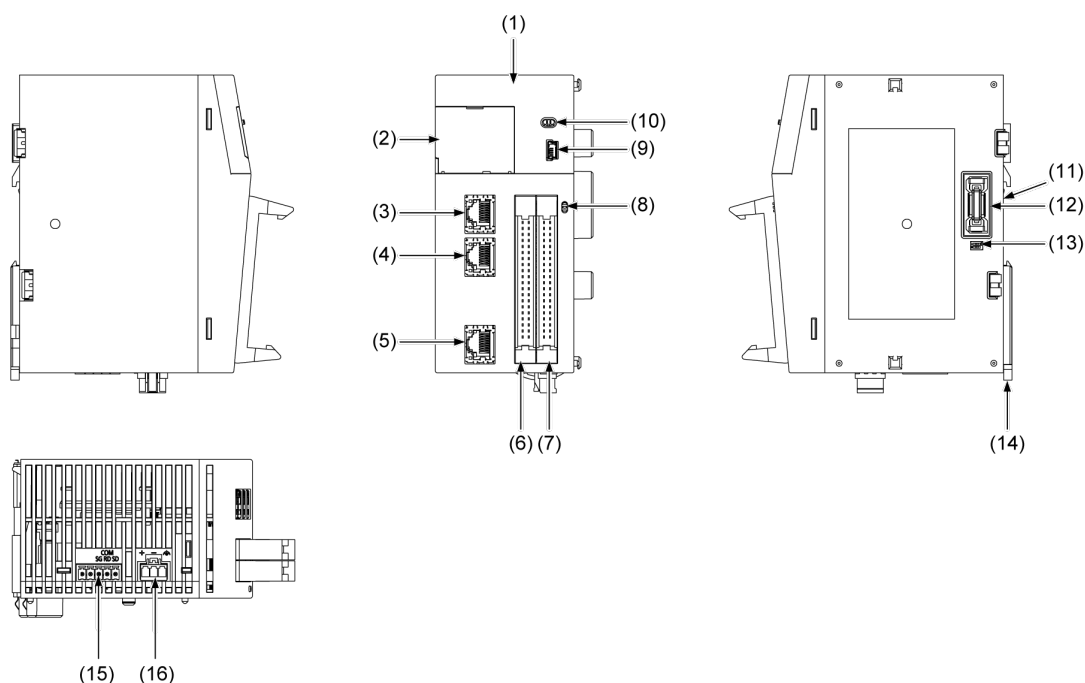

No.	Name	Function
(1)	Operation monitor LEDs	LEDs indicate the EtherCAT-compatible GM1 Controller state. Refer to "Names and functions of operation monitor LEDs".
(2)	Card cover Inside the card cover ^(Note 1)	Stores the SD memory card. The following are contained inside the cover. (2) -1 SD memory card slot (2) -2 Cover switch
(3)	LAN port 1	Ethernet connector
(4)	LAN port 2	Ethernet connector
(5)	EtherCAT port	Motion network connector dedicated for connecting the MINAS A6B or A5B series
(6)	High-speed counter input connector	Refer to "High-speed counter input part".
(7)	General-purpose I/O connector	Refer to "General-purpose I/O part".
(8)	Display selector switch	Used to select either the input state (X) or the output state (Y) of operation monitor LEDs
(9)	USB port	Used to connect to a personal computer that uses a tool software. (miniB type)

3.1 Names and Functions of Components of the GM1 Controller

No.	Name	Function
(10)	Mode selector switch	Used to change the mode to RUN or STOP. Regardless of whether the switch is set to RUN or STOP, the mode can be switched through remote operation from the GM Programmer. When power is turned ON, it operates in the mode set on the switch.
(11)	DIN rail attachment part	This is the part which is attached to the DIN rail.
(12)	Unit connector	This is a connector to which each expansion unit is connected. An end unit is fitted when the unit is shipped.
(13)	Dip switches 	SW1: Do not change the setting. It is set to ON as the factory default. SW2: Reset bit This is the switch used to reset the devices. If the power supply is turned ON with the mode selector switch set to STOP and the reset bit set to ON, the "Device reset (GM1 initialization)" function is implemented. (Note 2)
(14)	DIN hook	Used to fix the Controller to a DIN rail
(15)	COM port terminal	Serial (RS-232C) connector
(16)	Power supply connector	24 V DC power supply connector

(Note 1) Do not apply an excessive force to the card cover when opening or closing it or when the cover is left open.

Otherwise, the cover attachment part will be deformed to cause malfunction in the cover switch mounted inside the product.

(Note 2) For details on the device reset function, refer to "8.1 Device Reset by GM1 Controller Operation".

■ Names and functions of operation monitor LEDs

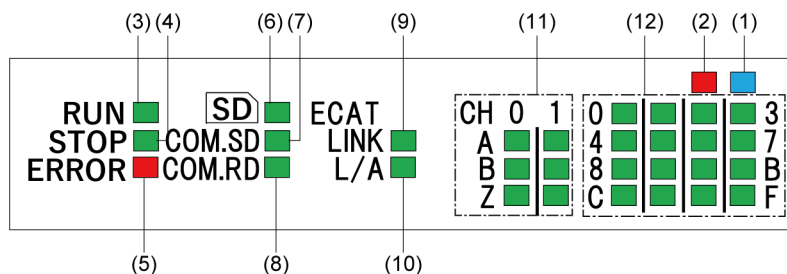

No.	Name	LED color	Function
(1)	Power	Blue	Indicates the power state of the unit. Lit: Power supply of the unit is started normally. Unlit: Power is not supplied. Or, there is an error in the power supply to the system.
(2)	Alarm	Red	Indicates that an alarm has occurred in the system. Lit: System error Unlit: Normal
(3)	RUN	Green	Indicates the operating state of the application. RUN (Lit) and STOP (Unlit): The application is in the operating state. RUN (Unlit) and STOP (Lit): The application is in the stopped state. RUN (Unlit) and STOP (Unlit): No application exists.
(4)	STOP	Green	

3.1 Names and Functions of Components of the GM1 Controller

No.	Name	LED color	Function
(5)	ERROR	Red	Indicates that an error has occurred in the system. Flashing: An error occurred. (Flashing cycle: ON for 0.5 sec and OFF for 0.5 sec) Unlit: Normal
(6)	SD	Green	Indicates an access state to the SD memory card. Lit: Currently accessing to the SD memory card Unlit: No access to the SD memory card
(7)	COM.SD	Green	Flashes while data is transmitted from the COM port.
(8)	COM.RD	Green	Flashes while data is received by the COM port.
(9)	ECAT LINK	Green	Indicates the LINK state of EtherCAT communication. Lit: EtherCAT communication LINK is established. (= Operational mode) (All slave devices connected to the master device are in the Active state.) Flashing: EtherCAT is starting up. (When the Active state turns OFF due to wire disconnection or other reasons while the master device is in the Active state) Unlit: EtherCAT communication is not established. (When the master device is invalid or does not exist)
(10)	ECAT L/A	Green	Indicates the state of the physical port of EtherCAT communication. Lit: PHY LINK is established and data are transmitted / received. Flashing: PHY LINK is established and data are not transmitted / received. Unlit: PHY LINK is not established.
(11)	CH0 A, B, and Z CH1 A, B, and Z	Green	Indicates the status of the high-speed counter input signal ^(Note 1)
(12)	0-F	Green	Indicates the ON/OFF state of the Controller I/O depending on the state of the display selector switch. Display selector switch X Lit: Each terminal of the input contacts X0-XF is ON. Unlit: Each terminal of the input contacts X0-XF is OFF. Display selector switch Y Lit: Each terminal of the output contacts Y0-YF is ON. Unlit: Each terminal of the output contacts Y0-YF is OFF.

(Note 1) The LEDs for the high-speed counter input signal flash according to the input statuses. Thus look as if they are continuously lit if the input frequencies are high.

3.1.3 Terminal Layout Diagram of the GM1 Controller (RTEX-compatible / EtherCAT-compatible)

■ High-speed counter input part

The 2-ch high-speed counter can be used.

3.1 Names and Functions of Components of the GM1 Controller

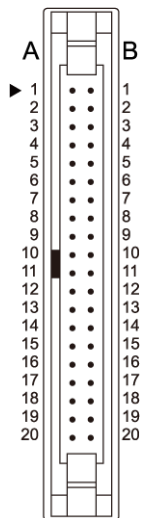

High-speed counter input terminal arrangement

Pin No.		Circuit	Signal name
Ch0	Ch1		
A1	A11		Input A: 24 V DC (12 to 24 V DC)
A2	A12		Input A: 5 V DC (3.5 to 5 V DC)
B1	B11		Input A: COM
B2	B12		Input A: COM
A3	A13		Input B: 24 V DC (12 to 24 V DC)
A4	A14		Input B: 5 V DC (3.5 to 5 V DC)
B3	B13		Input B: COM
B4	B14		Input B: COM
A5	A15		Input Z: 24 V DC (12 to 24 V DC)
A6	A16		Input Z: 5 V DC (3.5 to 5 V DC)
B5	B15		Input Z: COM
B6	B16		Input Z: COM
A7 to A10	B7 to B10	-	-
A17 to A20	B17 to B20	-	-

Info.

For the counter input signals (A, B, and Z), use shielded twisted-pair cables.

■ General-purpose I/O part

High-speed counter control signals (control signals, external outputs) and PWM outputs can be allocated to general-purpose I/O (16 input points, 16 output points).

3.1 Names and Functions of Components of the GM1 Controller

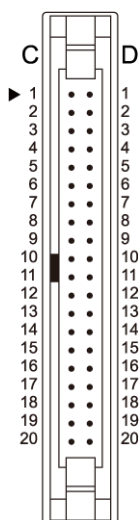

Terminal layout

Pin No. Column C	General-purpose I/O	Signal name
C1	X0	High-speed counter ch0 control 0 signal
C2	X1	High-speed counter ch0 control 1 signal
C3	X2	High-speed counter ch1 control 0 signal
C4	X3	High-speed counter ch1 control 1 signal
C5	X4	-
C6	X5	-
C7	X6	-
C8	X7	-
C9	COM ^(Note 1)	COM
C10	COM ^(Note 1)	COM
C11	Y0	High-speed counter ch0 external output 0 signal
C12	Y1	High-speed counter ch0 external output 1 signal
C13	Y2	High-speed counter ch1 external output 0 signal
C14	Y3	High-speed counter ch1 external output 1 signal
C15	Y4	PWM output 0
C16	Y5	PWM output 1
C17	Y6	PWM output 2
C18	Y7	PWM output 3
C19	+ ^(Note 2)	+V
C20	- ^(Note 3)	-V
D1	X8	-
D2	X9	-

3.1 Names and Functions of Components of the GM1 Controller

Pin No. Column C	General-purpose I/O	Signal name
D3	X10	-
D4	X11	-
D5	X12	-
D6	X13	-
D7	X14	-
D8	X15	-
D9	COM ^(Note 1)	COM
D10	COM ^(Note 1)	COM
D11	Y8	-
D12	Y9	-
D13	Y10	-
D14	Y11	-
D15	Y12	-
D16	Y13	-
D17	Y14	-
D18	Y15	-
D19	+ ^(Note 2)	+V
D20	- ^(Note 3)	-V

(Note 1) The COM terminals (4 places) of the general-purpose input are connected within the unit.

(Note 2) The positive terminals (2 places) of the general-purpose output are connected within the unit.

(Note 3) The negative terminals (2 places) of the general-purpose output are connected within the unit.

3.2 Expansion Units

3.2.1 Names and Functions of Components of the GM1 Digital I/O Unit

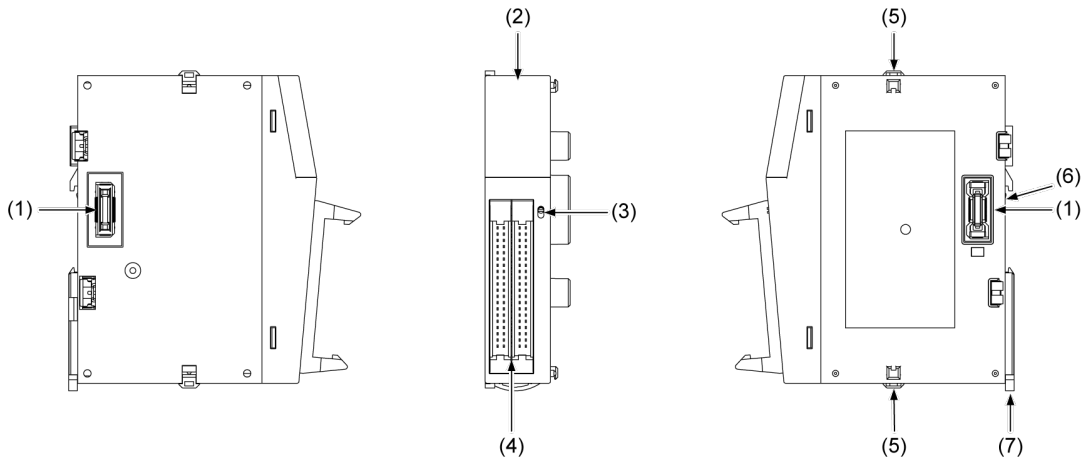

No.	Name	Function
(1)	Unit connector	This is a connector to which each expansion unit is connected.
(2)	Operation monitor LEDs	These LEDs indicate the status of expansion units.
(3)	Display selector switch	This is a switch used to select I/O information to be displayed on LEDs.
(4)	I/O connector	Used to connect input devices to output devices.
(5)	Expansion hook	This is a hook used to fix each expansion unit to another.
(6)	DIN rail attachment part	This is the part which is attached to the DIN rail.
(7)	DIN hook	Used to fix the Controller to a DIN rail

■ Names and functions of each operation monitor LED

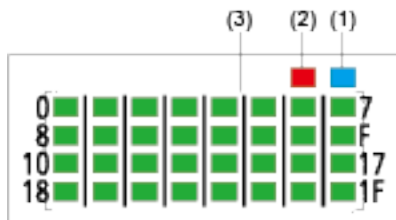

No.	Name	LED color	Function
(1)	Power	Blue	Indicates the power state of the unit. Lit: Power supply of the unit is started normally. Unlit: Power is not supplied. Or, there is an error in the power supply to the system.
(2)	Alarm	Red	Indicates that an alarm has occurred in the unit. Lit: Unit error

3.2 Expansion Units

No.	Name	LED color	Function
			Unlit: Normal
(3)	0-1F	Green	<p>Indicates the ON / OFF state of the expansion unit depending on the state of the display selector switch.</p> <ul style="list-style-type: none"> 64-point digital input unit <ul style="list-style-type: none"> Display selector switch CN1 Lit: Each terminal of the X0-1F is ON. Unlit: Each terminal of the X0-1F is OFF. Display selector switch CN2 Lit: Each terminal of the X20-3F is ON. Unlit: Each terminal of the X20-3F is OFF. 64-point digital output unit <ul style="list-style-type: none"> Display selector switch CN1 Lit: Each terminal of the Y0-1F is ON. Unlit: Each terminal of the Y0-1F is OFF. Display selector switch CN2 Lit: Each terminal of the Y20-3F is ON. Unlit: Each terminal of the Y20-3F is OFF. 64-point digital I/O unit <ul style="list-style-type: none"> Display selector switch CN1 Lit: Each terminal of the X0-1F is ON. Unlit: Each terminal of the X0-1F is OFF. Display selector switch CN2 Lit: Each terminal of the Y0-1F is ON. Unlit: Each terminal of the Y0-1F is OFF.

3.2.2 Terminal Layout Diagram of the GM1 Digital I/O Unit

Terminal layout diagram of the 64-point digital input unit

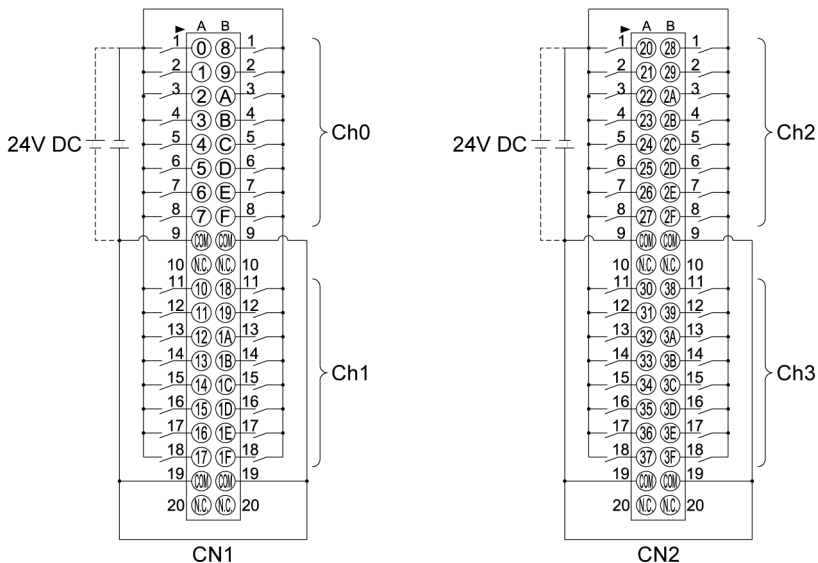

Terminal layout diagram of the 64-point digital output unit (sink type)

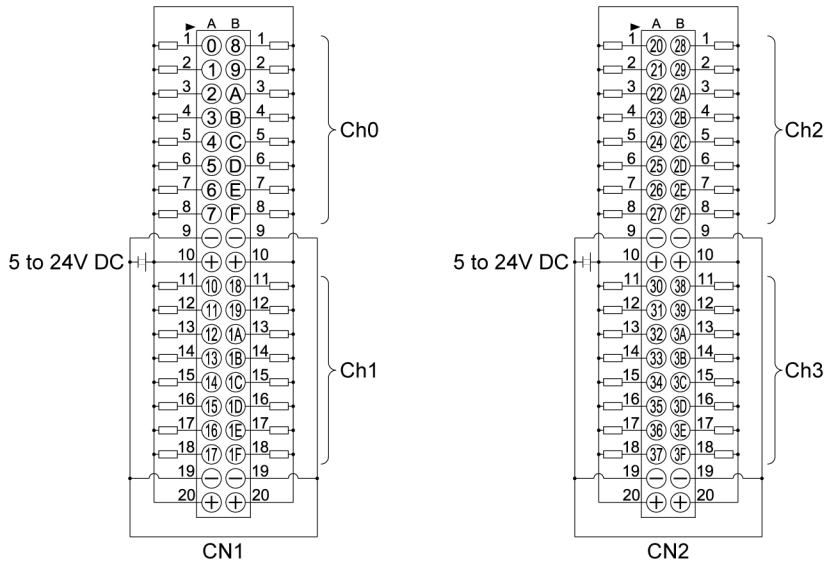

Terminal layout diagram of the 64-point digital output unit (source type)

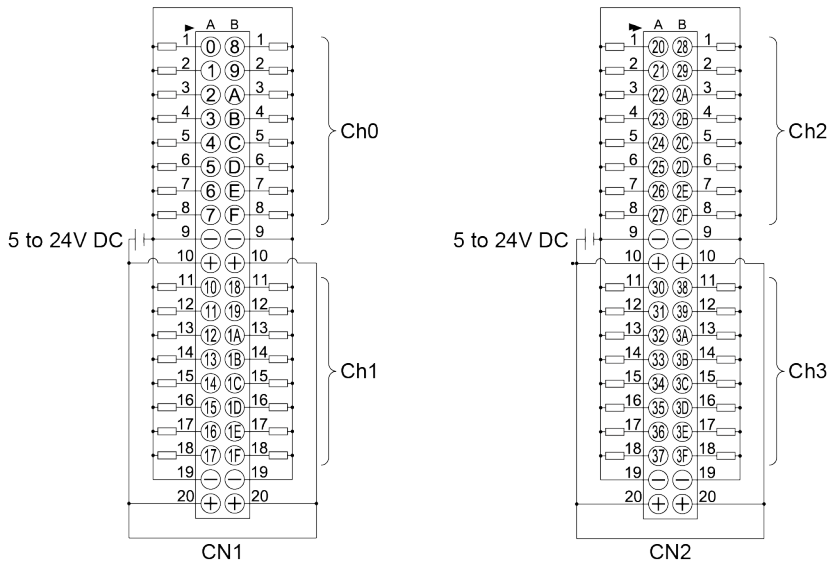

(Note 1) The COM terminals in the same connector are connected internally.

(Note 2) Although the positive and negative terminals are connected internally, connect these terminals externally as well.

3.2 Expansion Units

Terminal layout diagram of the 64-point digital I/O unit (sink type)

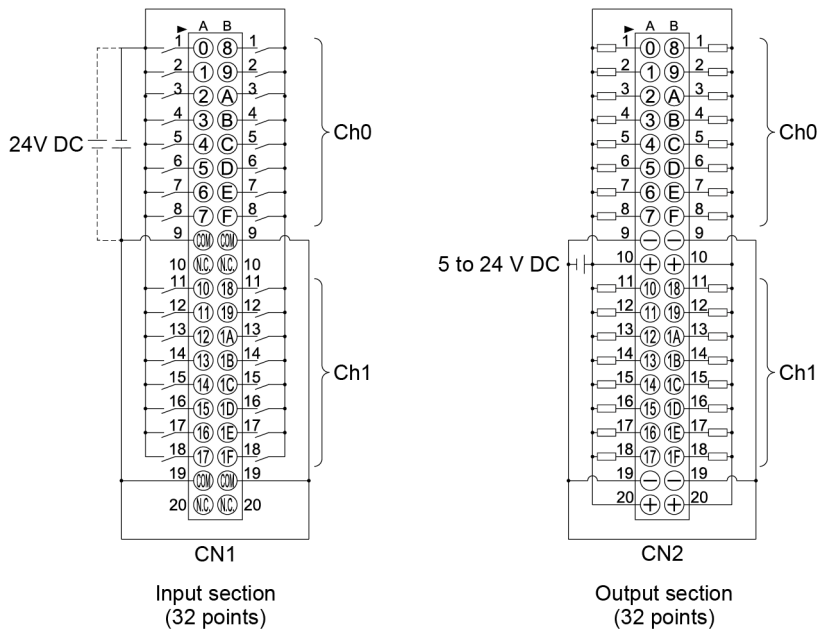

Terminal layout diagram of the 64-point digital I/O unit (source type)

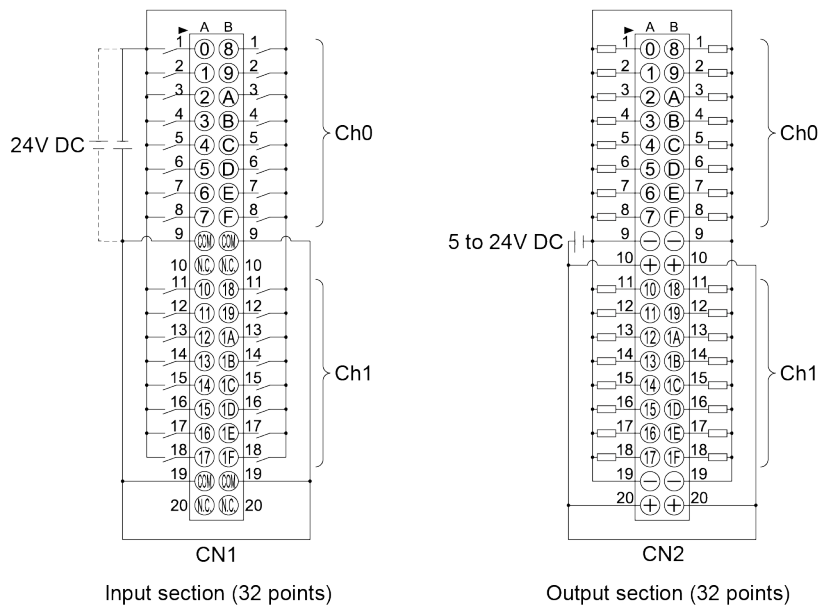

3.2.3 Names and Functions of Components of the GM1 Analog I/O Unit

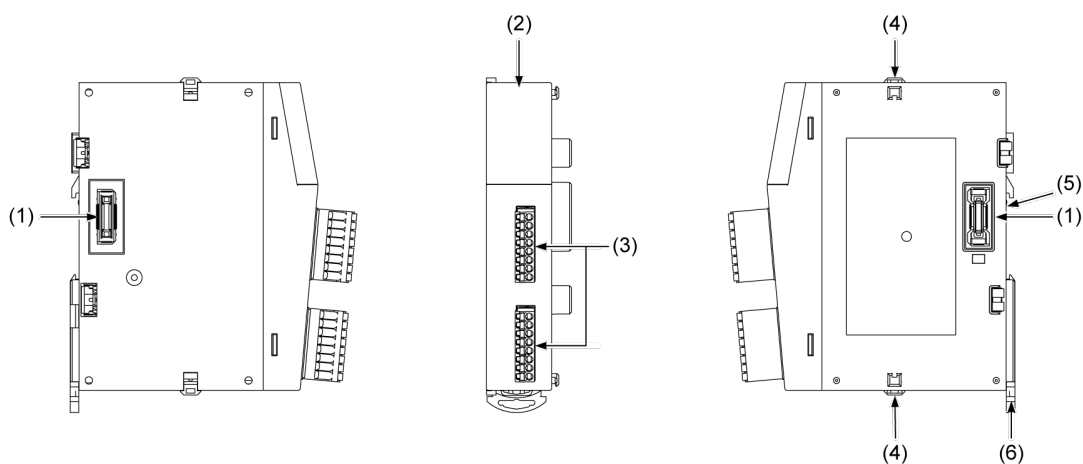

No.	Name	Function
(1)	Unit connector	This is a connector to which each expansion unit is connected.
(2)	Operation monitor LEDs	These LEDs indicate the status of expansion units.
(3)	I/O connector	Used to connect input devices or output devices.
(4)	Expansion hook	This is a hook used to fix each expansion unit to another.
(5)	DIN rail attachment part	This is the part which is attached to the DIN rail.
(6)	DIN hook	Used to fix the Controller to a DIN rail

■ Names and functions of each operation monitor LED

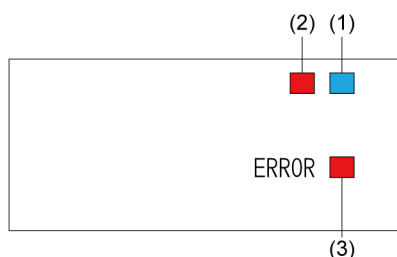

No.	Name	LED color	Function
(1)	Power	Blue	Indicates the completion of power processing of the unit. Lit: Power supply of the unit is started normally. Unlit: Power is not supplied. Or, there is an error in the power supply to the system.
(2)	Alarm	Red	Indicates that an alarm has occurred in the unit. Lit: Unit error Unlit: Normal
(3)	ERROR	Red	Indicates that an error has occurred in the unit. Lit: Error occurred. Unlit: Normal

3.2 Expansion Units

3.2.4 Terminal Layout Diagram of the GM1 Analog I/O Unit

Terminal layout diagram of the Analog Input Unit

The terminal used by the analog voltage input is common to that used by the analog current input.

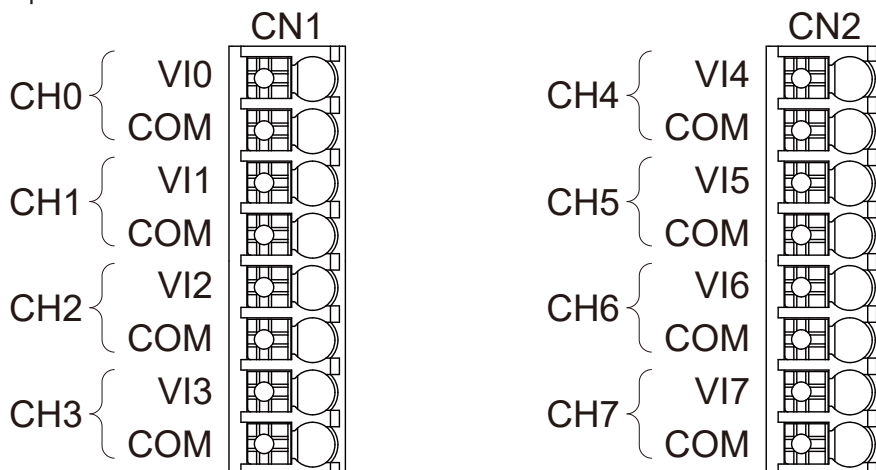

(Note 1) All COM terminals are connected within the unit.

Terminal layout diagram of the Analog Output Unit

The terminal used by the analog voltage output is different from that used by the analog current output.

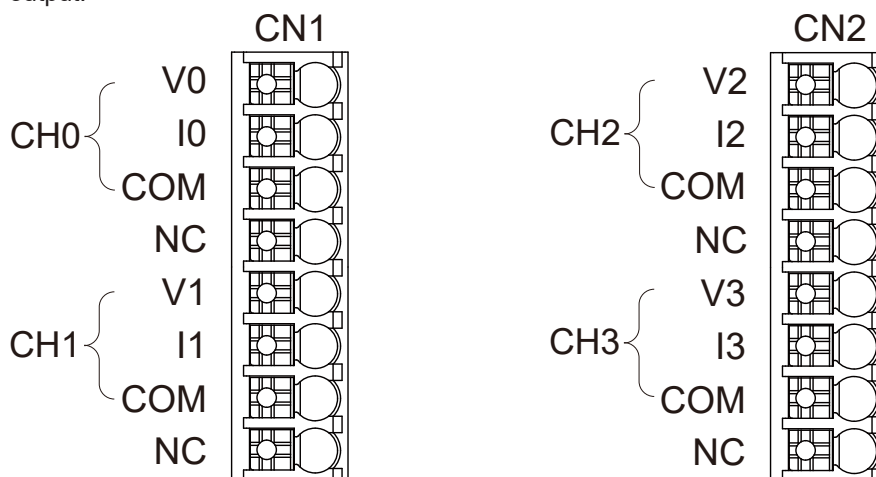

(Note 1) All COM terminals are connected within the unit.

3.2.5 Names and Functions of Parts of the GM1 Pulse Output Unit

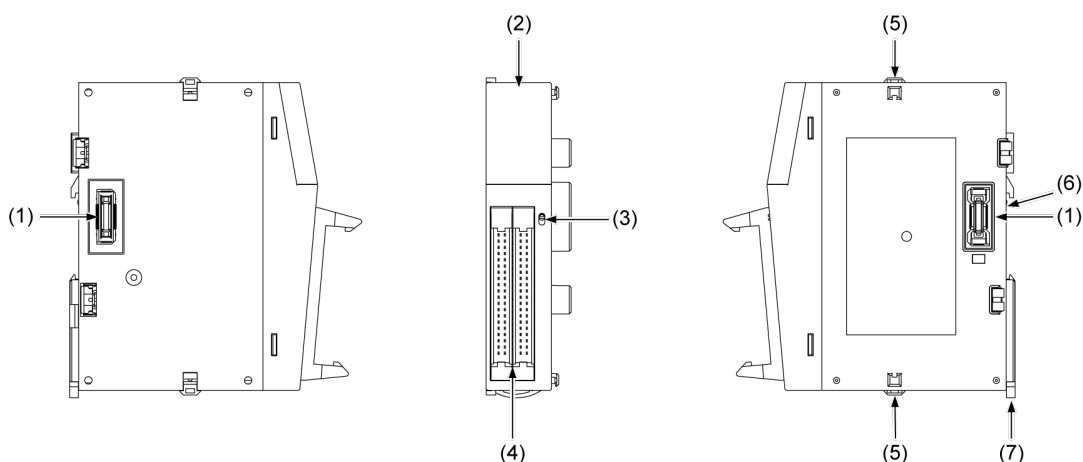

No.	Name	Function
(1)	Unit connector	This is a connector to which each expansion unit is connected.
(2)	Operation monitor LEDs	These LEDs indicate the status of expansion units.
(3)	Operation monitor selection switch	This switches operation display between the display for axes 1 and 2, and that for axes 3 and 4.
(4)	Output connector	This is used to connect an output device.
(5)	Expansion hook	This is a hook used to fix each expansion unit to another.
(6)	DIN rail attachment part	This is the part which is attached to the DIN rail.
(7)	DIN hook	Used to fix the Controller to a DIN rail

■ Names and functions of each operation monitor LED

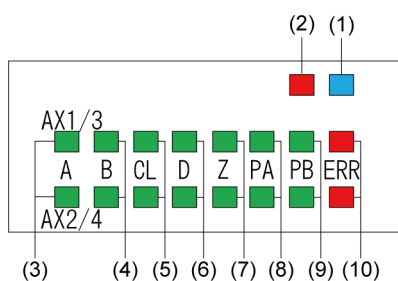

No.	Name	LED color	Function
(1)	Power	Blue	Indicates the completion of power processing of the unit. Lit: Power supply of the unit is started normally. Unlit: Power is not supplied. Or, there is an error in the power supply to the system.
(2)	Alarm	Red	Indicates that an alarm has occurred in the unit. Lit: Unit error Unlit: Normal
(3)	A	Green	Indicates the pulse output A signal. <i>(Note 1)</i>

3.2 Expansion Units

No.	Name	LED color	Function
			<ul style="list-style-type: none"> When set to pulse / sign output method Flashing: During pulse output Unlit: During stop When set to CW / CCW output method Flashing: During pulse output (Forward) Unlit: During stop (Forward)
(4)	B	Green	Indicates the pulse output B signal. ^(Note 1) <ul style="list-style-type: none"> When set to pulse / sign output method Lit: Reverse direction command Unlit: Forward direction command When set to CW / CCW output method Flashing: During pulse output (Reverse) Unlit: During stop (Reverse)
(5)	CL	Green	Indicates the counter clear signal output. Lit: Output ON Unlit: Output OFF
(6)	D	Green	Indicates the near home status. ^(Note 2) Lit: ON Unlit: OFF
(7)	Z	Green	Indicates the home input state. ^(Note 2) Lit: ON Unlit: OFF
(8)	PA	Green	Indicates the pulse input A signal. ^(Note 3)
(9)	PB	Green	Indicates the pulse input B signal. ^(Note 3)
(10)	ERR	Red	Indicates that an error has occurred in the unit. Lit: Error occurred. Unlit: Normal

(Note 1) The pulse output signal display LEDs (A and B) blink at the output frequency (speed). For this reason they may appear to light steadily at high-speed output.

(Note 2) The near home (D) and home input (Z) LEDs light when the respective input becomes valid.

(Note 3) Pulse input signal (PA) and (PB) display the pulse signal input status.

3.2.6 Terminal Layout Diagram of the GM1 Pulse Output Unit

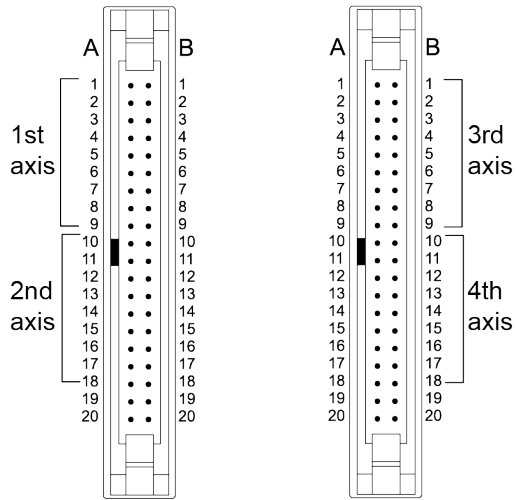

(MEMO)

4 Installation

4.1 Installation of the GM1 Series.....	4-2
4.1.1 Installation Environment and Space	4-2
4.1.2 Unit Installation Procedure	4-4
4.1.3 Removing the Unit	4-5
4.1.4 Attaching to DIN Rail.....	4-6
4.1.5 Removing from DIN Rail	4-7

4.1 Installation of the GM1 Series

4.1 Installation of the GM1 Series

4.1.1 Installation Environment and Space

■ Installation environment

Use the unit within the range of the general specifications when installing.

- Ambient temperature: 0 to +55°C
- Ambient humidity: 10 to 95% RH (at 25°C, non-condensing)
- Pollution degree: 2
- Altitude: 2,000 m above sea level or lower
- Overvoltage category: II or less
- Installation place: It is assumed to be used in an environment inside a control panel (metal panel with sufficient strength) that provides a protection rating of IP54 or higher.

Do not use it in the following environments.

- Direct sunlight
- Sudden temperature changes causing condensation.
- Inflammable or corrosive gas.
- Excessive airborne dust, metal particles or saline matter.
- Benzine, paint thinner, alcohol or other organic solvents or strong alkaline solutions such as ammonia or caustic soda.
- Direct vibration, shock or direct drop of water.
- Influence from power transmission lines, high voltage equipment, power cables, power equipment, radio transmitters, or any other equipment that would generate high switching surges. (100 mm or more)

■ Handling instructions

- Do not directly touch connector pins directly to prevent electrostatic discharge failure.
- Always rid yourself of any static electricity before handling this product.
- Do not connect a unit other than our GM1 series to the side connector on the unit.
- Use copper wires with a temperature rating of 80°C.

■ Measures regarding heat radiation

- As countermeasures against heat radiation, install the unit in the direction shown below.

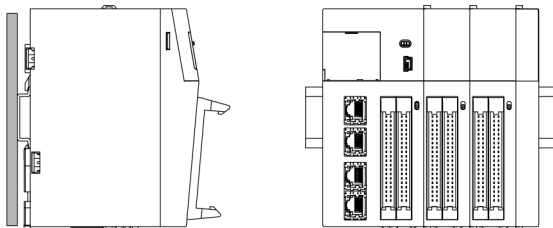

- Do not install the unit stacked up, horizontally or upside down. Doing so will prevent proper cooling of the unit and cause overheating inside.

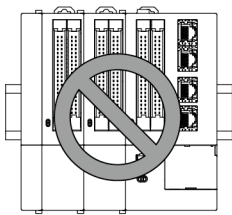

Installing the unit upside down

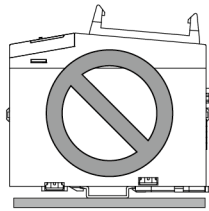

Installing the unit so that it stays in a horizontal position

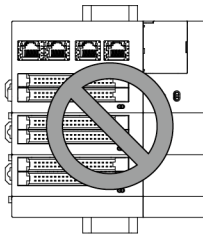

Installing the unit so that the DIN rail is mounted vertically

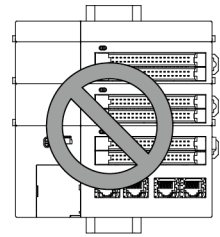

- Do not install the unit above devices which generate heat such as heaters, transformers or large scale resistors.

■ Installation space

- Install the unit at least 50 mm away from other devices or wiring duct on the left and right sides and top and bottom sides of the unit to provide a ventilation space.

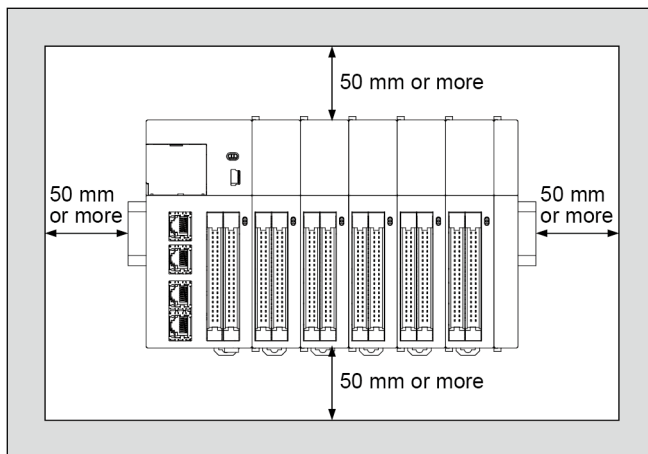

- Do not install the unit above devices which generate heat such as heaters, transformers or large scale resistors.
- In order to eliminate any effects from noise emission, power wires and electromagnetic devices should be kept at least 100 mm away from the surfaces of the unit. When installing the unit behind the doors of the control board, be especially careful to secure clearances as above.

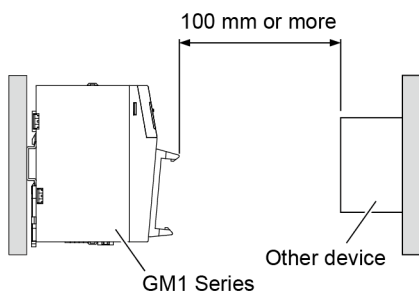

- Secure a clearance of at least 170 mm from the mounting surface of the GM1 Series for connecting tool software cables.

4.1 Installation of the GM1 Series

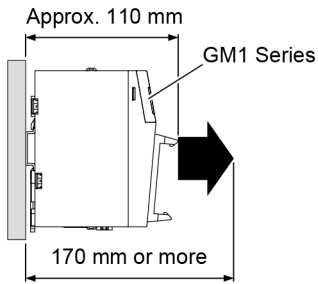

4.1.2 Unit Installation Procedure



- Install the expansion unit between the GM1 Controller (RTEX-compatible / EtherCAT-compatible) and the end unit.
- Make sure to connect an end unit.
- Make sure to turn OFF the power supply before installing the unit.
- Do not directly touch the connector part of the unit.
- Make sure that the connector parts are not stressed when and after installing the unit.

1 2 Procedure

1. Raise the expansion hooks on the sides of the unit with a screwdriver to release them.

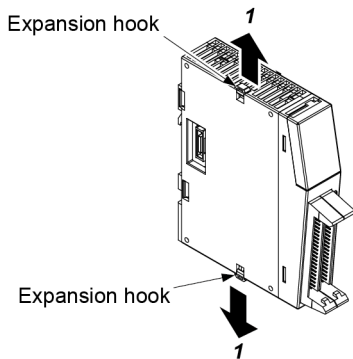

2. Attach the unit connectors on the side of the unit to those on the other unit.

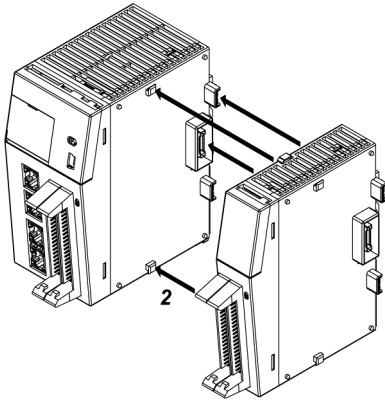

3. Lower the expansion hooks to lock the units in place.

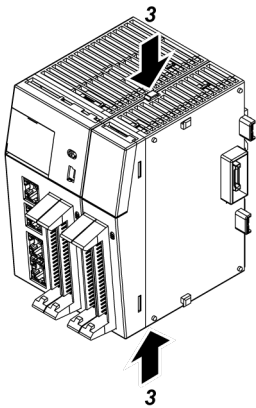

4.1.3 Removing the Unit

1 2 Procedure

1. Raise expansion hooks on the sides of the unit with a screwdriver to release them.

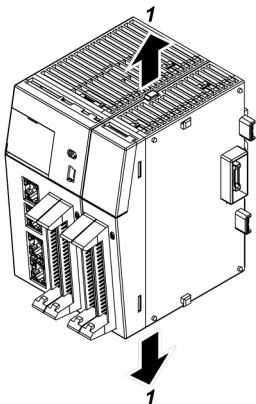

4.1 Installation of the GM1 Series

2. Slide the unit sideways to remove it.

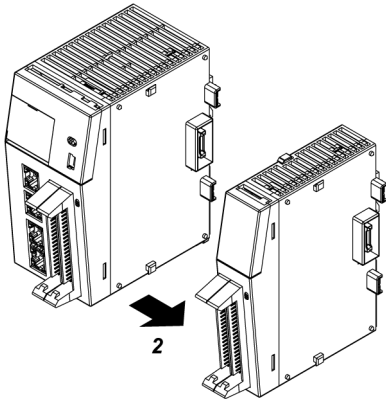

4.1.4 Attaching to DIN Rail

1 2 Procedure

1. Using a screwdriver, push down the DIN rail attachment lever on the back of each unit.

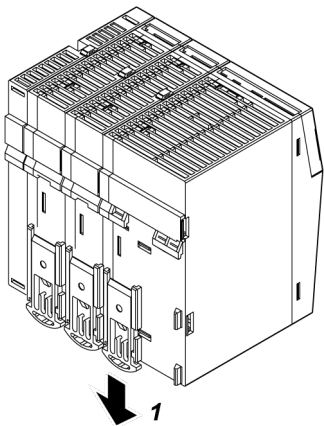

2. Fit the top of the unit attachment part into the DIN rail.
3. While pressing down the unit attachment part onto the DIN rail, fit the bottom of the unit attachment part into the DIN rail.

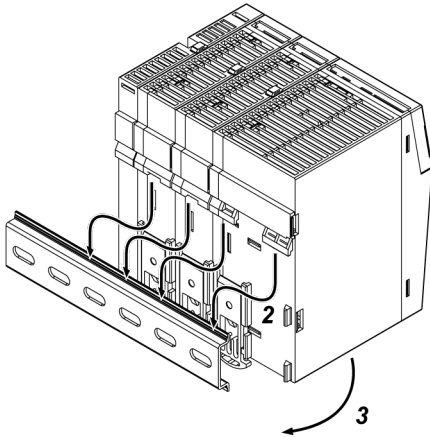

4. Push up the DIN rail attachment lever on the back of the unit until it "clicks" to lock.

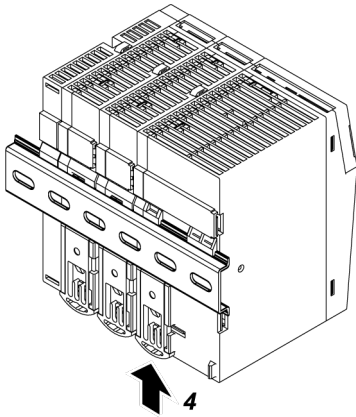

4.1.5 Removing from DIN Rail

1 2 Procedure

1. Using a screwdriver, push down the DIN rail attachment lever on the back of each unit.

4.1 Installation of the GM1 Series

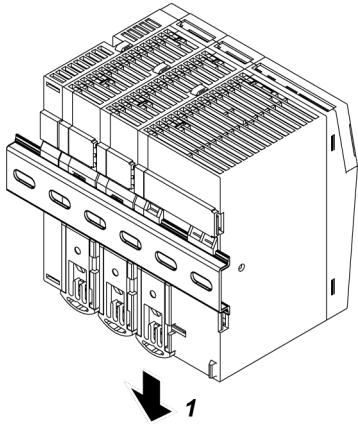

2. Pull the bottom of the unit toward you.
3. While holding up the unit, remove it from the DIN rail.

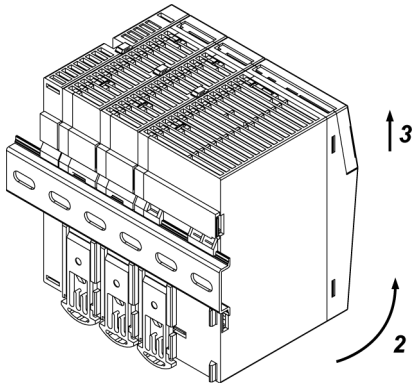

5 Wiring

5.1 Wiring the Power Supply.....	5-2
5.1.1 Common Precautions	5-2
5.1.2 Power Supply for the GM1 Controller (RTEX-compatible / EtherCAT-compatible).....	5-3
5.1.3 Grounding	5-3
5.2 Wiring of Network.....	5-5
5.3 Wiring of Input and Output.....	5-7
5.3.1 Precautions Common to Input and Output.....	5-7
5.3.2 Input Wiring.....	5-7
5.3.3 High-speed Counter Input Wiring.....	5-8
5.3.4 Output Wiring.....	5-10
5.4 Connection Using the Discrete-wire Connector	5-11
5.4.1 Specifications of the Discrete-wire Connector	5-11
5.4.2 Wiring the Discrete-wire Connector	5-12
5.5 Safety Measures	5-15
5.5.1 General Safety Measures	5-15
5.5.2 Momentary Power Failure	5-15
5.5.3 Watchdog Timer	5-15

5.1 Wiring the Power Supply

5.1 Wiring the Power Supply

5.1.1 Common Precautions

■ Selection of a power supply

- Use a low noise power supply.
- The inherent noise resistance is sufficient for the noise superimposed on the power wires, however, the noise can be attenuated further by using the isolation transformer / insulated power supply.

■ Isolation of power supply systems

Wiring to the units, I/O devices, and other power devices should have separate wiring systems.

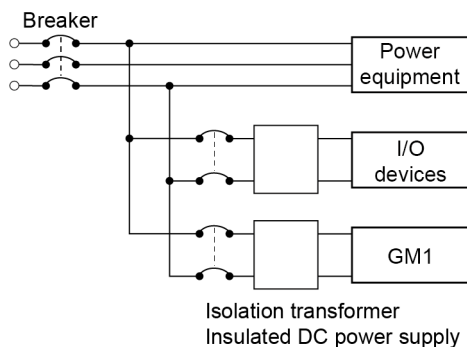

■ Power supply sequence

- Have the power supply sequence such that the power supply of the GM1 Controller (RTEX-compatible / EtherCAT-compatible) turns OFF before the power supply for input and output.
- If the I/O power supplies are turned OFF before the power to the GM1 Controller (RTEX-compatible / EtherCAT-compatible), the GM1 Controller (RTEX-compatible / EtherCAT-compatible) will detect the input fluctuations and may begin an unscheduled operation.

5.1.2 Power Supply for the GM1 Controller (RTEX-compatible / EtherCAT-compatible)

■ Wiring the Power Supply

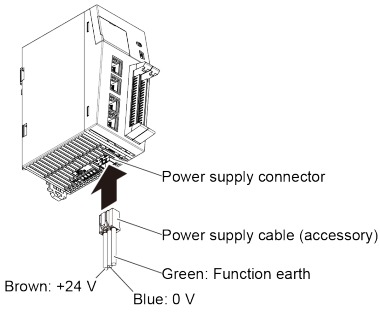
Unit	Wiring diagram
GM1 Controller (RTEX-compatible / EtherCAT-compatible)	 <p>Power supply connector</p> <p>Power supply cable (accessory)</p> <p>Green: Function earth</p> <p>Blue: 0 V</p> <p>Brown: +24 V</p>

■ Selection of a power supply

- To protect the system against erroneous voltage from the power supply line, use an insulated power supply with an internal protective circuit (power supply with reinforced insulation or double insulation).
- The regulator on the unit is a non-insulated type.
- Select a power supply larger than the capacity of the units to be connected. In the minimum configuration, select a power supply of 24 W or larger.

■ Power supply voltage

- Confirm that the voltage of the power supply to be connected is within the allowable range.

Rated input voltage	Allowable voltage range	Rated output capacity
24 V DC	20.4 to 28.8 V DC	24 W or more

■ Power supply cable

- Use the power supply cable (Part No.:AFPG805) that comes with the unit to connect the power supply.
Brown: 24 V DC, Blue: 0 V, Green: Function earth
- Also, twist the power supply cables to minimize adverse effects from noise.

5.1.3 Grounding

■ Use dedicated grounding

- The grounding connection should have a resistance of 100 Ω or less.
- The point of grounding should be as close to the GM1 as possible. The ground wire should be as short as possible.
- Sharing the ground with another device may have an adverse effect. Therefore, be sure that grounding is dedicated.

5.1 Wiring the Power Supply



Possible

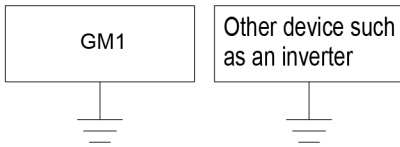

Not possible

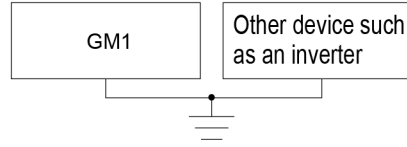

- **Conversely, depending on your environment, grounding may cause a problem.**

As for the GM1 Controller (RTEX-compatible / EtherCAT-compatible), since its power supply line is connected to the function earth through a high-voltage capacitor, it is no problem.

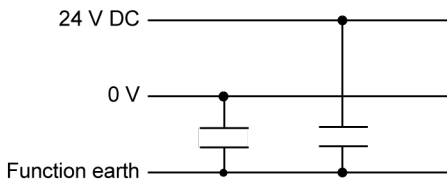

Power supply line to the GM1 expansion unit

- **Do not ground the function earth when grounding a plus (+) terminal of the power.**

When grounding a plus terminal of the power supply, prepare a power supply dedicated to the GM1 and do not ground the plus terminal of the GM1 power supply. In some personal computers, the SG terminal of the internal circuit and shielding are connected. Furthermore, since the power supply circuit for the GM1 is not isolated, if the plus terminal of the power supply is grounded, the power supply will be short circuited to cause a breakdown.

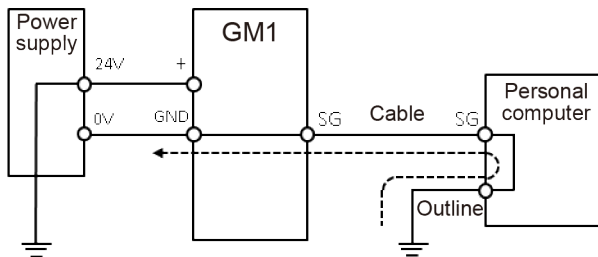

5.2 Wiring of Network

For the wiring of the network, use the LAN cable of the Category 5e shielded cable type. To prevent the cable from coming off, securely connect the connector of the cable to the network connector (RJ45 connector) of the unit.

For RTEX communication

The length between each node should be within 100 m, and the total length of the communication loop should be within 200 m.

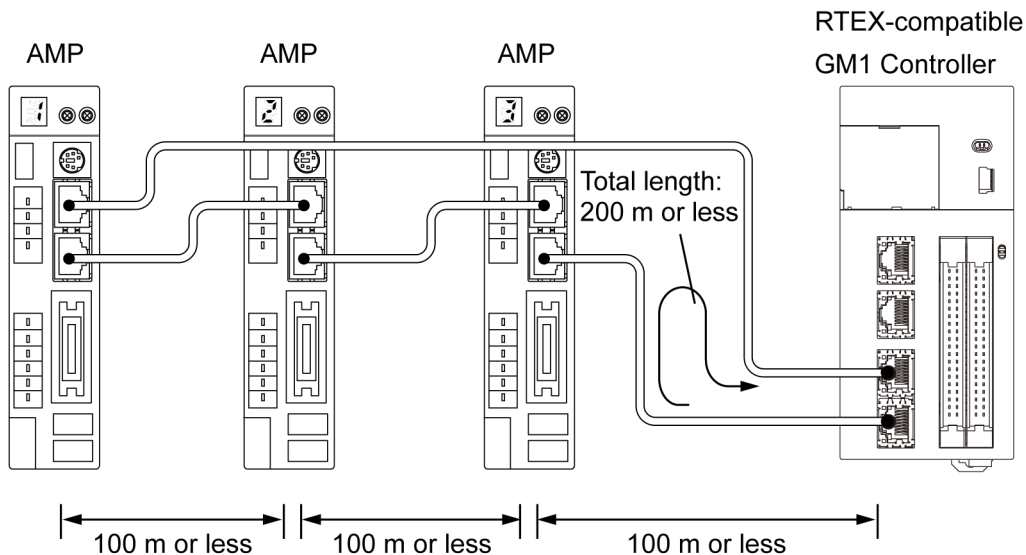

- Connect the cable that is connected to the "TX" of the GM1 Controller (RTEX) to the "X2A Connector (RX)" of the servo amplifier. In the same way, connect between amplifiers from X2B (TX) to X2A (RX). Connect them in a loop in such a way that X2B (TX) of the end amplifier is connected to the "RX" of the GM1 Controller (RTEX)

For EtherCAT communication

The length between each node should be within 100 m, and the total length should be within 200 m.

5.2 Wiring of Network

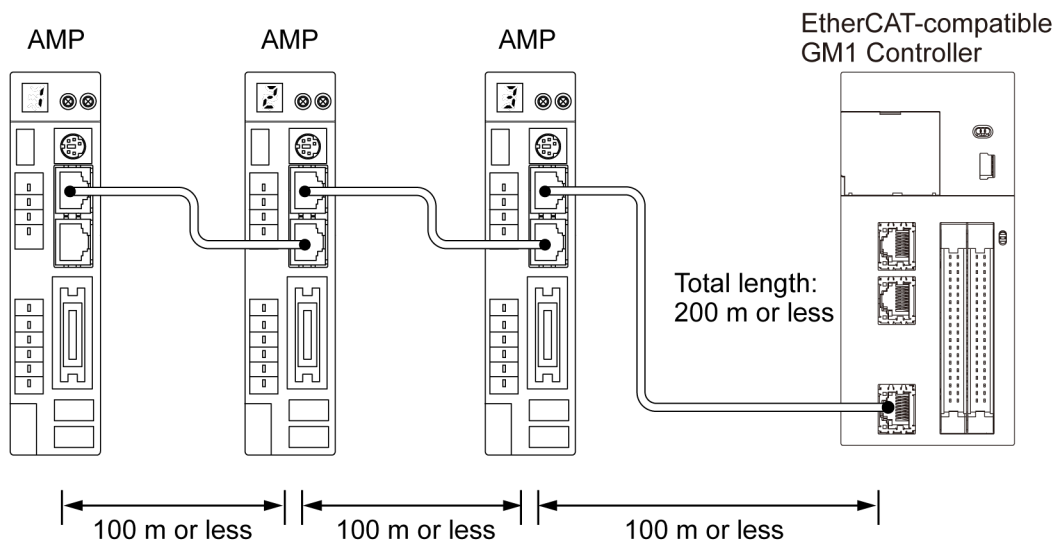

- Connect the cable that is connected to the "EtherCAT port" of the GM1 Controller (EtherCAT) to the "X2A Connector (RX)" of the servo amplifier. In the same way, connect between amplifiers from X2B (TX) to X2A (RX).



- Always use shielded twisted pair (STP) cables that are compatible with category 5e or higher.
- Turn OFF the power to the system before wiring cables.
- The Ethernet hub cannot be used.
- For detailed information of cable specifications and precautions, refer to the data "RTEX Cable" listed on the web page.

https://industrial.panasonic.com/ac/e/dl_center/manual/

5.3 Wiring of Input and Output

5.3.1 Precautions Common to Input and Output

■ Wiring arrangement

Arrange the wiring so that the input and output wiring are separated, and these wirings are separated from the power wiring, as much as possible. Do not route them through the same duct or tie them in a bundle. Separate the I/O wires from the power and high voltage wires by at least 100 mm.

■ Selection of wires

Be sure to select the thickness (dia.) of the input and output wires while taking into consideration the required current capacity.

■ Power supply

Wiring should be carried out after the power supply to the GM1 was turned OFF. Also turn OFF the power supply when connecting the GM1 Controller (RTEX-compatible / EtherCAT-compatible) to expansion units. If they are connected during the power supply is on, it may cause the fault or malfunction.

5.3.2 Input Wiring

■ Connection of photoelectric sensor and proximity sensor

Relay output type

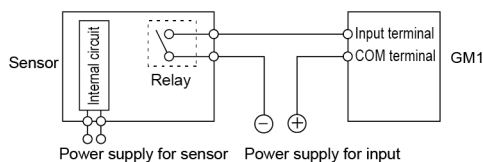

NPN open collector output type

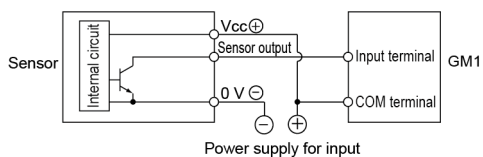

Voltage output type

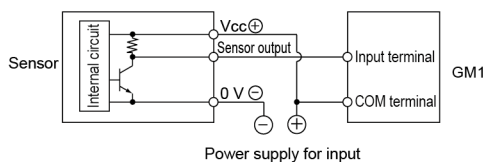

5.3 Wiring of Input and Output

Two-wire output type

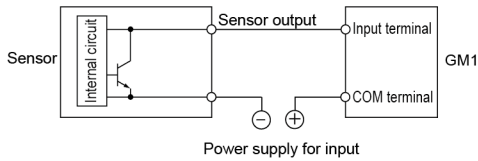

■ Precaution when using LED-equipped reed switch

When a LED is connected in series to an input contact such as LED-equipped reed switch, make sure that the voltage applied to the GM1 input terminal is greater than the ON voltage. In particular, take care when connecting a number of switches in series.

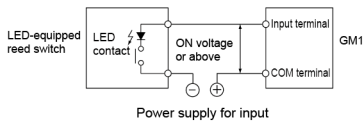

■ Precaution when using two-wire type sensor

If the input to the GM1 does not turn OFF because of leakage current from the two-wire type photoelectric sensor or proximity sensor, connect a bleeder resistor as shown below.

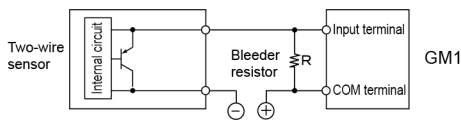

■ Precaution when using LED-equipped limit switch

If the input to the GM1 does not turn OFF because of leakage current from the LED-equipped limit switch, connect a bleeder resistor as shown on below.

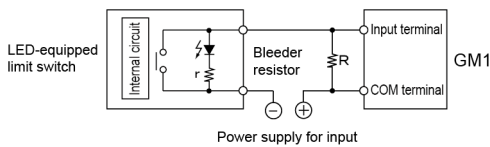

5.3.3 High-speed Counter Input Wiring



- For the connection between the count input (phases A, B, Z) and encoder, etc., use shielded twisted-pair cables.
- The length of connected wires should be 10 m or below.

■ For line driver of encoder input

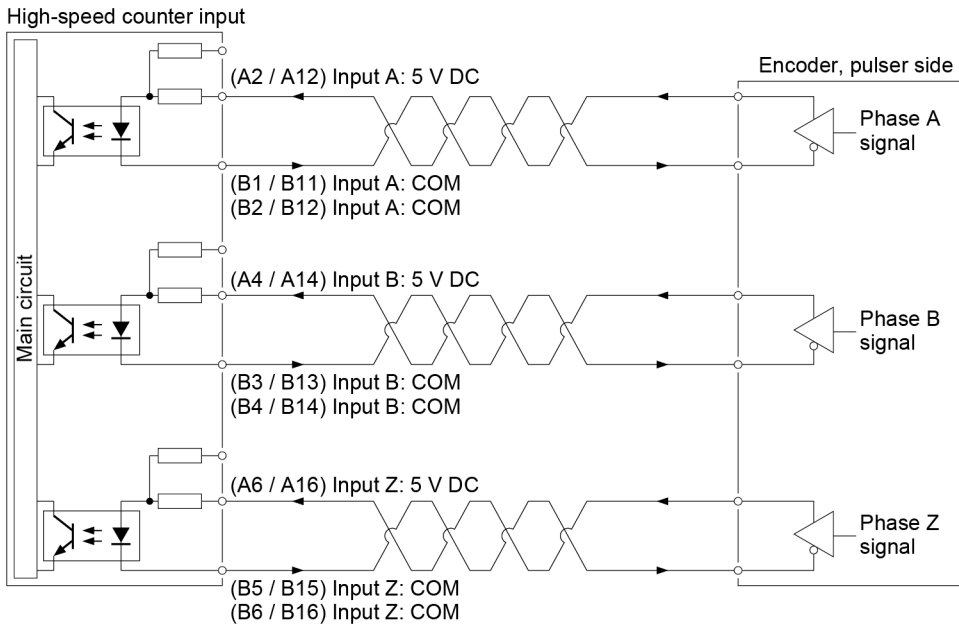

■ For transistor open collector type of encoder input

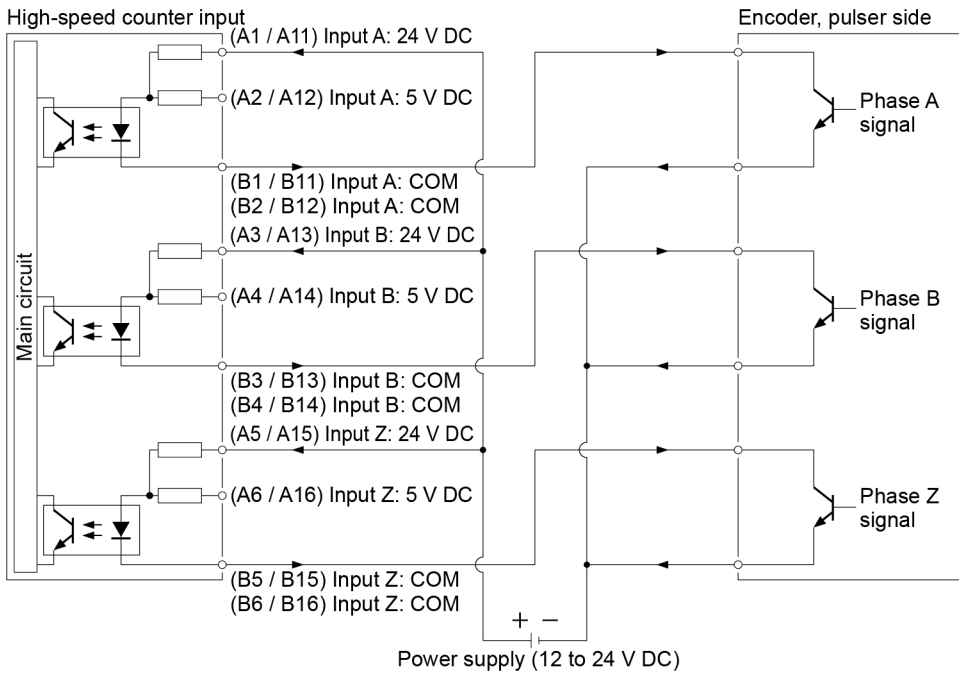

5.3 Wiring of Input and Output

■ For sensor input

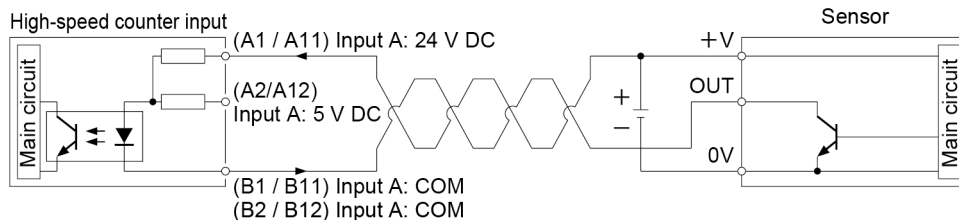

5.3.4 Output Wiring

■ Protective circuit for inductive loads

With an inductive load, a protective circuit should be installed in parallel with the load.

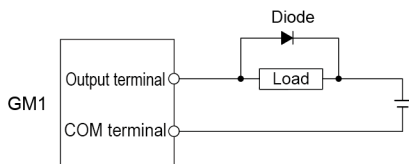

Diode	Reverse breakdown voltage	Three times higher than load voltage or more
	Average rectified current	Higher than load current

■ Precautions when using capacitive loads

When connecting loads with large in-rush currents, to minimize their effect, connect a protection circuit as shown below.

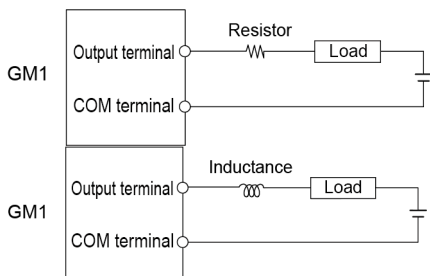

5.4 Connection Using the Discrete-wire Connector

No discrete-wire connector is provided with the unit. Purchase it separately.

5.4.1 Specifications of the Discrete-wire Connector

This is a connector that allows loose wires to be connected without removing the wire's insulation. Use a special tool for wire connection.

Discrete-wire connector (40P)

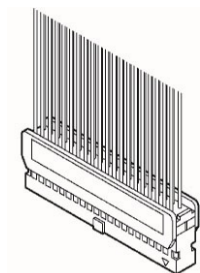

■ AFP2801 Discrete-wire Connector (Purchase separately)

Composition of parts	Quantity (2 sets)
Housing (40P)	1 pc.
Semi-cover (40P)	2 pc.
Contact (For AWG22 and AWG24) 5 pins	8 pc.

■ Compatible wires (stranded wire)

Size	Nominal cross-sectional area	Insulation thickness	Rated current
AWG22	0.3mm ²	Φ1.5 to Φ1.1	3 A
AWG24	0.2mm ²		

■ AXY52000FP Dedicated crimping tool (Purchase separately)

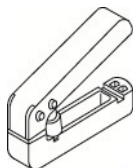

5.4 Connection Using the Discrete-wire Connector

5.4.2 Wiring the Discrete-wire Connector



- When performing wiring work, refer to the instruction manual of the crimping tool in order to prevent faulty wiring.

12

Procedure

1. Bend and break the contact, and set it in the crimping tool.

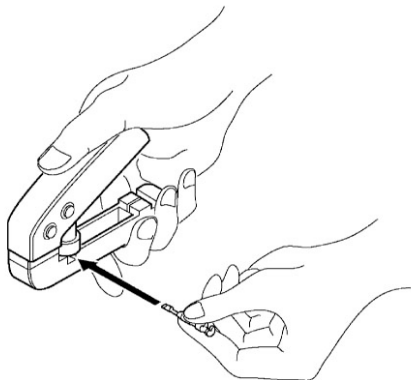

2. Insert the wire without removing its insulation until it stops, and lightly grip the crimping tool.

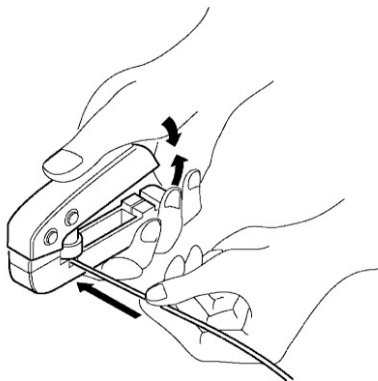

3. The contact appears as shown below after it is crimped. Confirm the following two points.
 1. The wire must be embraced inside the clamped part.
 2. The wire must be inserted to the end.

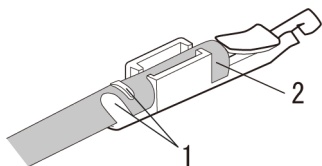

4. Insert the wire with the contact into the housing.

5.4 Connection Using the Discrete-wire Connector

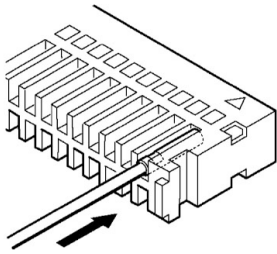

5. When all the wires have been inserted, fit the semi-cover into place.

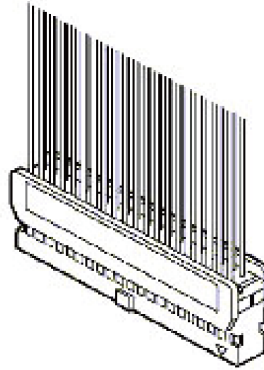
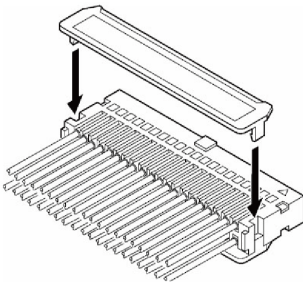

5.4 Connection Using the Discrete-wire Connector

i Info.

- If there is a wiring mistake or the wire is incorrectly press-fit, use the crimping tool to remove the contact.
 1. Set the pin of the crimping tool at the position indicated by an arrow.

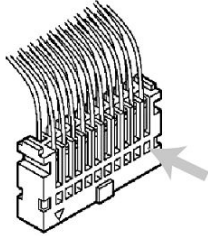

2. Hold the housing with fingers and pull the wire.

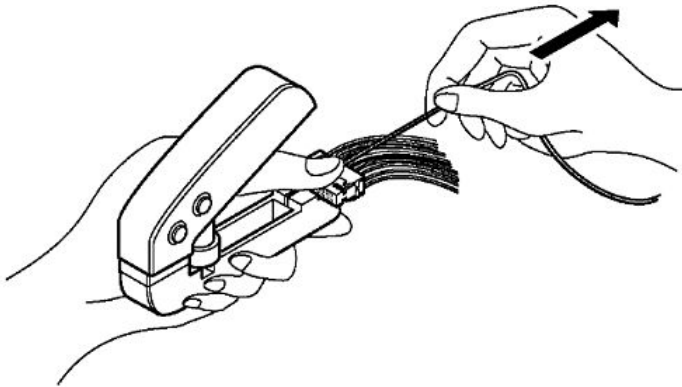

5.5 Safety Measures

5.5.1 General Safety Measures

■ Precautions regarding system design

- In the system where the GM1 is used, malfunction may occur for the following reasons:
 - Power on timing differences between the GM1 system and I/O devices or power devices.
 - Response time lag when a momentary power failure occurs.
 - Abnormality in the GM1 Controller, external power supply, or other devices.

In order to prevent a malfunction resulting in an error or accident of the overall system, take adequate safety measures.

■ Installation of an interlock circuit

- When controlling conflicting operations such as the motor rotation in clockwise or counter-clockwise direction, provide an interlock circuit external to the GM1.

■ Installation of an emergency stop circuit

- Provide an emergency stop circuit external to the GM1 to turn OFF the power supply of the output device.

■ Power supply sequence

- Start the GM1 only after I/O devices and power devices are energized.
- In case of stopping the operation of the GM1, have the I/O devices or power devices turned OFF after the GM1 has stopped operating.

■ Grounding

- When installing the GM1 next to devices that generate high voltages from switching, such as inverters, do not ground them together. Connect an exclusive ground with a resistance of 100 Ω or less.

5.5.2 Momentary Power Failure

■ Operations when a momentary power failure occurs

- If the duration of the momentary power failure is less than 10 ms, the GM1 continues to operate. If the power is off for 10 ms or longer, operation changes depending on the combination of units, the power supply voltage, and other factors. (In some cases, operation may be the same as that for a power supply reset.)

5.5.3 Watchdog Timer

- The watchdog timer is a program error and hardware error detection timer.

5.5 Safety Measures

- When the watchdog timer is activated, the "Alarm" LED on the front of the Controller is lit. When this occurs, all outputs to the output units are turned OFF and the unit is put in halted state.

6 Checking Wiring

6.1 Safety Circuit Design	6-2
6.2 Items to Check during Wiring.....	6-3
6.3 Power ON Operation.....	6-4
6.4 Power OFF Operation.....	6-5

6.1 Safety Circuit Design

6.1 Safety Circuit Design

■ Example of a safety circuit

Be sure to create a safety circuit when using this product.

Installation of over limit switches

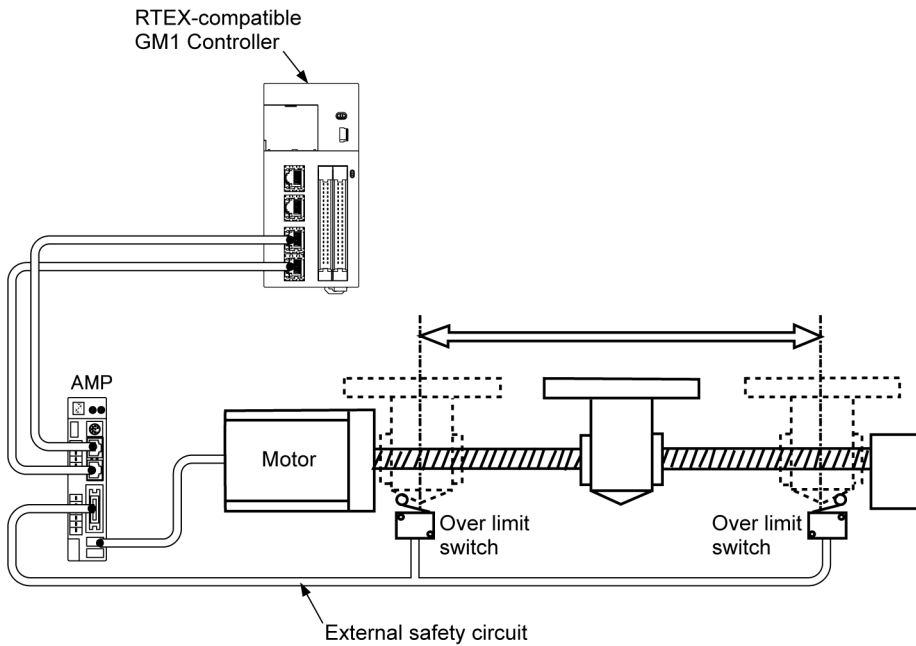

- Install over limit switches as shown above.
- Connect them to the CW and CCW over-travel inhibit inputs of the parallel I/O connector of the servo amplifier. For the GM1 Controller (RTEX-compatible / EtherCAT-compatible), connect them to the limit input (+) and limit input (-) through the network.



- Install the safety circuit recommended by the manufacturer of the motor being used.

6.2 Items to Check during Wiring

■ System configuration example

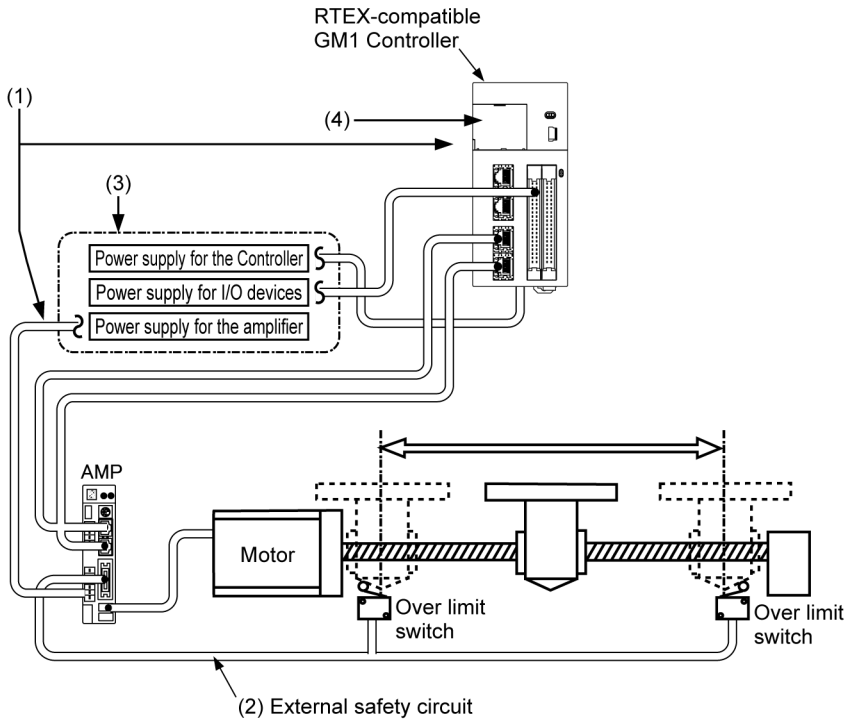

(1) Checking connections of each device

Check to make sure that each device has been connected as indicated by the design.

(2) Checking the installation of the external safety circuit

Check to make sure the safety circuit (wiring and installation of over limit switch) based on the external circuit has been installed properly.

(3) Checking the settings for power ON sequence

Make sure that settings have been entered so that power supplies will be turned ON according to the procedure outlined in "Power ON Operation".

(4) Checking the GM1 Controller (RTEX-compatible / EtherCAT-compatible) mode selector switch

Set the GM1 Controller (RTEX-compatible / EtherCAT-compatible) to the STOP mode. Setting it in the RUN mode can cause inadvertent operation.

6.3 Power ON Operation

6.3 Power ON Operation

When turning ON the power supply to the system incorporating the GM1 Controller (RTEX-compatible / EtherCAT-compatible), turn ON the power supply in the following order.



- Consider the nature and statuses of any external devices connected to the system, and take sufficient care so that turning ON the power supply will not initiate unexpected movements.

1 2 Procedure

1. Turn ON the power supplies to the I/O devices connected to the GM1 Controller (RTEX-compatible / EtherCAT-compatible).
2. Turn ON the power supply to the servo amplifier.
3. Turn ON the power supply to the GM1 Controller (RTEX-compatible / EtherCAT-compatible).

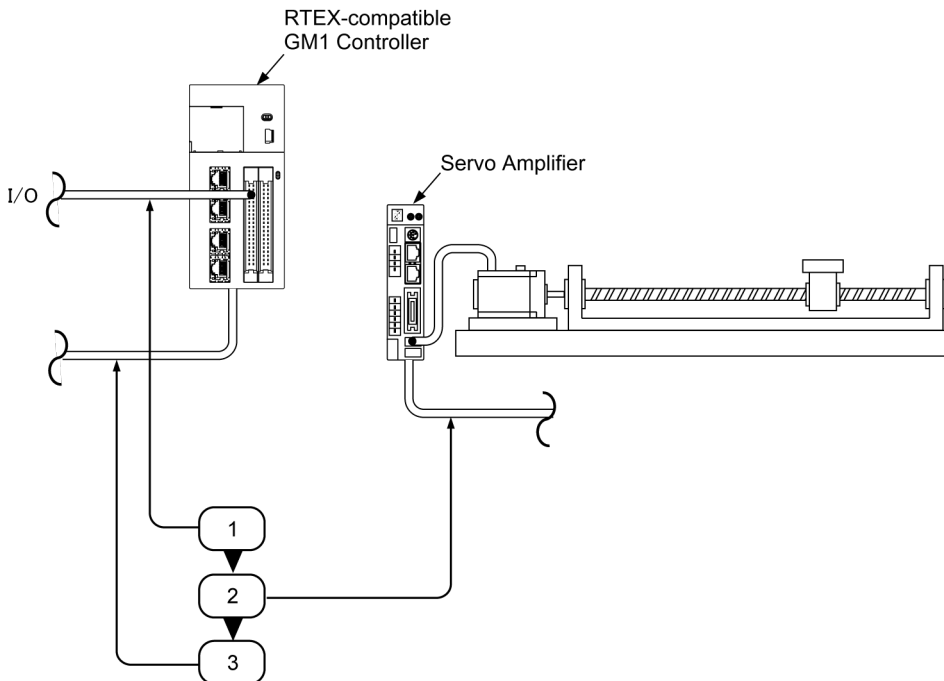

6.4 Power OFF Operation

1 2 Procedure

1. Check to make sure the rotation of the motor has stopped, and then turn OFF the power supply to the GM1 Controller (RTEX-compatible / EtherCAT-compatible).
2. Turn OFF the power supply to the servo amplifier.
3. Turn OFF the power supplies to the I/O devices connected to the GM1 Controller (RTEX-compatible / EtherCAT-compatible).

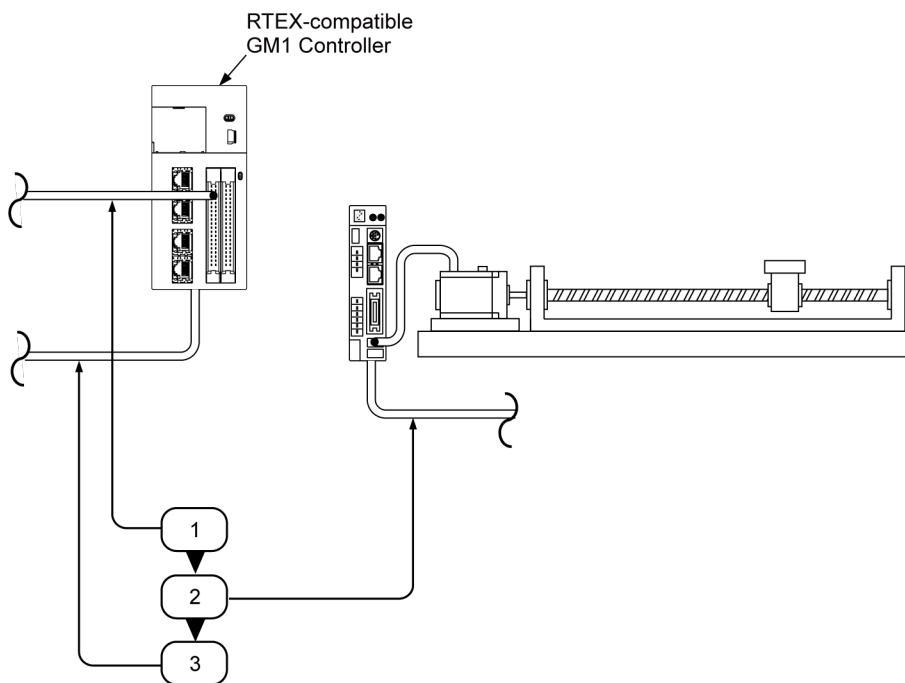

(MEMO)

7 Using the SD Memory Card and SDHC Memory Card

7.1 Preparation of the SD Memory Card and SDHC Memory Card.....	7-2
7.2 Inserting the SD Memory Card and SDHC Memory Card	7-3

7.1 Preparation of the SD Memory Card and SDHC Memory Card

7.1 Preparation of the SD Memory Card and SDHC Memory Card

■ Usable SD memory card and SDHC memory cards

We recommend SLC SD Memory Cards and SLC SDHC Memory Cards.

Logo printed on the GM1 Controller (RTEX-compatible / EtherCAT-compatible)	Usable SD (SDHC) memory cards	
	Card type	Capacity
	SD memory card	2 GB
	SDHC memory card	4 GB to 32 GB

■ Precautions on handling the SD memory card and SDHC memory card

The data saved in the SD memory card or in the SDHC memory card may be lost in the following cases. We assume no responsibility whatsoever for the loss of saved data.

- When the user or a third party has misused the SD memory card or SDHC memory card
- When the SD memory card or SDHC memory card was affected by any static electricity or electrical noise
- When the SD memory card or SDHC memory card was taken out, or the power supply to the GM1 Controller (RTEX-compatible / EtherCAT-compatible) was turned OFF, while the card was being accessed to save or delete data



- It is recommended to save important data in another media for backup.
- Never remove the card or turn OFF the power supply to the GM1 Controller (RTEX-compatible / EtherCAT-compatible) while the "SD" LED on the GM1 Controller (RTEX-compatible / EtherCAT-compatible) is lit (data is being read from or written into the card). Data may be damaged.
- Do not use an SD memory card or SDHC memory card that has a memory capacity larger than the usable capacity. Data in the card may be damaged.
- Implements SD memory card or SDHC memory card management to prevent data in the card from being leaked to third parties.

■ Formatting the SD memory card and SDHC memory card

In principle, the SD memory card and SDHC memory card have been formatted by the time of purchase, and no formatting by the user is required. If formatting becomes necessary, download the SD formatter software from the SD association site and format the memory card.

Info.

- The SD memory card or SDHC memory card file system formatted by PC's standard formatting software does not satisfy the SD memory card or SDHC memory card specifications. Please use the dedicated formatting software.

7.2 Inserting the SD Memory Card and SDHC Memory Card



- Do not apply an excessive force to the card cover when opening or closing it or when the cover is left open. Otherwise, the cover attachment part will be deformed to cause malfunction in the cover switch mounted inside the product.

1 2 Procedure

1. Insert the tip of a flat blade screw driver into the cavity on the card cover to open the cover.

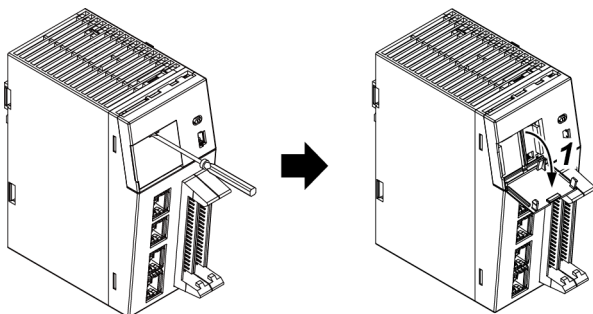

2. Insert the SD memory card or SDHC memory card into the SD memory card slot until it is locked in place.

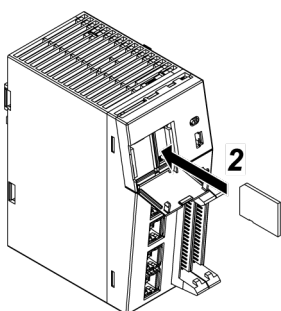

3. Close the SD memory card cover.

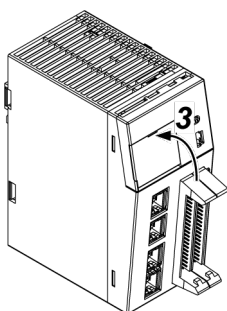

7.2 Inserting the SD Memory Card and SDHC Memory Card

Info.

When removing the SD memory card or SDHC memory card, make sure that the "SD" LED on the GM1 Controller (RTEX-compatible / EtherCAT-compatible) is not lit.

8 Device Reset

8.1 Device Reset by GM1 Controller Operation.....8-2

8.1 Device Reset by GM1 Controller Operation

8.1 Device Reset by GM1 Controller Operation

Controller information on the GM Programmer can be deleted (initialized) from the GM1 Controller.

1 2 Procedure

1. Confirm that the power supply is turned OFF, set the mode selector switch to "STOP", and set SW2 (reset bit) of the DIP switch to "ON".
2. When the power supply is turned ON, the [RUN] [STOP] [ERROR] LEDs are lit and a device reset is executed.
3. When the [RUN] [STOP] [ERROR] LEDs go out, the device reset is completed. When the device reset is completed, turn "OFF" the power supply, and set the reset bit to "OFF".

Note

Device reset can be executed from the GM1 Controller as well as from GM Programmer. For details on the device reset, refer to the *GM1 Controller RTEX User's Manual (Operation)* or *GM1 Controller EtherCAT User's Manual (Operation)*.

9 Troubleshooting

9.1 Self-diagnostic Function.....	9-2
9.2 Operation Status at the Time of Error	9-3
9.3 What to Do If an Error Occurs.....	9-4
9.3.1 ERROR LED Flashes on the Control Unit	9-4
9.3.2 ALARM LED Lights on the Control Unit	9-4
9.3.3 POWER LED Does not Light on the Control Unit	9-5
9.3.4 Desired Output Is Not Obtained: Checking when the Output Does Not Turn ON / OFF	9-5
9.3.5 Desired Input Is Not Obtained: Checking when the Input Does Not Turn ON / OFF	9-6
9.3.6 If the ALARM LED Is Lit on the Expansion Unit.....	9-6
9.3.7 If the ALARM LED Is Unlit on the Expansion Unit	9-7

9.1 Self-diagnostic Function

9.1 Self-diagnostic Function

The GM1 Controller (RTEX-compatible / EtherCAT-compatible) has a self-diagnostic function which identifies errors and stops operation if necessary.

Indications concerning self-diagnosis are as follows.

■ LEDs related to self-diagnostic errors

●: Lit, ▲: Flashing, ○: Unlit, —: Indefinite (Lit or unlit)

	LED display				Description	Operation status
	RUN	STOP	ERROR	ALARM		
Normal	●	○	○	○	Normal operation	Operating
	○	●	○	○	STOP mode	Stopped
Error	●	○	▲	○	When a self-diagnostic error occurs (Operation continues.)	Operating
	○	●	▲	○	When a self-diagnostic error occurs (Operation stops.)	Stopped
	○	●	-	●	System error	Stopped

9.2 Operation Status at the Time of Error

■ PLC parameter setting

Operation mode at the time of error can be set to continue operation or stop operation in the PLC parameter setting.

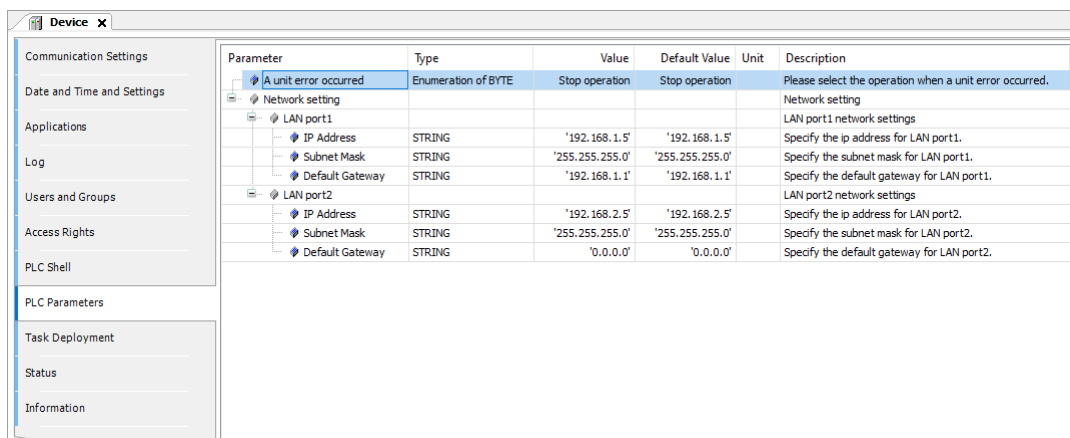

The screenshot shows a software interface for configuring PLC parameters. On the left is a navigation pane with categories: Communication Settings, Date and Time and Settings, Applications, Log, Users and Groups, Access Rights, PLC Shell, PLC Parameters, Task Deployment, Status, and Information. The main area displays a tree view of parameters under 'Network setting', which is expanded to show 'LAN port1' and 'LAN port2'. A table below the tree lists the parameters and their values.

Parameter	Type	Value	Default Value	Unit	Description
A unit error occurred	Enumeration of BYTE	Stop operation	Stop operation		Please select the operation when a unit error occurred.
Network setting					Network setting
LAN port1					LAN port1 network settings
IP Address	STRING	'192.168.1.5'	'192.168.1.5'		Specify the ip address for LAN port1.
Subnet Mask	STRING	'255.255.255.0'	'255.255.255.0'		Specify the subnet mask for LAN port1.
Default Gateway	STRING	'192.168.1.1'	'192.168.1.1'		Specify the default gateway for LAN port1.
LAN port2					LAN port2 network settings
IP Address	STRING	'192.168.2.5'	'192.168.2.5'		Specify the ip address for LAN port2.
Subnet Mask	STRING	'255.255.255.0'	'255.255.255.0'		Specify the subnet mask for LAN port2.
Default Gateway	STRING	'0.0.0.0'	'0.0.0.0'		Specify the default gateway for LAN port2.

9.3 What to Do If an Error Occurs

9.3 What to Do If an Error Occurs

9.3.1 ERROR LED Flashes on the Control Unit

■ Condition

A self-diagnostic error has occurred.

■ Solution

Check the condition according to the following procedure.

1. On the GM Programmer, select **Online>Status** and check the error content (error code).
2. Switch to the STOP mode.
3. On the Status screen of the GM Programmer, check the error information.
In case of an operation continue error, the error can be resolved by RTEX Reset / Error Clear.

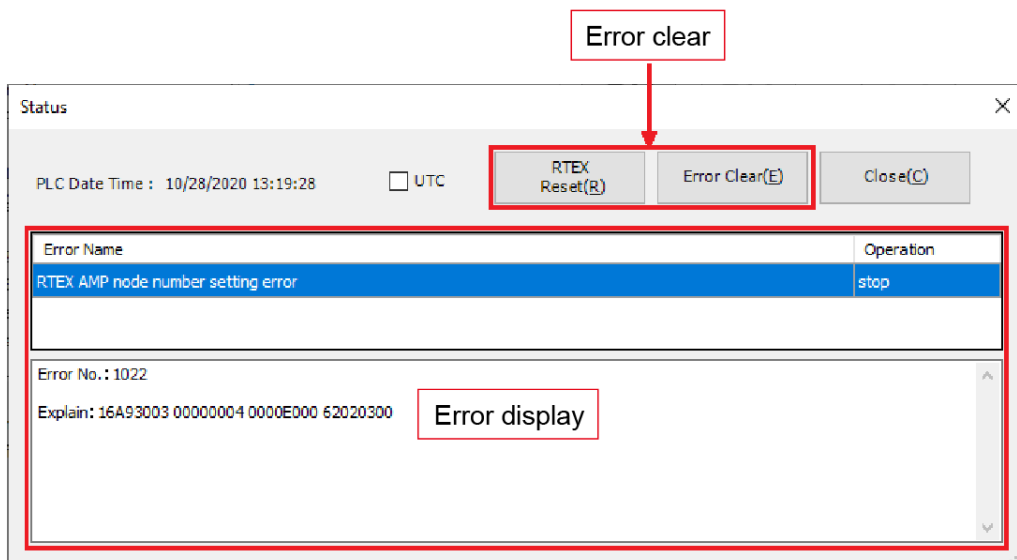

4. Cancel the situation in accordance with the error code.

i Info.

- For the error codes, refer to the , *GM1 Controller RTEX User's Manual (Operation)* or *GM1 Controller EtherCAT User's Manual (Operation)*.

9.3.2 ALARM LED Lights on the Control Unit

■ Condition

The system watchdog timer has been activated and the operation of the Controller has stopped.

■ Solution

1. Set the control unit to STOP mode and restart the power supply.
If the ALARM LED lights again, there may be a problem with the unit.
If it goes out, the problem may have been caused by primary factors such as a noise.
2. Check the surrounding environment if there is an influence of noise.
If there is no problem with the program, there might be a problem with the surrounding environment.
Check the wiring including installation wiring.
Particularly, check if wiring to the control unit is routed too close to the power line wiring and also check if necessary shield processing has been performed.

9.3.3 POWER LED Does not Light on the Control Unit

■ Condition

It is possible that sufficient power is not supplied.

■ Solution

1. Power off the unit and double-check the wiring status. (e.g. Is there any loose terminal?)
2. Check if the output of the power supply to the control unit does not exceed the rating.
If the 24-V power supply is not sufficient, review the power supply configuration.
Disconnect the power supply wiring to the other devices if the power supplied to the control unit is shared with them.

9.3.4 Desired Output Is Not Obtained: Checking when the Output Does Not Turn ON / OFF

■ Condition

Both software factors such as program or I/O allocation and hardware factors such as wiring or power supply can be assumed.

■ Solution

1. Check if the output display LED of the unit is lit.
If it is lit, proceed to the following step. If it is not lit, proceed to step 4.
2. Recheck the wiring of the loads for loose terminals, etc.
3. Check if proper voltage is applied to the loads.

9.3 What to Do If an Error Occurs

If the voltage is properly applied to the load, there is probably an abnormality in the load.
If the voltage is not applied to the load, there is probably an abnormality in the output section of the unit.

4. Using the GM Programmer, check the monitor function by forcibly setting or resetting the output.
If the output LED of the unit changes, it is possible that the output has been overwritten in the program.
If the LED does not change, there is probably an abnormality in the output section of the unit.

9.3.5 Desired Input Is Not Obtained: Checking when the Input Does Not Turn ON / OFF

■ Condition

Both software factors such as program or I/O allocation and hardware factors such as wiring or power supply can be assumed.

■ Solution

1. If the input display LED is unlit, proceed to the following step. If it is lit, proceed to step 4.
2. Recheck the wiring of the input devices for loose terminals, etc.
3. Check if the voltage is properly applied to the input terminals.
If the voltage is properly applied to the input terminals, there is probably an abnormality in the unit's input part.
If the voltage is not applied to the input terminal, there is probably an abnormality in the power supply or the input device.
4. Using the GM Programmer, monitor the input state.
If the monitored state is OFF, there is probably an abnormality with the input unit.
If the monitored state is ON, there is probably an abnormality with the program.

9.3.6 If the ALARM LED Is Lit on the Expansion Unit

■ Condition

If the ALARM LED is lit on the expansion unit, there may be a system failure.

■ Solution

1. Turn the system OFF and then ON.
2. If the system is not reset, there may be a hardware failure. Please consult your Panasonic representative.

9.3.7 If the ALARM LED Is Unlit on the Expansion Unit

■ Condition

It can be assumed that a system error has occurred in the expansion unit connected to the control unit or in the control unit.

■ Solution

Clarify the situation in the following procedure.

1. Check if an end unit is connected to the last expansion unit.
2. Check the wiring of the cables connected to the expansion units and wiring of the power supply.
3. Clear the self-diagnosis error of the control unit.
4. Restart the power supply of the control unit.

(MEMO)

10 Maintenance and Inspection

10.1 Inspection.....10-2

10.1 Inspection

10.1 Inspection

To always use the unit in optimal conditions, carry out routine or periodic inspections.

Inspection items

Inspection item	Inspection details	Criterion	Related page
Installation status	Mounting on DIN rail, looseness, and unit looseness and backlash	The unit must have been installed properly.	"P.4-4"
Connection status	Connector looseness	Each connector must not be loose.	"P.6-3"
Usage conditions	Ambient temperature (in-panel temperature) Ambient humidity (in-panel humidity) Atmosphere	0 to +55°C 10 to 95%RH Free of dust and corrosive gases	"P.11-4"

11 Specifications and Dimensions

11.1	General Specifications	11-2
11.2	Specifications of the GM1 Controller.....	11-4
11.2.1	High-speed Counter Input Specifications of the GM1 Controller....	11-4
11.2.2	Input Specifications of the GM1 Controller.....	11-4
11.2.3	Output Specifications of the GM1 Controller (Sink Type)	11-5
11.2.4	Output Specifications of the GM1 Controller (Source Type)	11-6
11.3	Specifications of Expansion Units	11-8
11.3.1	Input Specifications of the 64-point Digital Input Unit	11-8
11.3.2	Output Specifications of the 64-point Digital Output Unit (Sink Type).....	11-9
11.3.3	Output Specifications of the 64-point Digital Output Unit (Source Type).....	11-11
11.3.4	I/O Specifications of the 64-point Digital I/O Unit (Sink Type).....	11-12
11.3.5	I/O Specifications of the 64-point Digital I/O Unit (Source Type)....	11-15
11.3.6	Input Specifications of the Analog Input Unit	11-18
11.3.7	Output Specifications of the Analog Output Unit.....	11-19
11.3.8	Performance Specifications of the Pulse Output Unit	11-20
11.4	Communication Specifications	11-24
11.4.1	Specifications of the USB Port	11-24
11.4.2	Specifications of the COM Port (RS-232C).....	11-24
11.4.3	Specifications of the LAN Port.....	11-25
11.4.4	Specifications of the RTEX Port.....	11-25
11.4.5	Specifications of the EtherCAT Port	11-26
11.5	Performance Specifications	11-27
11.6	Dimensions	11-28
11.6.1	Dimensions of the GM1 Controller	11-28
11.6.2	Dimensions of the GM1 Expansion Unit.....	11-29
11.7	Conformance to international standards	11-32
11.7.1	List of conformed standards for motion controllers	11-32
11.7.2	About Radio Waves Act(South Korea)	11-32

11.1 General Specifications

11.1 General Specifications

Item	Specifications
Rated voltage	24 V DC
Operating voltage range	20.4 to 28.8 V DC
Allowable momentary power failure time	10 ms
Operating ambient temperature	0 to +55°C
Storage ambient temperature	-40 to +70°C
Operating ambient humidity	10 to 95% RH (at +25°C, no condensation or icing)
Storage ambient humidity	10 to 95% RH (at +25°C, no condensation or icing)
Dielectric strength (Leakage current: 5 mA)	500 V AC for one minute (Between input terminals, all output terminals and power supply terminal, all function earths, between all input terminals and all output terminals, between all general-purpose input terminals and all counter input terminals)
Insulation resistance (Test voltage: 500 V DC)	100 MΩ or more (Between input terminals, all output terminals and power supply terminal, all function earths, between all input terminals and all output terminals, between all general-purpose input terminals and all counter input terminals)
Vibration resistance	Compliant with JIS B 3502, IEC 61131-2 5 to 8.4 Hz, half amplitude 3.5 mm, 8.4 to 150 Hz acceleration 9.8 m/s ² 10 sweeps each in X, Y and Z directions (1 octave/min)
Shock resistance	Compliant with JIS B 3502, IEC 61131-2 147 m/s ² , 3 times each in the X, Y, Z directions
Noise resistance	1000 V [p-p] with pulse widths of 1 μs and 50 ns (using a noise simulator) (Power supply terminal)
Atmosphere	Free of corrosive gases No excessive dust
European EU Standards	EMC : EN 61131-2 RoHS : EN IEC 63000
Overvoltage category	Category II
Pollution degree	2

List of weights (main units)

Unit type		Weight (main unit)
RTEX-compatible GM1 Controller	AGM1CSRX16T	Approx. 370 g (including the terminal block and end cover)
EtherCAT-compatible GM1 Controller	AGM1CSEC16T	Approx. 370 g (including the terminal block and end cover)
	AGM1CSEC16P	
Digital I/O Unit	AGM1X64D2	Approx. 160 g (including the terminal block)
	AGM1Y64T	Approx. 160 g (including the terminal block)
	AGM1Y64P	Approx. 160 g (including the terminal block)
	AGM1XY64D2T	Approx. 160 g (including the terminal block)

Unit type		Weight (main unit)
	AGM1XY64D2P	Approx. 160 g (including the terminal block)
Analog I/O Unit	AGM1AD8	Approx. 150 g (including the terminal block)
	AGM1DA4	Approx. 150 g (including the terminal block)
Pulse Output Unit	AGM1PG04T	Approx. 160 g (including the terminal block)
	AGM1PG04L	Approx. 160 g (including the terminal block)

List of consumption current

Unit type		Consumption current
RTEX-compatible GM1 Controller	AGM1CSRX16T	400 mA or less
EtherCAT-compatible GM1 Controller	AGM1CSEC16T	400 mA or less
	AGM1CSEC16P	400 mA or less
Expansion Units	AGM1X64D2	90 mA or less
	AGM1Y64T	160 mA or less
	AGM1Y64P	160 mA or less
	AGM1XY64D2T	120 mA or less
	AGM1XY64D2P	120 mA or less
	AGM1AD8	130 mA or less
	AGM1DA4	160 mA or less
	AGM1PG04T	100 mA or less
	AGM1PG04L	100 mA or less

11.2 Specifications of the GM1 Controller

11.2 Specifications of the GM1 Controller

11.2.1 High-speed Counter Input Specifications of the GM1 Controller

Item	Specifications		
	Input A, B, Z signals		
	24 V DC	5 V DC	
Open collector connection		Line driver connection	
Insulation method	Optical coupler		
Rated input voltage	12 V DC to 24 V DC	5 V DC	Equivalent to AM26LS31
Operating voltage range	10.8 V DC to 26.4 V DC	3.5 V DC to 5.5 V DC	
Input points per common	Independent common for each point		
Min. ON voltage / Min. ON current	10 V DC / 4 mA	3 V DC / 4 mA	
Max. OFF voltage / Max. OFF current	2 V DC / 2 mA	1 V DC / 0.5 mA	
Input impedance	Approx. 3.9 k Ω	Approx. 560 Ω	
Operating mode indicator	6-point LED display		

11.2.2 Input Specifications of the GM1 Controller

■ Input specifications

Item	Specifications	
Insulation method	Optical coupler	
Rated input voltage	24 V DC	
Rated input current	Approx. 3 mA (at 24 V DC)	
Input impedance	Approx. 6.8 k Ω	
Operating voltage range	21.6 to 26.4 V DC	
Min. ON voltage / Min. ON current	19.2 V / 6 mA	
Max. OFF voltage / Max. OFF current	2.4 V / 1 mA	
Response time	OFF→ON	135 μ s max. (Possible to change by using the input time constant selection function)
	ON→OFF	135 μ s max. (Possible to change by using the input time constant selection function)
Input points per common	16 points/1 common	
Operating mode indicator	16-point LED display (Lit when ON, SW selection)	
External connection method	Connector connection (Compliant with the MIL standard, 40P)	

Internal circuit diagram of the GM1 Controller input section

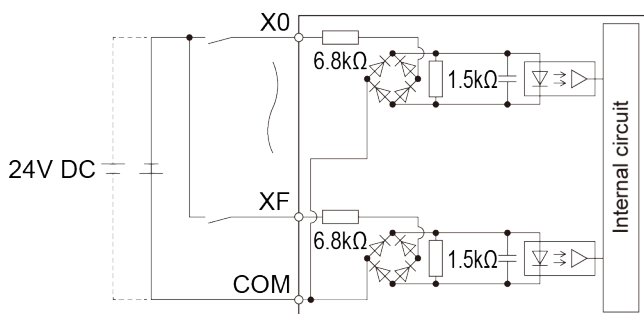

Limitations on the number of simultaneous input ON points of the GM1 Controller

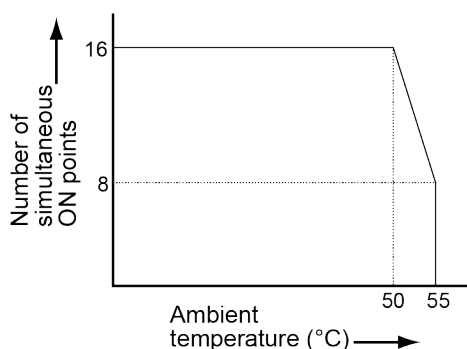

11.2.3 Output Specifications of the GM1 Controller (Sink Type)

Output specifications (sink type)

Item	Specifications	
Insulation method	Optical coupler	
Output type	NPN open collector	
Rated load voltage	5 to 24 V DC	
Allowable load voltage range	4.75 to 26.4 V DC	
Max. load current	0.3 A	
Common restrictions	3.2 A/common	
Max. inrush current	1.0 A	
OFF state leakage current	1 μA or less	
ON state max. voltage drop	0.7 V or less	
Response time	OFF→ON	6 μs or less (at an ambient temperature of 25°C)
	ON→OFF	15 μs or less (at an ambient temperature of 25°C)
External power supply	Voltage	4.75 to 26.4 V DC

11.2 Specifications of the GM1 Controller

Item	Specifications
Current	35 mA/common (at 24 V)
Surge absorber	Zener diode
Short-circuit protection	Provided (to automatically protect every eight points) ^(Note 1)
Input points per common	16 points/1 common
Operating mode indicator	16-point LED display (Lit when ON, SW selection)
External connection method	Connector connection (Compliant with the MIL standard, 40P)

(Note 1) When the maximum inrush current is exceeded, eight output points in the same protection block are turned OFF simultaneously.

Internal circuit diagram of the GM1 Controller (sink type) output section

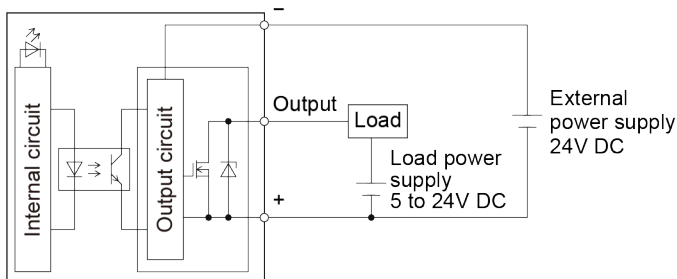

Limitations on the number of simultaneous output ON points of the GM1 Controller (Sink Type)

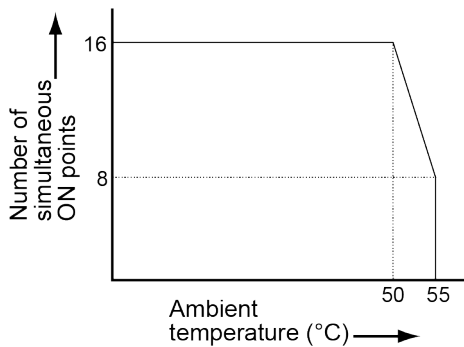

11.2.4 Output Specifications of the GM1 Controller (Source Type)

Output specifications (source type) (EtherCAT-compatible GM1 Controller only)

Item	Specifications
Insulation method	Optical coupler
Output type	PNP open collector
Rated load voltage	24 V DC

Item	Specifications	
Allowable load voltage range	21.6 to 26.4 V DC	
Max. load current	0.3 A	
Max. inrush current	1.0 A	
OFF state leakage current	2 μ A or less	
ON state max. voltage drop	0.7 V or less	
Response time	OFF→ON	6 μ s or less (at an ambient temperature of 25°C)
	ON→OFF	15 μ s or less (at an ambient temperature of 25°C)
External power supply	Voltage	21.6 to 26.4 V DC
	Current	30 mA/common (at 24 V)
Surge absorber	Zener diode	
Short-circuit protection	Provided (to automatically protect every eight points) ^(Note 1)	
Input points per common	16 points/1 common	
Operating mode indicator	16-point LED display (Lit when ON, SW selection)	
External connection method	Connector connection (Compliant with the MIL standard, 40P)	

(Note 1) When the maximum inrush current is exceeded, eight output points in the same protection block are turned OFF simultaneously.

■ Internal circuit diagram of the GM1 Controller Output section

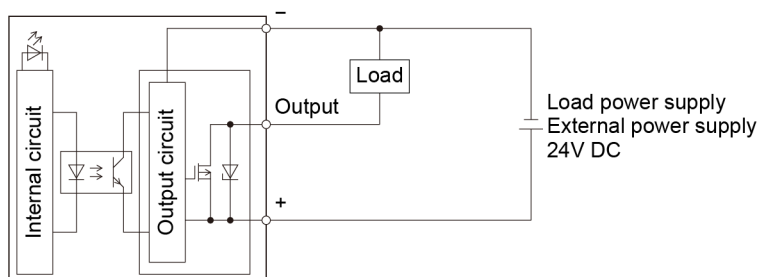

■ Limitations on the number of simultaneous output ON points of the GM1 Controller

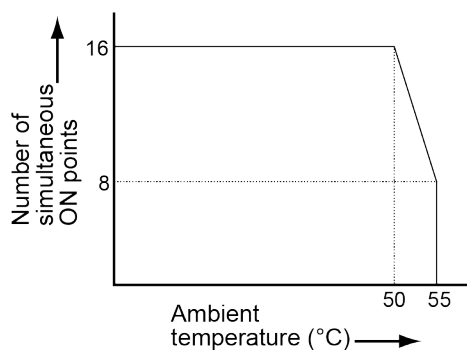

11.3 Specifications of Expansion Units

11.3 Specifications of Expansion Units

11.3.1 Input Specifications of the 64-point Digital Input Unit

■ Input specifications

Item		Specifications
Insulation method		Optical coupler
Rated input voltage		24 V DC
Rated input current		Approx. 2.7 mA (at 24 V DC)
Input impedance		Approx. 6.8 k Ω
Operating voltage range		20.4 to 26.4 V DC
Min. ON voltage / Min. ON current		19.2 V / 2.5 mA
Max. OFF voltage / Max. OFF current		5 V / 1.5 mA
Response time	OFF→ON	0.2 ms max. (Possible to change by using the input time constant selection function)
	ON→OFF	0.2 ms max. (Possible to change by using the input time constant selection function)
Input points per common		32 points/1 common
Operating mode indicator		Operating mode indicator: 32-point LED display (Lit when ON, SW selection)
External connection method		Connector connection (Compliant with the MIL standard, 40P, two pieces used)

■ Internal circuit diagram of the 64-point digital input unit

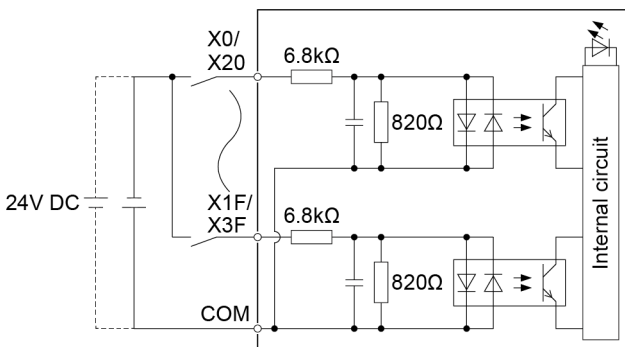

■ **Limitations on the number of simultaneous input ON points of the 64-point digital input unit**

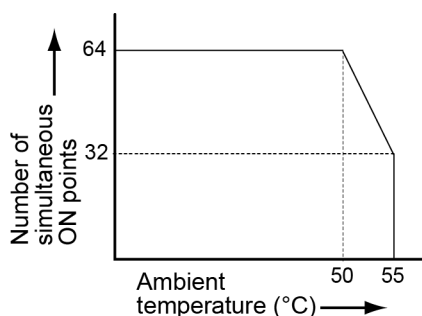

11.3.2 Output Specifications of the 64-point Digital Output Unit (Sink Type)

■ **Output specifications (sink type)**

Item		Specifications
Insulation method		Optical coupler
Output type		Open collector
Rated load voltage		5 to 24 V DC
Allowable load voltage range		4.75 to 26.4 V DC
Max. load current		0.3 A (20.4 to 26.4 V DC), 30 mA (4.75 V DC)
Common restrictions		3.2 A/common
Max. inrush current		0.6 A
OFF state leakage current		1 μ A or less
ON state max. voltage drop		0.5 V or less
Response time	OFF→ON	0.1 ms or less (Load current: 2 mA or more)
	ON→OFF	0.3 ms or less (Load current: 2 mA or more)
External power supply	Voltage	4.75 to 26.4 V DC
	Current	70 mA/common (at 24 V)
Surge absorber		Zener diode
Short-circuit protection		None
Input points per common		32 points/1 common
Operating mode indicator		32-point LED display (Lit when ON, selection using the display selector switch)
External connection method		Connector connection (Compliant with the MIL standard, 40P, two pieces used)

11.3 Specifications of Expansion Units

■ Internal circuit diagram of the 64-point digital output unit (sink type)

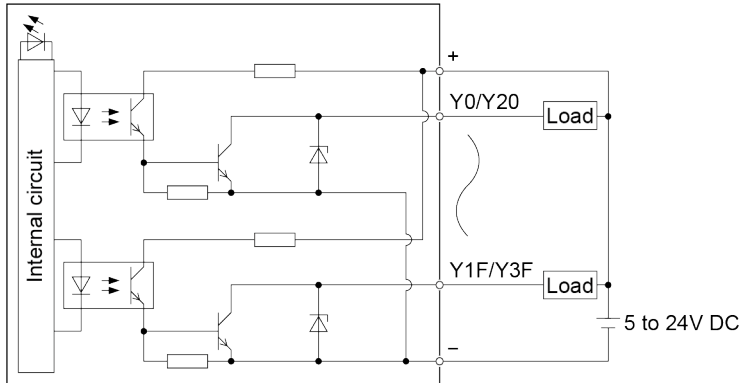

■ Limitations on the load current of the 64-point digital output unit (sink type)

The load current is limited as shown in the following figure depending on the voltage of the external power supply.

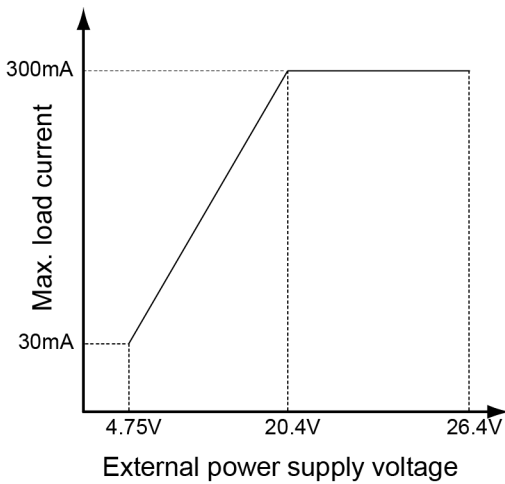

■ Limitations on the number of simultaneous output ON points of the 64-point digital output unit (sink type)

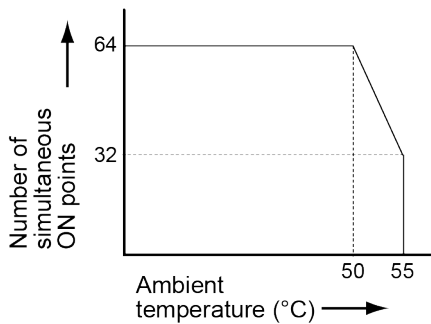

11.3.3 Output Specifications of the 64-point Digital Output Unit (Source Type)

■ **Output specifications (source type)**

Item		Specifications
Insulation method		Optical coupler
Output type		Open collector
Rated load voltage		5 to 24V DC
Allowable load voltage range		4.75 to 26.4V DC
Max. load current		0.3A (20.4 to 26.4V DC), 30mA (4.75V DC)
Common restrictions		3.2 A/common
Max. inrush current		0.6 A
OFF state leakage current		1 μ A or less
ON state max. voltage drop		0.5 V or less
Response time	OFF→ON	0.1 ms or less (Load current: 2 mA or more)
	ON→OFF	0.5 ms or less (Load current: 2 mA or more)
External power supply	Voltage	4.75 to 26.4V DC
	Current	90 mA/common (at 24 V)
Surge absorber		Zener diode
Short-circuit protection		None
Input points per common		32 points/1 common
Operating mode indicator		32-point LED display (Lit when ON, selection using the display selector switch)
External connection method		Connector connection (Compliant with the MIL standard, 40P, two pieces used)

■ **Internal circuit diagram of the 64-point digital output unit (source type)**

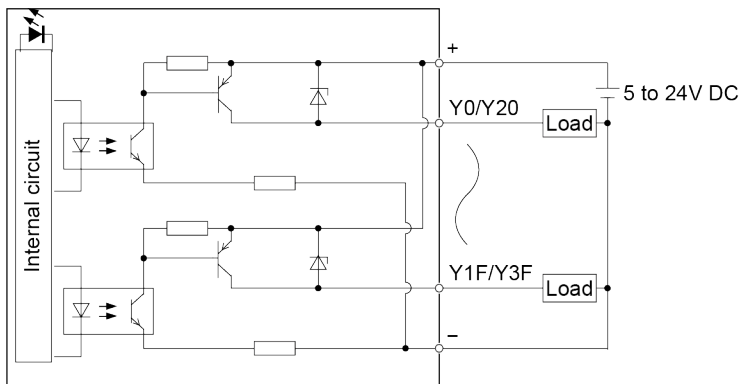

■ **Limitations on the load current of the 64-point digital output unit (source type)**

The load current is limited as shown in the following figure depending on the voltage of the external power supply.

11.3 Specifications of Expansion Units

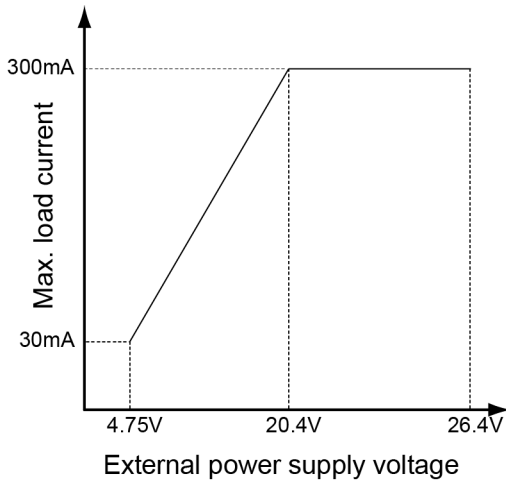

■ **Limitations on the number of simultaneous output ON points of the 64-point digital output unit (source type)**

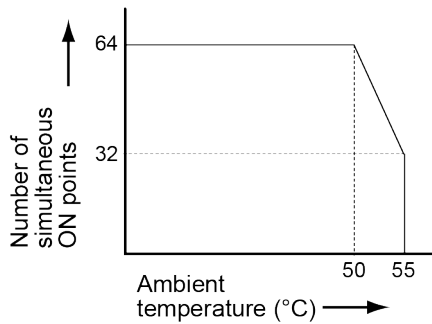

11.3.4 I/O Specifications of the 64-point Digital I/O Unit (Sink Type)

■ **I/O specifications (sink type)**

Item		Specifications
Input specifications	Insulation method	Optical coupler
	Rated input voltage	24 V DC
	Rated input current	Approx. 2.7 mA (at 24 V DC)
	Input impedance	Approx. 6.8 kΩ
	Operating voltage range	20.4 to 26.4 V DC
	Min. ON voltage / Min. ON current	19.2 V / 2.5 mA
	Max. OFF voltage / Max. OFF current	5 V / 1.5 mA
	Response time	OFF→ON 0.2 ms max. (Possible to change by using the input time constant selection function)

Item		Specifications	
	ON→OFF	0.2 ms max. (Possible to change by using the input time constant selection function)	
	Input points per common	32 points/1 common	
Output specifications	Insulation method	Optical coupler	
	Output type	Open collector	
	Rated load voltage	5 to 24 V DC	
	Allowable load voltage range	4.75 to 26.4 V DC	
	Max. load current	0.3 A (20.4 to 26.4 V DC), 30 mA (4.75 V DC)	
	Common restrictions	3.2 A/common	
	Max. inrush current	0.6 A	
	OFF state leakage current	1 μA or less	
	ON state max. voltage drop	0.5 V or less	
	Response time	OFF→ON	0.1 ms or less (Load current: 2 mA or more)
		ON→OFF	0.3 ms or less (Load current: 2 mA or more)
	External power supply	Voltage	4.75 to 26.4 V DC
		Current	70 mA/common (at 24 V)
	Surge absorber	Zener diode	
Short-circuit protection	None		
Input points per common	32 points/1 common		
Operating mode indicator	32-point LED display (Lit when ON, selection using the display selector switch)		
External connection method	Connector connection (Compliant with the MIL standard, 40P, two pieces used)		

■ Internal circuit diagram of the 64-point digital I/O unit (sink type)

Input section (32 points)

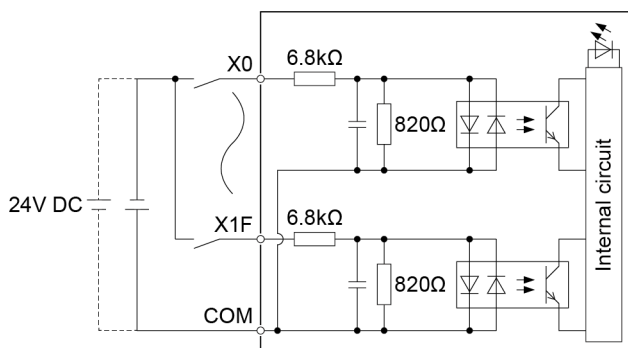

11.3 Specifications of Expansion Units

Output section (32 points)

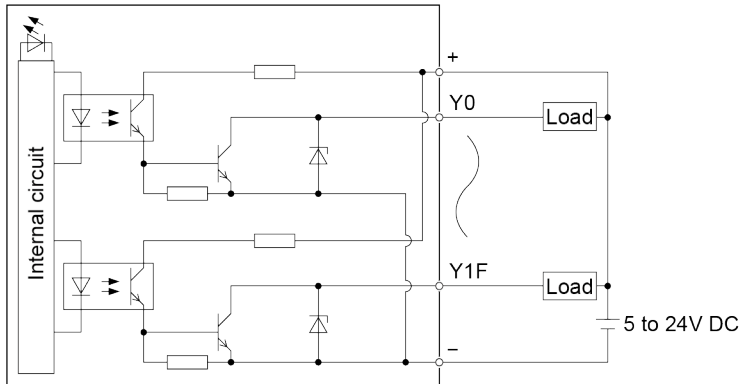

■ Limitations on the load current of the 64-point digital I/O unit (sink type)

The load current is limited as shown in the following figure depending on the voltage of the external power supply.

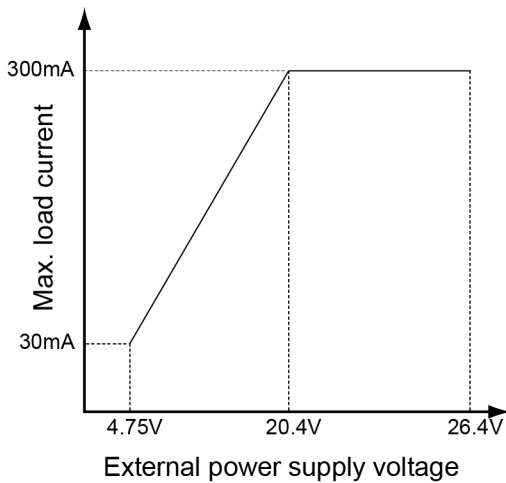

■ Limitations on the number of simultaneous input ON points (max. number of points: 32) of the 64-point digital I/O unit (sink type)

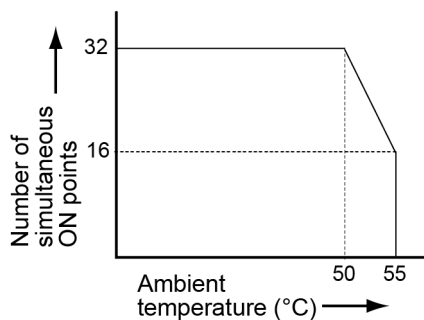

- **Limitations on the number of simultaneous output ON points (max. number of points: 32) of the 64-point digital I/O unit (sink type)**

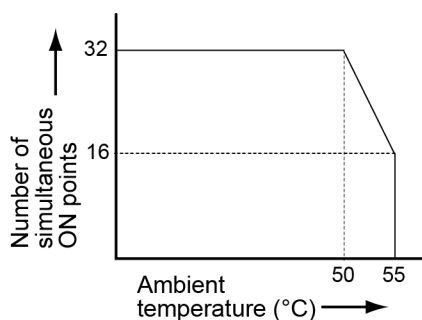

11.3.5 I/O Specifications of the 64-point Digital I/O Unit (Source Type)

- **I/O specifications (source type)**

Item		Specifications	
Input specifications	Insulation method	Optical coupler	
	Rated input voltage	24 V DC	
	Rated input current	Approx. 2.7 mA (at 24 V DC)	
	Input impedance	Approx. 6.8 kΩ	
	Operating voltage range	20.4 to 26.4 V DC	
	Min. ON voltage / Min. ON current	19.2 V / 2.5 mA	
	Max. OFF voltage / Max. OFF current	5V / 1.5 mA	
	Response time	OFF→ON	0.2 ms max. (Possible to change by using the input time constant selection function)
		ON→OFF	0.2 ms max. (Possible to change by using the input time constant selection function)
Input points per common		32 points/1 common	
Output specifications	Insulation method	Optical coupler	
	Output type	Open collector	
	Rated load voltage	5 to 24 V DC	
	Allowable load voltage range	4.75 to 26.4 V DC	
	Max. load current	0.3 A (20.4 to 26.4 V DC), 30 mA (4.75 V DC)	
	Common restrictions	3.2 A/common	
	Max. inrush current	0.6 A	
	OFF state leakage current	1 μA or less	

11.3 Specifications of Expansion Units

Item		Specifications	
	ON state max. voltage drop	0.5 V or less	
	Response time	OFF→ON	0.1 ms or less (Load current: 2 mA or more)
		ON→OFF	0.5 ms or less (Load current: 2 mA or more)
	External power supply	Voltage	4.75 to 26.4 V DC
		Current	90 mA/common (at 24 V)
	Surge absorber	Zener diode	
	Short-circuit protection	None	
Input points per common	32 points/1 common		
Operating mode indicator		32-point LED display (Lit when ON, selection using the display selector switch)	
External connection method		Connector connection (Compliant with the MIL standard, 40P, two pieces used)	

■ Internal circuit diagram of the 64-point digital I/O unit (source type)

Input section (32 points)

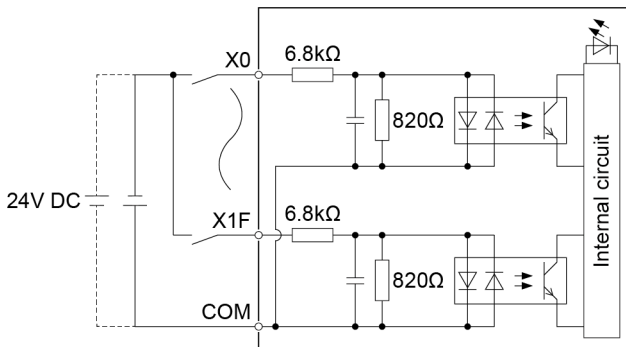

Output section (32 points)

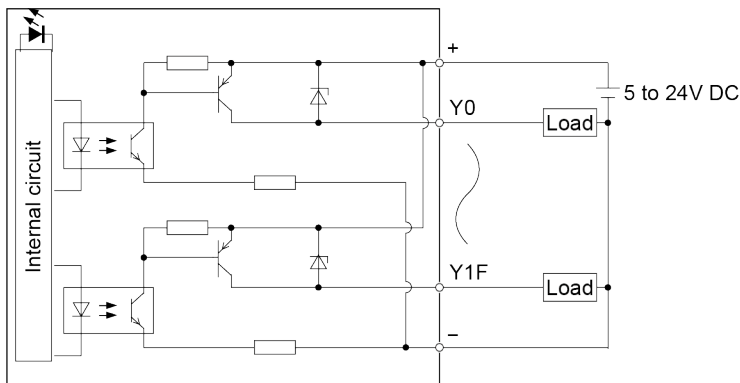

■ Limitations on the load current of the 64-point digital I/O unit (source type)

The load current is limited as shown in the following figure depending on the voltage of the external power supply.

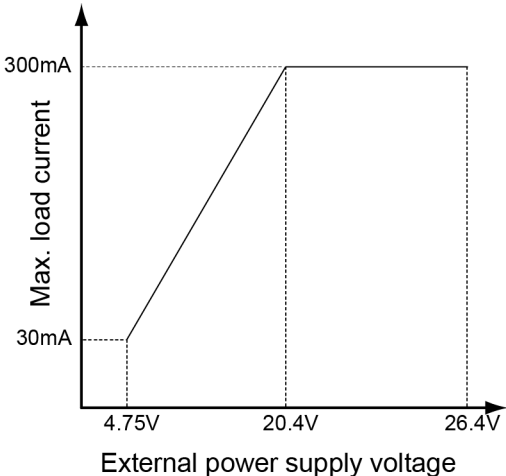

- Limitations on the number of simultaneous input ON points (max. number of points: 32) of the 64-point digital I/O unit (source type)

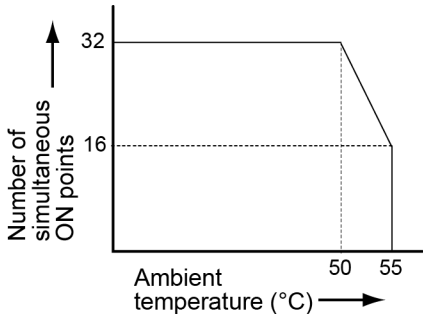

- Limitations on the number of simultaneous output ON points (max. number of points: 32) of the 64-point digital I/O unit (source type)

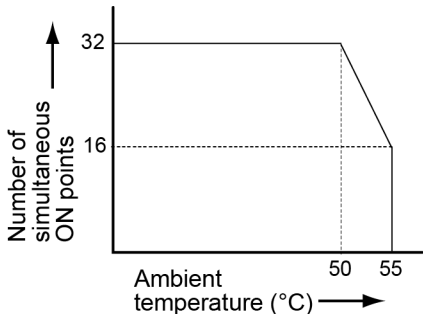

11.3 Specifications of Expansion Units

11.3.6 Input Specifications of the Analog Input Unit

■ Input specifications

Item		Specifications
No. of input points		8 ch
Input range (resolution)	Voltage	-10 to +10 V DC (Resolution: 1/64,000) 0 to +10 V DC (Resolution: 1/32,000) -5 to +5 V DC (Resolution: 1/64,000) 0 to +5 V DC (Resolution: 1/32,000) +1 to +5 V DC (Resolution: 1/25,600) ^(Note 1)
	Current	0 to +20 mA (Resolution: 1/32,000) +4 to +20 mA (Resolution: 1/25,600) ^(Note 1)
Conversion speed		50 μs/ch
Exceeding the rated range		Input is possible up to ± 2% of the input range ^(Note 2)
Total accuracy		±0.2%F.S. or less (at +25°C) ±0.4%F.S. or less (at 0 to +55°C)
Input impedance		Voltage input: Approximately 1 MΩ; current input: Approximately 250 Ω
Absolute max. input		Voltage input: -15 V to +15 V; current input: -30 mA to +30 mA
Insulation method		Between input terminals and internal circuit: Photocoupler and isolated DC/DC converter Between channels: Non-insulated
Execution / Non-execution channel settings		Possible to make non-converted channel settings.
Input range selection		Possible to make settings on a channel-by-channel basis
Average processing	Number of averaging times	Setting range of 2 to 60,000 times
	Time average	Time setting range of 1 to 1,500 ms
	Moving average	Setting range of 2 to 2,000 times
Offset / Gain settings		A desired value within the digital output range can be set for the offset value. Setting range: -3000 to +3000 A desired value within the digital output range can be set for the gain value. Setting range: +9,000 to +11,000 (90% to 110%)
Scale conversion settings		A desired value within the digital output range can be set for the scale conversion setting value. Setting range: -32768 to +32767
Upper limit / lower limit comparison		Output if the value is outside the preset upper limit or lower limit. Setting range: -32768 to +32767
Max. / Min. hold		Holding max. / min. values sampled
Disconnection detection		Disconnection detection is possible for the following ranges. Possible to select auto or manual resetting

11.3 Specifications of Expansion Units

Item	Specifications
	<ul style="list-style-type: none"> • 1 to 5 V range (Detection level: 0.7 V or less) • 4 to 20 mA range (Detection level: 2.8 mA or less.)

(Note 1) The full scale (F.S.) on the accuracy of an analog voltage input range from +1 to +5 V and that of an analog current input range from +4 to +20 mA are 0 to +5 V and 0 to +20 mA, respectively.

(Note 2) If a value that exceeds the input range $\pm 2\%$ is entered, it will be rounded to the input range $\pm 2\%$. However, 0 to 20.4 mA is possible in the 0 to 20 mA range.

11.3.7 Output Specifications of the Analog Output Unit

■ Output specifications

Item	Specifications	
No. of output points	4ch	
Output range (resolution) ^(Note 1)	Voltage	-10 to +10 V DC (Resolution: 1/64,000) 0 to +10 V DC (Resolution: 1/32,000) -5 to +5 V DC (Resolution: 1/64,000) 0 to +5 V DC (Resolution: 1/32,000) +1 to +5 V DC (Resolution: 1/25,600)
	Current	0 to +20 mA (Resolution: 1/32,000) +4 to +20 mA (Resolution: 1/25,600)
Conversion speed	50 μ s/4ch	
Exceeding the rated range	Output is possible up to $\pm 2\%$ of the output range ^(Note 2)	
Total accuracy	$\pm 0.2\%$ F.S. or less (at +25°C) $\pm 0.4\%$ F.S. or less (at 0 to +55°C)	
Output impedance (voltage output)	0.5 Ω or less	
Maximum output current (voltage output)	10 mA	
Output allowable load resistance (current output)	500 Ω or less	
Insulation method	Between output terminals and internal circuit: Photocoupler and isolated DC/DC converter Between channels: Non-insulated	
Conversion execution / non-execution channel settings	Possible to make non-converted channel settings.	
Clipping function	Upper and lower output limits can be set for digital input values. Setting range: -32,640 to +32,640	
Scale conversion settings	A desired value within the digital input range can be set for the scale conversion setting value. Setting range: -32768 to +32767	
Offset / Gain settings	A desired value within the digital input range can be set for the offset value. Setting range: -3,000 to +3,000 A desired value within the digital input range can be set for the gain value.	

11.3 Specifications of Expansion Units

Item	Specifications
	Setting range: +9,000 to +11,000 (90% to 110%)
Analog output hold (in STOP mode)	A desired output value while in STOP mode can be set as a digital value. Setting range: -32640 to +32640

(Note 1) The full scale (F.S.) on the accuracy of an analog voltage output range from +1 to +5 V and that of an analog current output range from +4 to +20 mA are 0 to +5 V and 0 to +20 mA, respectively.

(Note 2) If a value exceeding the output range $\pm 2\%$ is set, the output will be rounded to the output range $\pm 2\%$. However, 0 to 20.4 mA is possible in the 0 to 20 mA range.

11.3.8 Performance Specifications of the Pulse Output Unit

■ Performance specifications

Item	Specifications	
Product No.	AGM1PG04T	AGM1PG04L
Output type	Transistor	Line driver
Number of axes controlled	4 axis, independent	
Position command	Command unit	Pulse unit (for increment or absolute)
	Max. pulse count	Signed 32 bits (-2,147,483,648 to +2,147,483,647 pulses)
Speed command	Command range	1 pps to 500 kpps (can be set in 1 pps.)
		1 pps to 4 Mpps (can be set in 1 pps.)
Acceleration / deceleration command	Acceleration / deceleration method	Linear acceleration / deceleration, S-shaped acceleration / deceleration control
	S-shape pattern	Sine curve, Cubic curve (can be select)
Home return	Home return speed	Speed setting possible (changes return speed and search speed)
	Input signal	Home input, near home input, over limit input (+), over limit input (-)
	Output signal	Deviation counter clear signal
Operation mode	<ul style="list-style-type: none"> ● E-point control (Linear and S-shaped acceleration / deceleration) ● P-point control (Linear and S-shaped acceleration / deceleration) ● Home return (Home search) ● JOG operation^(Note 1) ● JOG positioning ● Pulser input operation^(Note 2) Transfer multiplication ratio (x1, x2, x5, x10, x50, x100, x500, x1000) ● Real-time frequency change function 	
Startup time	0.001ms / 0.005ms / 0.02ms	
Output interface	Output mode	Pulse / Sign, CW / CCW
Feedback counter function ^(Note 2)	Counting range	Signed 32 bits (-2,147,483,648 to +2,147,483,647 pulses)
	Input mode	2-phase input, direction identification input, individual input (transfer multiple available for each mode)

11.3 Specifications of Expansion Units

Item		Specifications	
Product No.		AGM1PG04T	AGM1PG04L
	Max. counting speed	4 MHz (2-phase input) 1 MHz (Direction distinction input and individual input)	
Other functions		<ul style="list-style-type: none"> Built-in over limit input (+) and over limit input (-) Servo ON output incorporated 	

(Note 1) When Linear acceleration/deceleration operation is selected, the target speed can be changed during an operation.

(Note 2) "Pulser input operation" and "Feedback counter" use the same pulse input terminal. Either function of the two can only be used.

■ I/O specifications

- The Pulse Output Unit uses two connectors. The signal pins for two axes are assigned to one connector.
- AX1 and 2, and AX3 and 4 connectors have the completely same pin assignments. Therefore, the same pin number functions the same.
- Between the Transistor type and the Line driver type, the output terminal performance is different. However, the specifications of the input terminal and the power supply terminal are the same for both types.

Transistor output type (AGM1PG04T)

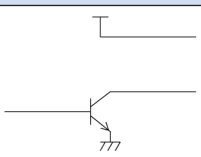
Pin No.		Signal name	Circuit		Specifications
Axis 1 / 3	Axis 2 / 4				
A1	A10	Pulse output A: 5 VDC output		Output	<ul style="list-style-type: none"> Output type: Open collector Operating voltage range: 4.75 to 26.4 V DC Max. load current: 15 mA ON state max. voltage drop: 0.6 V
B1	B10	Pulse output A: Open collector			
A2	A11	Pulse output B: 5 VDC output			
B2	B11	Pulse output B: Open collector			

Line driver output type (AGM1PG04L)

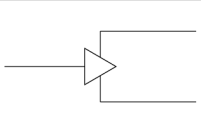

Pin No.		Signal name	Circuit		Specifications
Axis 1 / 3	Axis 2 / 4				
A1	A10	Pulse output A: Line driver (+)		Output	<ul style="list-style-type: none"> Line driver output Equivalent to AM26C31
B1	B10	Pulse output A: Line driver (-)			
A2	A11	Pulse output B: Line driver (+)			
B2	B11	Pulse output B: Line driver (-)			

11.3 Specifications of Expansion Units

Common

Pin No.		Signal name	Circuit		Specifications
Axis 1 / 3	Axis 2 / 4				
A3	A12	Home input: 24 VDC, SELV and LIM (+)		Input	<ul style="list-style-type: none"> Operating voltage range: 21.6 to 26.4 V DC Min. ON voltage / current: 19.2 V DC / 5.5 mA Max. OFF voltage / current: 2.0 V DC / 2.0 mA Input impedance: Approx. 3.9 kΩ Pulse width: 100 μs or more
A4	A13	Home input: 5 VDC, SELV and LIM (+)			
B3	B12	Home input (-)			
B4	B13	COM [24V DC SELV and LIM (+)]		Input	<ul style="list-style-type: none"> Operating voltage range: 21.6 to 26.4 V DC Min. ON voltage / current: <ul style="list-style-type: none"> Near home input (DOG) 19.2 V DC / 5.0 mA Limit input (+) Limit input (-) Positioning control start input (Timing input) 19.2 V DC / 2.6 mA Max. OFF voltage / current: 2.0 V DC / 1.5 mA Input impedance: <ul style="list-style-type: none"> Near home input (DOG) Approx. 3.6 kΩ Limit input (+) Limit input (-) Positioning control start input (Timing input) Approx. 6.8 kΩ Pulse width: 500 μs or more
A5	A14	Near home input (DOG)			
A6	A15	Limit input (+)			
B6	B15	Limit input (-)			
A19	B19	Timing input			

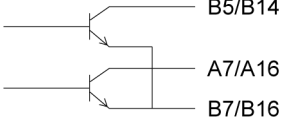
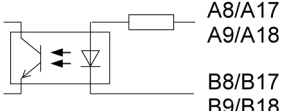
11.3 Specifications of Expansion Units

Pin No.		Signal name	Circuit		Specifications
Axis 1 / 3	Axis 2 / 4				
B5	B14	Servo ON output (+)		Output	<ul style="list-style-type: none"> Output type: Open collector Operating voltage range: 4.75 to 26.4 V DC Max. load current: 10 mA ON state max. voltage drop: 1.0 V
A7	A16	Deviation counter clear (+)			
B7	B16	COM			
A8	A17	Pulse input A (+)		Input	<ul style="list-style-type: none"> Operating voltage range: 3.5 to 5.25 V DC (5 V DC, Line driver specifications) Min. ON voltage / current: 3.0 V DC / 3.2 mA Max. OFF voltage / current: 1.0 V DC / 0.5 mA Input impedance: Approx. 560 Ω Pulse width: 0.5 μs or more (Each phase Max. 1 MHz)
B8	B17	Pulse input A (-)			
A9	A18	Pulse input B (+)			
B9	B18	Pulse input B (-)			
A20		External power supply input: 24 VDC, SELV and LIM (+)		Power supply	<ul style="list-style-type: none"> Supplied power range: 21.4 to 26.4 V DC Consumption current: 90 mA or less
B20		External power supply input: 24 VDC, SELV and LIM (-)			

11.4 Communication Specifications

11.4 Communication Specifications

11.4.1 Specifications of the USB Port

Item	Specifications
Standard	USB2.0 Fullspeed
Connector shape	USB MiniB type

11.4.2 Specifications of the COM Port (RS-232C)

Item	Specifications	
No. of channels	1	
Physical layer	RS-232C, three-wire system (non-isolated)	
Transmission distance	MAX. 15 m	
Communication mode	1:1 communication	
Communication method	Half-duplex transmission	
Transmission line	Multicore shielded wire	
Baud rate	9600 / 19200 / 38400 / 57600 / 115200 bps	
Communication format	Data length	7 bit / 8 bit
	Parity	None, odd, even
	Stop bit	1 bit / 2 bit
	Start code	None
	End code	None
Connector shape	Removable terminal block (5-pin)	

■ Terminal layout of the COM port

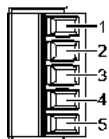

Terminal no.	Signal name	Function
1	SD	Send data
2	RD	Receive data
3	SG	Signal ground
4	N.C.	-
5	N.C.	-

11.4.3 Specifications of the LAN Port

Item		Specifications
Number of ports		2
Communication interface		Ethernet 100BASE-TX / 10BASE-T
Baud rate		100 Mbps / 10 Mbps, automatic negotiation
Max. segment length		100m ^(Note 1)
Max. distance between nodes		100BASE-TX 2 segments
		10BASE-T 5 segments
Communication cable		Shielded twisted pair (TIA/EIA-568B CAT5e or higher)
Communication protocol		TCP/IP UDP
No. of simultaneous connections	LAN1	Maximum 16 units (System connection: 1 unit, user connection: 15 units)
	LAN2	Max. 32 units, general-purpose: 16 units A cycle restriction is applied depending on the total number of connections.
Communication method		Full-duplex / half-duplex communication
TCP/IP protocol		TCP/IP compliant (IPV4)
Functions		<ul style="list-style-type: none"> • Modifying or holding the network settings (IP, Subnet, Gateway) • Possible to set the different networks between Ethernet ports. • Routing between Ethernet ports is not performed.
LED display	LINK	Lit when connection is established with the device on the Ethernet network.
	ACT	Flashes when some communication is performed such as transmitting commands and responses with the devices with established connections.

(Note 1) The standards cite 100m as the maximum, but noise resistance measures such as attaching a ferrite core may be necessary in some cases, depending on the usage environment. Also, it is recommended to position a hub near the control board, and limit the length within 10m.

11.4.4 Specifications of the RTEX Port

Item	Specifications
Baud rate	100 Mbps
Physical layer	100BASE-TX full duplex (IEEE 802.3u)
Cable	Shielded twisted pair (TIA/EIA-568B CAT5e or higher)
Topology	Ring
Insulation method	Pulse transformer
Connector	8-pin RJ45
Maximum cable length	Between nodes: 100 m, total length: 200 m
Communication cycle	500 μ s to 2 ms
Command update period	500 μ s to 4 ms

11.4 Communication Specifications

Item	Specifications
Operation command	Profile position, cyclic position / speed / torque
Number of connectable axes	16 real axes , 20 virtual axes (Total 36 axes)

11.4.5 Specifications of the EtherCAT Port

Item	Specifications
Baud rate	100 Mbps
Physical layer	100BASE-TX full duplex (IEEE 802.3u)
Cable	Shielded twisted pair (TIA/EIA-568B CAT5e or higher)
Topology	Daisy chain (No branching)
Insulation method	Pulse transformer
Connector	8-pin RJ45
Transmission distance	Between nodes: Max. 100 m
Communication cycle	500 us or more
Operation command	Profile position, cyclic position / speed / torque
Number of connectable axes	32 real axes , 20 virtual axes (Total 52 axes)

11.5 Performance Specifications

Item		Specifications
SD (SDHC) memory card	Support media	SD memory card, SDHC memory card Max. 32G
	Supported format standard	Conforms to SD standard.
	Operating mode indicator	LED display (Flashes when accessed.)
	Detection when the cover is open	Available
Memory capacity	Program	16MB
	Variable (non- hold)	16MB
	Variable (hold)	192kB
Clock / calender	Clock accuracy	95 seconds max. per month (at 0°C) 15 seconds max. per month (at +25°C) 130 seconds max. per month (at +55°C)
	Holding time maintained by the internal capacitor when a power failure occurs	14 days or more (at +25°C) ^(Note 1)

(Note 1) The power-ON time of five minutes or longer is required.

11.6 Dimensions

11.6 Dimensions

11.6.1 Dimensions of the GM1 Controller

RTEX-compatible GM1 Controller

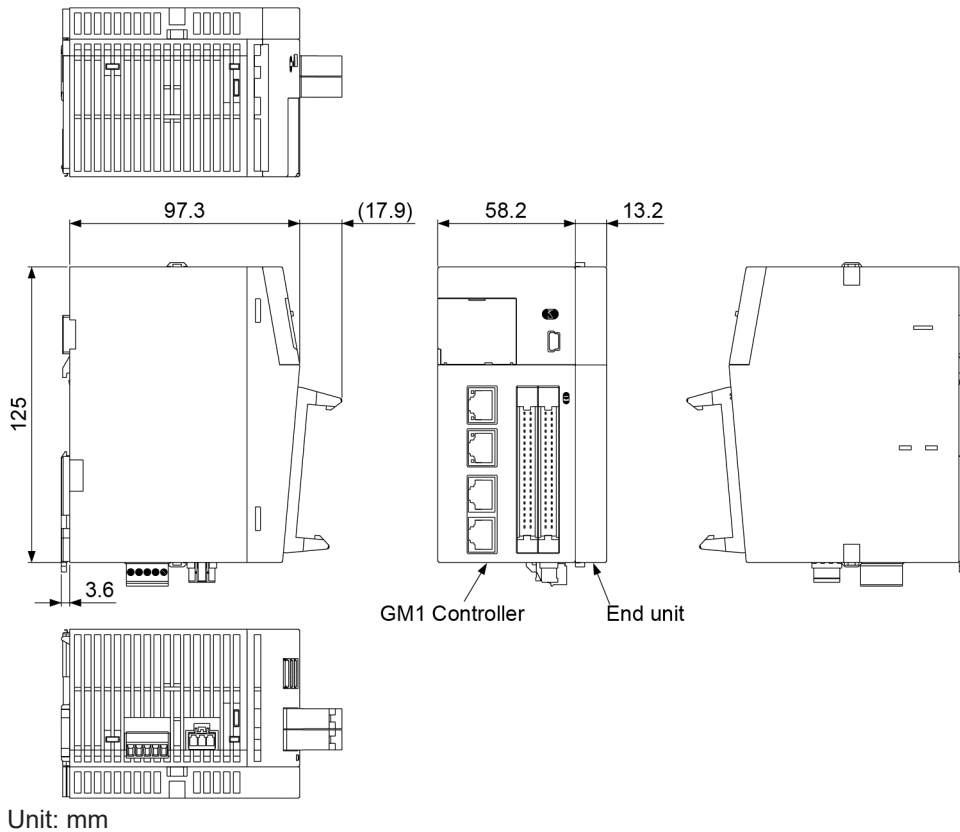

EtherCAT-compatible GM1 Controller

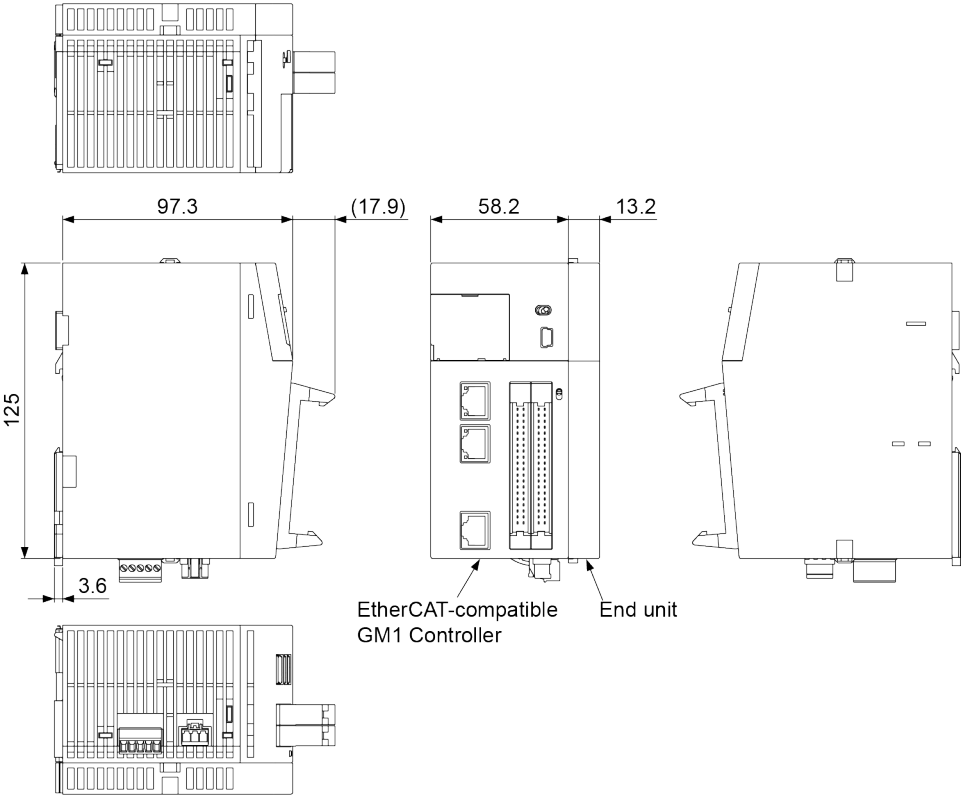

EtherCAT-compatible GM1 Controller End unit

Unit: mm

11.6.2 Dimensions of the GM1 Expansion Unit

Digital I/O unit

11.6 Dimensions

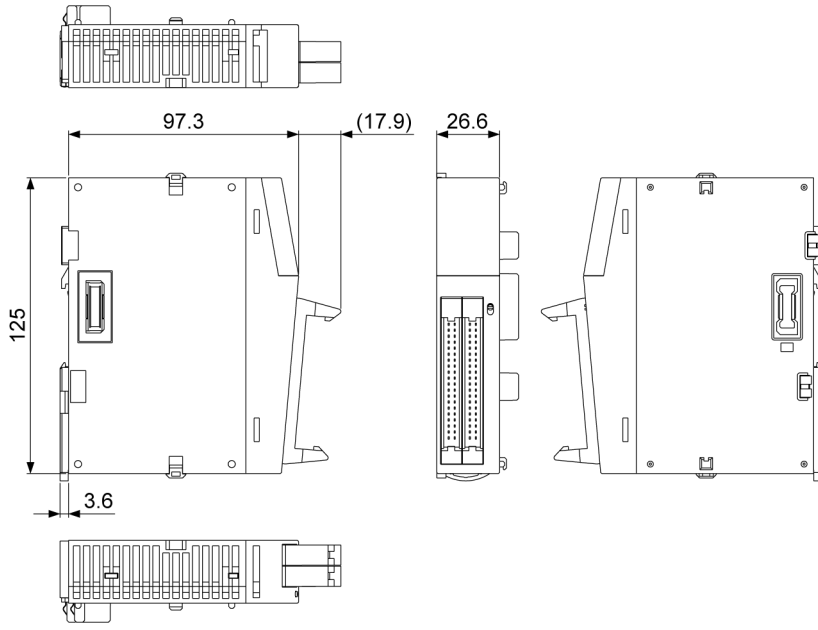

Unit: mm

Analog I/O Unit

Applicable model: AGM1AD8 and AGM1DA4

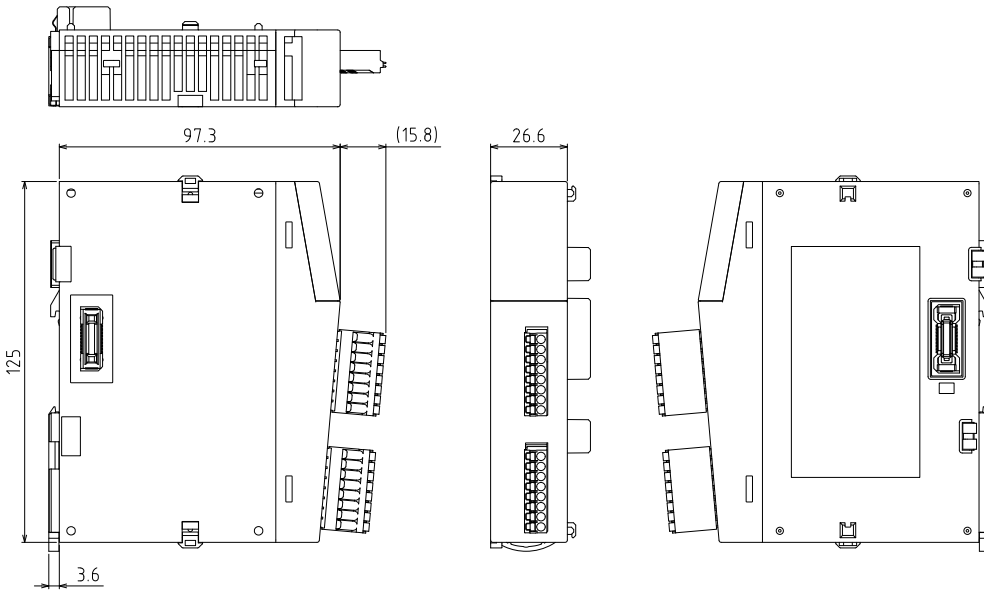

Unit: mm

Pulse Output Unit

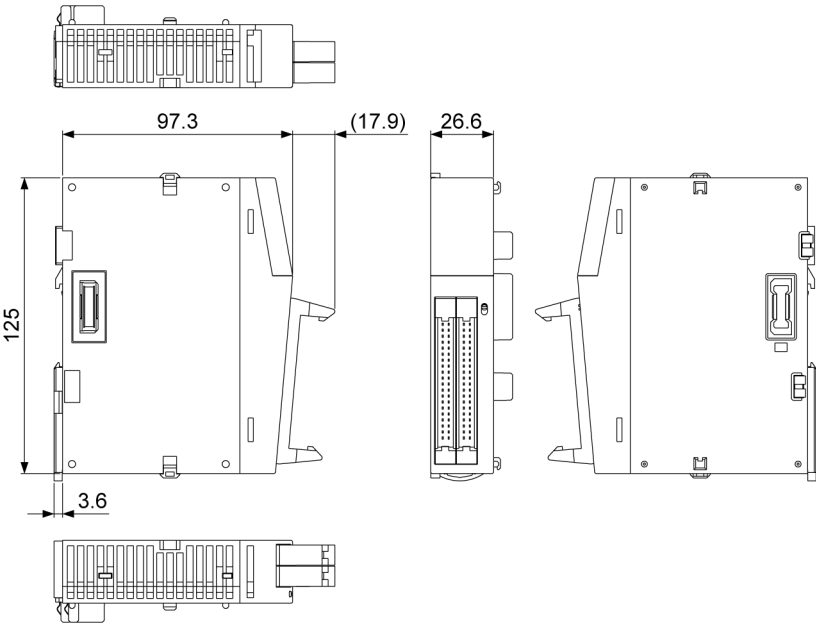

Unit: mm

11.7 Conformance to international standards

11.7 Conformance to international standards

11.7.1 List of conformed standards for motion controllers

conformed standards		Standard number
European EU Standards	EMC	EN 61131-2
	RoHS	EN IEC 63000
UKCA Standards	EMC	EN 61131-2
	RoHS	EN IEC 63000
Radio Waves Act (South Korea) (KC) ^(Note 1)		KN 61131-2

(Note 1) AGM1CSEC16P, AGM1Y64P and AGM1XY64D2P has not obtained the KC standard.

EN :Europaischen Norman

11.7.2 About Radio Waves Act(South Korea)

The motion controller is a Class A device (commercial broadcasting communication device) under Radio Waves Act(South Korea).

Please use this product after recognizing the following precautions.

A 급 기기 (업무용 방송통신기자재)

이 기기는 업무용(A 급) 전자파적합기기로서 판매자 또는 사용자는 이 점을 주의하시기 바라며, 가정외의 지역에서 사용하는 것을 목적으로 합니다.

(대상기종 Motion controller)

[Reference English translation]

Class A equipment (commercial broadcasting communication equipment)

This device is a commercial electromagnetic wave generator (ClassA) and is intended for use outside the home.

Sellers and users should be aware of this.

(Applicable model Motion Controller)

Appendix Warranty / Cautions for Proper Use

Warranty	App-2
Warranty Period	App-2
Warranty Scope	App-2
Cautions for Proper Use	App-3

Warranty

Warranty Period

Warranty period shall be 12 months from the ex-factory date or 18 months from the date of manufacturing.

This Warranty shall be exempted in the following cases,

1. Defects resulting from misuse and/or repair or modification by the customer.
2. Defects resulting from drop of the Product or damage during transportation.
3. Defects resulting from improper usage of the Product beyond the Specifications.
4. Defects resulting from fire, earthquake, lightening, flood, damage from salt, abnormal voltage or other Act of God, or other disaster.
5. Defects resulting from the intrusion of foreign material to the Product, such as water, oil or metallic particles.

Parts exceeding their standard lifetime specified in this document are excluded.

Warranty Scope

Panasonic warrants the replacement of the defected parts of the Product or repair of them when the defects of the Product occur during the Warranty Period, and when the defects are under Panasonic responsibility. This Warranty only covers the Product itself and does not cover any damage incurred by such defects.

Panasonic in accordance with 'Warranty Period' records, in any case, the machine state is poor, and cause damage to your company and the third party, all liability, Panasonic is not responsible.

1. The machines are not assembled in accordance with the instructions or precautions noted in this specification.
2. When the machine does not match the product assembled in the machine.
3. This specification does not depend on your company.
4. When the machine condition is not caused by Panasonic reasons.

Cautions for Proper Use

- Practical considerations for exporting the product or assembly containing the product
When the end user of the product or end use of the product is associated with military affair or weapon, its export may be controlled by the Foreign Exchange and Foreign Trade Control Law. Complete review of the product to be exported and export formalities should be practiced.
- This product is intended to be used with a general industrial product, but not designed or manufactured to be used in a machine or system that may cause personal death when it is failed.
- Installation, wiring, operation, maintenance, etc., of the equipment should be done by qualified and experienced personnel.
- Install a safety equipments or apparatus in your application, when a serious accident or loss of property is expected due to the failure of this product.
- This product is designed for general industrial equipments. Don't use this product under special conditions such as nuclear energy control, aerospace equipments, transportation, medical equipment, various safety equipments or special equipments.
- The wiring condition(earth wire method and cables length and shield cable condition of signal lines) may affect the noise resistance, please confirm the noise resistance of the machine.
- Failure of this product depending on its content, may generate smoke of about one cigarette. Take this into consideration when the application of the machine is clean room related.
- Product overload can cause the goods to fall, please follow the marking.
- Do not use benzine, thinner, alcohol, acidic cleaner and alkaline cleaner because they can discolor or damage the exterior case.
- This product shall be treated as industrial waste when you dispose.
- This product related standards, laws and the user is responsible for matching between machine and components in terms of configuration, dimensions, life expectancy, characteristics, when installing the machine or changing specification of the machine. The user is also responsible for complying with applicable laws and regulations.
- The product will not be guaranteed when it is used outside its specification limits.
- Parts are subject to minor change to improve performance.

(MEMO)

Revision History

The manual code is shown at the bottom of the cover page.

Date of issue	Manual code	Revision details
February 2021	WUME-GM1H-01	First edition
August 2021	WUME-GM1H-02	2nd edition <ul style="list-style-type: none">Added the following models.<ul style="list-style-type: none">EtherCAT-compatible GM1ControllerDigital I/O unit (Source type)Analog I/O UnitPulse Output Unit
March 2022	WUME-GM1H-03	3rd edition <ul style="list-style-type: none">Clerical corrections
April 2022	WUME-GM1H-04	4th edition <ul style="list-style-type: none">Changed the Company name
June 2022	WUME-GM1H-05	5th edition <ul style="list-style-type: none">Clerical correctionsAdded conformance to international standards

(MEMO)

(MEMO)

Please contact

**Industrial Device Business Division,
Panasonic Industry Co., Ltd.**

7-1-1 Morofuku, Daito City, Osaka, 574-0044, Japan
industrial.panasonic.com/ac/e/

© Panasonic Industry Co., Ltd 2021-2022

WUME-GM1H-05