

Panasonic[®]

PROGRAMMABLE CONTROLLERS

FP7 Analog Input Units

User's Manual

Before beginning

Liability and copyright for the hardware

This manual and everything described in it are copyrighted. You may not copy this manual, in whole or part, without written consent of Panasonic Electric Works Europe AG (PEWEU).

PEWEU pursues a policy of continuous improvement of the design and performance of its products. Therefore we reserve the right to change the manual/product without notice. In no event will PEWEU be liable for direct, special, incidental, or consequential damage resulting from any defect in the product or its documentation, even if advised of the possibility of such damages.

We invite your comments on this manual. Please e-mail us at:

techdoc.peweu@eu.panasonic.com.

Please direct support matters and technical questions to your local Panasonic representative.

Limited warranty

If physical defects caused by distribution are found, PEWEU will replace/repair the product free of charge. Exceptions include:

- When physical defects are due to different usage/treatment of the product other than described in the manual.
- When physical defects are due to defective equipment other than the distributed product.
- When physical defects are due to modifications/repairs by someone other than PEWEU.
- When physical defects are due to natural disasters.

Warnings used in this manual

One or more of the following warnings may be used in this documentation:

DANGER



Indicates a hazardous situation which, if not avoided, will result in death or serious injury.

WARNING



Indicates a hazardous situation which, if not avoided, could result in serious or moderate injury.

CAUTION



Indicates a hazardous situation which, if not avoided, could result in minor or moderate injury.

NOTICE

Indicates a property damage message.

Scope of this manual

This manual covers:

- Unit functions
- Restrictions on unit combinations
- Installation, wiring, and operating instructions
- I/O allocation
- Configuration settings
- Time charts
- Conversion characteristics
- Optional settings for averaging, offset and gain adjustment, limit alarm, buffer function, etc.
- Troubleshooting information
- An appendix with:
 - Hardware specifications
 - Unit memory addresses
 - Unit dimensions

Please refer to the FP Series Programming Manual or to the online help of Control FPWIN Pro for information on:

- System instructions
- Special internal flags
- Data registers
- System variables
- Memory area tables
- Programming examples

For documentation on other units used with the FP7, please refer to the hardware manual for that unit.

All manuals can be downloaded from the Panasonic Web site (<http://www.panasonic-electric-works.com>).

Safety measures

Operating environment

After installing the unit, make sure to use it within the range of the general specifications:

- Ambient temperature: 0°C to +55°C
- Ambient humidity: 10%–95% RH (at 25°C, non-condensing)
- Pollution degree: 2
- Do not use the unit in the following environments:
 - Direct sunlight
 - Sudden temperature changes causing condensation
 - Inflammable or corrosive gases
 - Excessive airborne dust, metal particles or salts
 - Benzine, paint thinner, alcohol or other organic solvents, or strong alkaline solutions such as ammonia or caustic soda
 - Vibration, shock, or direct drop of water
 - Influence from power transmission lines, high voltage equipment, power cables, power equipment, radio transmitters, or any other equipment that would generate high switching surges. Maintain at least 100mm of space between these devices and the unit.

Static electricity

Before touching the unit or equipment, always touch some grounded metal to discharge any static electricity you may have generated (especially in dry locations). The discharge of static electricity can damage parts and equipment.

Protection of power supply

- Use a twisted power supply wire.
- Insulate the wiring systems to the CPU, input/output devices, and mechanical power apparatus.
- An insulated power supply with an internal protective circuit should be used (FP power supply). The power supply for the CPU is a non-insulated circuit, so if an incorrect voltage is directly applied, the internal circuit may be damaged or destroyed.

- If using a power supply device without an internal protective circuit, always make sure power is supplied to the unit through a protective element such as a fuse.
- Be sure to supply power to a CPU and an expansion unit from the same power supply, and turn the power on and off simultaneously for both.

Power supply sequence

Make sure the power supply of the CPU turns off before the power supply for input and output. If the power supply for input and output is turned off first, the CPU will detect the input fluctuations and may begin an unexpected operation.

Before turning on the power

When turning on the power for the first time, be sure to take the precautions given below.

- During installation, check that there are no scraps of wiring, particularly conductive fragments, adhering to the unit.
- Verify that the power supply wiring, I/O wiring, and power supply voltage are all correct.
- Sufficiently tighten the installation and terminal screws.
- Set the operation mode selector to PROG mode.

Request concerning program storage

To prevent the accidental loss of programs, the user should consider the following measures:

- Backing up programs: To avoid accidentally losing programs, destroying files, or overwriting the contents of a file, use the backup or export functions of Control FPWIN Pro and store the files in a safe place. Additionally, you can print out the entire project documentation.
- Specifying passwords: The password setting is designed to avoid programs being accidentally overwritten. If the password is forgotten, however, it will be impossible to overwrite the program even if you want to. Also, if a password is forcibly bypassed, the program is deleted. Therefore, please note the password in a safe location.

Table of contents

1. Overview	9
1.1 Features	9
1.2 Unit types	10
1.3 Basic operation	10
1.4 Restrictions on unit combination	11
1.5 Parts and functions	12
2. Wiring	14
2.1 Wiring the terminal block	14
2.2 Connecting the analog inputs	15
2.3 AFP7AD4H	15
2.4 AFP7AD8	17
2.5 Trigger input specifications	19
3. I/O allocation	20
3.1 General	20
3.1.1 Digital values and status flags	21
3.1.2 Control flags	24
4. Operation	27
4.1 Reading of analog input data	27
4.2 Conversion time	28
5. Conversion characteristics	31
5.1 Voltage range	31
5.1.1 -10 to +10V (0.32mV, 1/62500)	31
5.1.2 0 to +5V (0.16mV, 1/31250)	32
5.1.3 1 to +5V (0.16mV, 1/25000)	33
5.2 Current range	33
5.2.1 0 to +20mA (0.64μA, 1/31250)	33
5.2.2 +4 to +20mA (0.64μA, 1/25000)	34
6. Unit configuration	35
6.1 Advanced settings	35
6.2 List of advanced configuration settings	35
6.3 Average processing	38
6.3.1 Count-based average	38
6.3.2 Time-based average	39
6.3.3 Moving average	40
6.4 Offset and gain adjustment	41

6.5	Scale conversion	42
6.6	Limit alarm	43
6.7	Maximum and minimum value hold function	45
6.8	Disconnection detection	48
6.9	Buffer function.....	50
6.9.1	Buffering by trigger flag	53
6.9.2	Buffering by external trigger input	55
6.9.3	Buffering by trigger level.....	57
6.10	Configuration by program	58
7.	Troubleshooting	61
7.1	Failure in reading analog input data	61
7.2	Unstable analog input value	61
7.3	Incorrect digital output values with current input	61
8.	Specifications	62
8.1	General specifications	62
8.2	Performance specifications	62
8.3	I/O allocation.....	65
8.3.1	Digital values and status flags.....	65
8.3.2	Control flags	68
8.4	Unit memory addresses.....	71
8.4.1	Allocation of unit memory addresses	71
8.4.2	Bit settings in unit memory areas	73
8.5	Dimensions	77

Chapter 1

Overview

1.1 Features

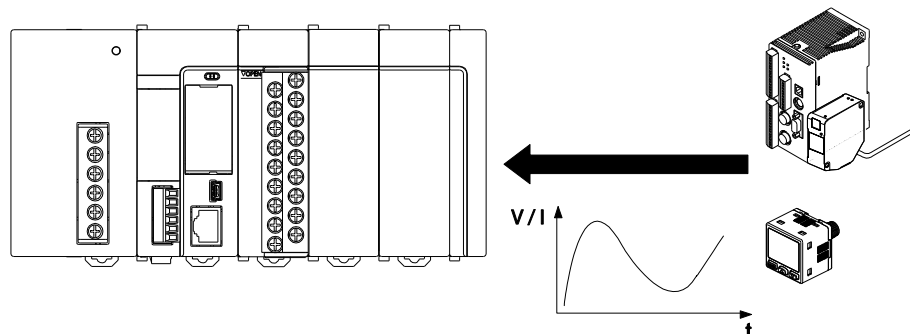

The analog input unit receives analog input data (voltage, current) from analog devices, e.g. analog laser sensors and pressure sensors, and converts them internally into digital values.

- The analog unit AFP7AD4H has 4 channels and AFP7AD8 has 8 channels to receive analog input data.
- To support a variety of connecting equipment, six types of input ranges can be selected.
- The conversion speed is 25 μ s/channel (non-insulated).
- Analog values are converted into digital data with up to 16 bits in a resolution range of 1/25000–1/62500.

Optional functions

Name	Description
Average processing	With average processing, count-based, time-based, or moving averages can be obtained from the analog input values. The average values are stored in the CPU's input area as digital values.
Offset/gain processing	Offset and gain adjustment can be used to correct offset or scaling errors. The offset and gain adjustments are made to the converted data before it is written to the CPU's input area.
Scale conversion	Use scale conversion to set an easy-to-use data range. The digital output values are scaled to values in the specified range between preset minimum and maximum values before they are written to the CPU's input area. This function is convenient if used for unit conversion.
Limit alarm	This function compares the acquired data with the specified upper and lower limits and turns the corresponding flags to TRUE when these limits are exceeded.

Name	Description
Maximum and minimum value hold	This function stores the maximum and minimum values of the acquired data in the unit memory area for each channel.
Disconnection detection	The disconnection detection flag turns to TRUE and the ERROR LED will light if the analog input value does not reach a certain threshold. Valid for 1–5V and 4–20mA ranges only.
Buffer function	The buffer function stores digital output values acquired at a preset cycle in the unit memory. Buffering can be triggered by a trigger flag in the user program, an external trigger input or a value change in analog input.

1.2 Unit types

Name	Description	Product no.
Analog I/O unit	Input unit, 4 channels (high-speed and high-accuracy type)	Voltage input: -10 to +10V, 0 to +5V, 0 to +10V, +1 to +5V
	Input unit, 8 channels (general-purpose type)	Current input: 0 to +20mA, 4 to +20mA
		AFP7AD4H
		AFP7AD8

1.3 Basic operation

The processing of analog input data takes place in three steps:

1. Reception of analog signals

The analog input unit receives analog signals from analog devices, e.g. analog laser sensors or pressure sensors.

2. Analog to digital conversion

The analog input values are converted to digital output values automatically and in sequence.

3. Storage of digital values

A user program is needed to read the digital output values from the CPU's input area (WX).

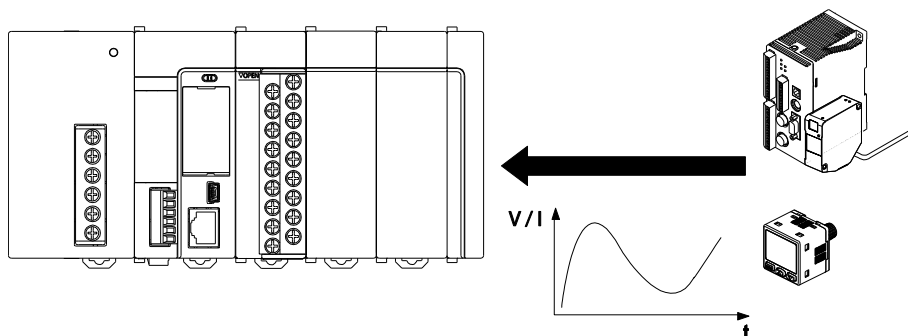

Unit configuration

The unit configuration, which is stored in the unit memory (UM), can be changed via the [Advanced] button in the "I/O map and unit configuration" dialog or by specifying the settings in a user program. The following items can be set:

- Channel-to-channel insulation (AFP7AD4H only)
- Average processing (count-based, time-based, or moving average)
- Scale conversion
- Offset/gain processing
- Maximum and minimum value hold
- Limit alarm
- Disconnection detection
- Buffer function

1.4 Restrictions on unit combination

Current consumption

When designing the system, make sure the total current consumption of all units used together with the analog unit is within the capacity of the power supply. The unit has the following internal current consumption:

Name	Product no.	Current consumption
Analog input unit (high-speed and high-accuracy type)	AFP7AD4H	≤100mA
Analog input unit (general-purpose type)	AFP7AD8	≤85mA

Firmware version

The following CPU firmware versions are required for using the analog input units:

Name	Product no.	Version
Analog input unit (high-speed and high-accuracy type)	AFP7AD4H	Version 1.0 or later
Analog input unit (general-purpose type)	AFP7AD8	Version 3.1 or later

1.5 Parts and functions

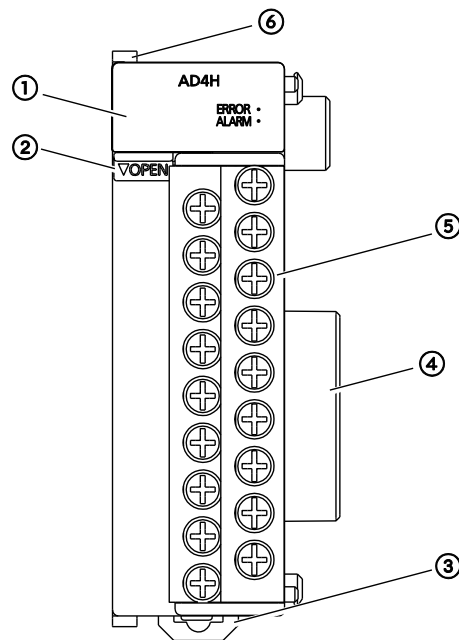

- ① Operation status LEDs – Display the current operation mode or the occurrence of an error.

LED	Color	Description
-	Blue	Lights when the CPU power is on.
ERROR	Red	Lights when the configuration settings are beyond the allowable range or A/D conversion is not possible.
ALARM	Red	Lights when a hardware error occurs.

- ② Terminal block release lever – By lowering this lever, the terminal block can be removed from the unit without disconnecting the wiring. After installation, push in the lock button at the bottom of the unit to lock in the terminal block.
- ③ DIN rail attachment lever – Used for easy attachment to a DIN rail.

- ④ Expansion connector – Connects the unit to the internal circuit of I/O units and intelligent units.
- ⑤ Analog input terminal block – Remove the terminal block to facilitate wiring. Crimp terminals for M3 can be used.
- ⑥ Fixing hook – Used to fix expansion units.

Chapter 2

Wiring

2.1 Wiring the terminal block

Suitable wire

Size	Cross-sectional area [mm ²]	Tightening torque [Nm]
AWG22-14	0.3-2.0	0.5-0.6

Wiring method

Remove the terminal block to facilitate wiring.

Procedure

1. Push down release lever
2. Pull off terminal block

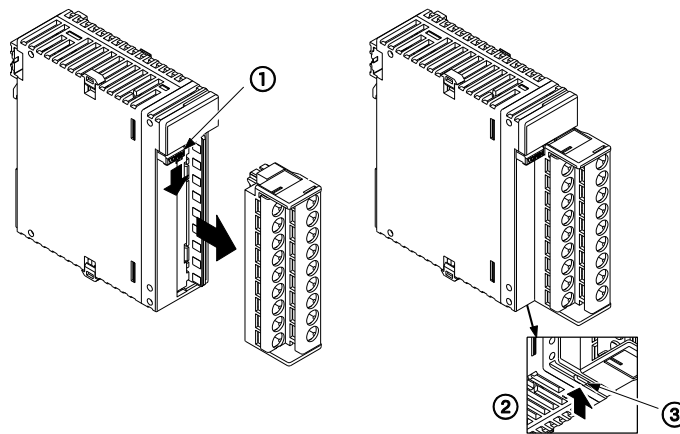

- | | |
|---|------------------------------|
| ① | Terminal block release lever |
| ② | Bottom of unit |
| ③ | Lock button |

Note

To reattach the terminal block, insert it all the way to its original position and press the lock button on the bottom of the unit. Then confirm that the terminal block is securely attached and cannot be removed.

2.2 Connecting the analog inputs

Precautions

- Use double-core twisted-pair shielded wires. We recommend grounding them. However, depending on the conditions of the external noise, it may be better not to ground the shielding.
- Do not place the analog input wires close to power lines or load lines other than PLC wires, and do not bundle them with other wires.

2.3 AFP7AD4H

General

- For the current input, you must connect the V_n and I_n terminals.
- The trigger input terminals (TRIG) are only required when the buffer function is used with external input signals as trigger signals.

Wiring and internal circuit diagram (voltage input)

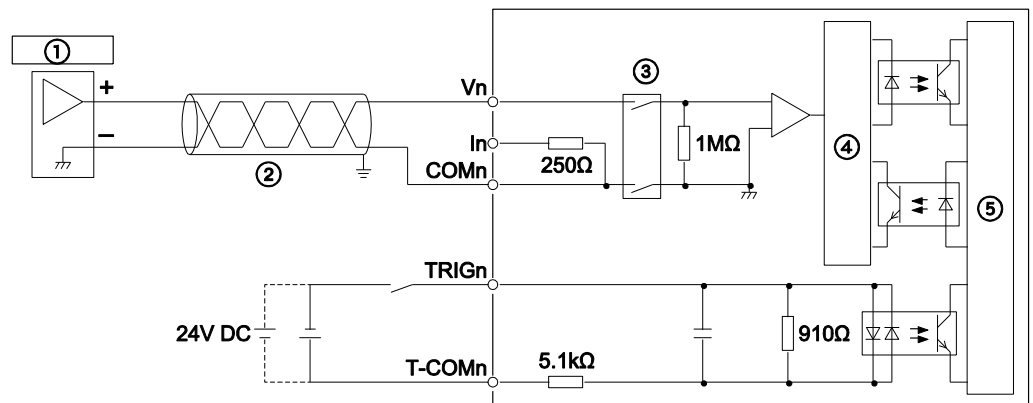

①	Input device
②	Shield
③	PhotoMOS relay
④	A/D conversion circuit
⑤	Internal circuit

Terminal layout (voltage input)

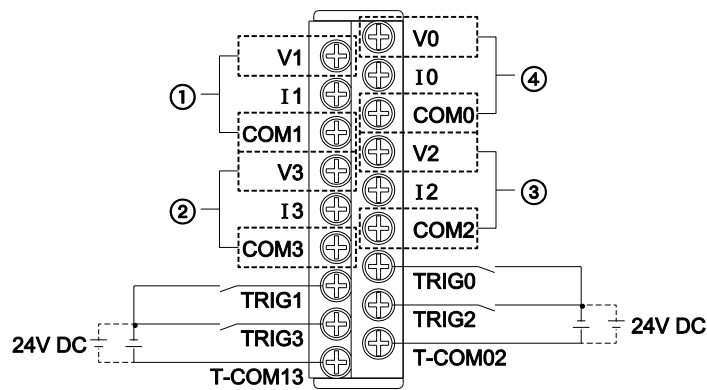

- ① Analog voltage input, channel 1
- ② Analog voltage input, channel 3
- ③ Analog voltage input, channel 2
- ④ Analog voltage input, channel 0

Wiring and internal circuit diagram (current input)

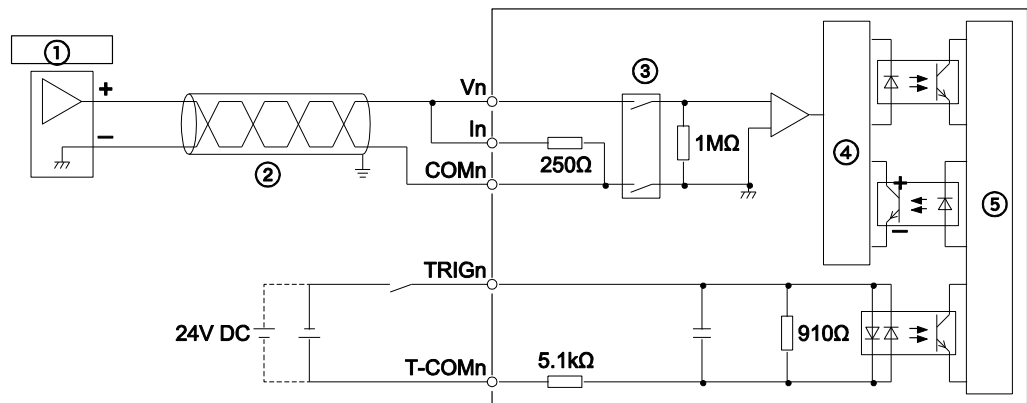

- ① Input device
- ② Shield
- ③ PhotoMOS relay
- ④ A/D conversion circuit
- ⑤ Internal circuit

Note

For the current input, you must connect the V_n and I_n terminals.

Terminal layout (current input)

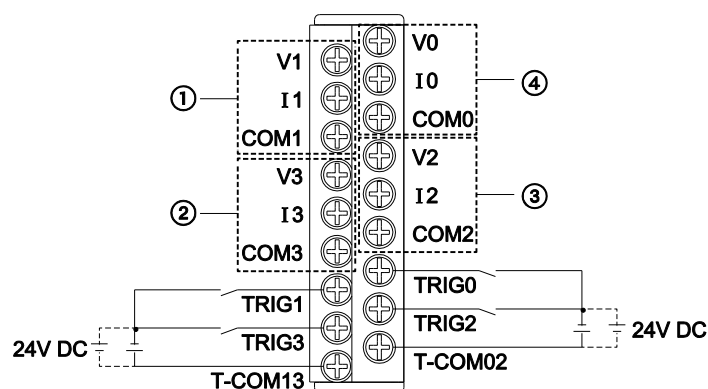

- | | |
|---|---------------------------------|
| ① | Analog current input, channel 1 |
| ② | Analog current input, channel 3 |
| ③ | Analog current input, channel 2 |
| ④ | Analog current input, channel 0 |

Note

TRIG0 to TRIG3 of AFP7AD4H indicate input terminal numbers. Please note that they do not correspond to the analog input channels 0 to 3.

2.4 AFP7AD8

- The voltage and the current input are switched using the range setting in the "Analog unit settings" dialog.
- The trigger input terminals (TRIG) are only required when the buffer function is used with external input signals as trigger signals.

Wiring and internal circuit diagram (voltage and current input)

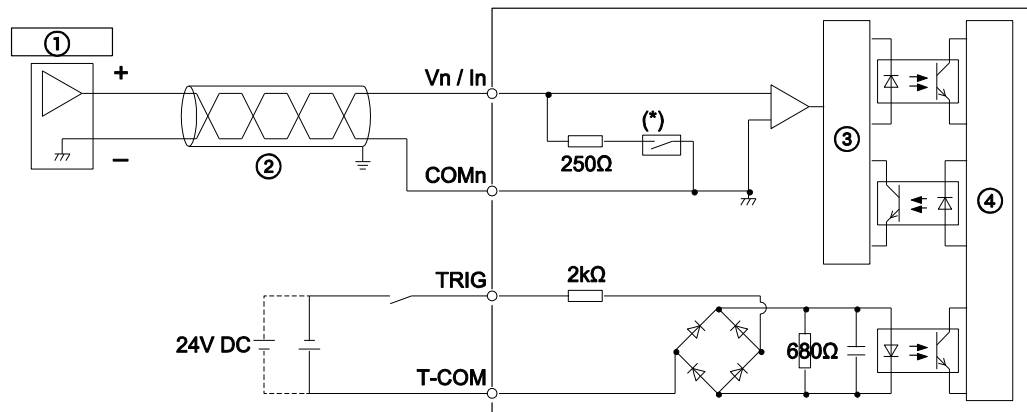

(*) The circuit connection depends on the range setting selected in the "Analog unit settings" dialog (voltage or current input)

- ① Input device
- ② Shield
- ③ A/D conversion circuit
- ④ Internal circuit

Terminal layout (voltage and current input)

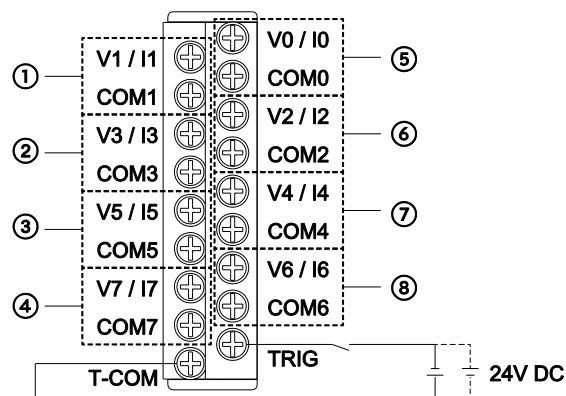

- ① Analog input, channel 1
- ② Analog input, channel 3
- ③ Analog input, channel 5
- ④ Analog input, channel 7
- ⑤ Analog input, channel 0
- ⑥ Analog input, channel 2
- ⑦ Analog input, channel 4
- ⑧ Analog input, channel 6

2.5 Trigger input specifications

The trigger input terminals (TRIG) are only required when the buffer function is used with external input signals as trigger signals.

Description

Item	Description		
	AFP7AD4H	AFP7AD8	
Insulation method	Optical coupler		
Rated input voltage	24V DC		
Rated input current	≈4.5mA (at 24V)	≈12mA (at 24V)	
Input impedance	≈5.1kΩ	≈2kΩ	
Operating voltage range	21.6–26.4V DC		
Min. ON voltage/min. ON current	19.2V/3.5mA		
Max. OFF voltage/max. OFF current	5V/1.5mA		
Response time	FALSE→TRUE	Max. 0.2ms	Max. 0.1ms
	TRUE→FALSE	Max. 0.2ms	Max. 0.1ms
Inputs per common	2	1	
Connection	Terminal block (M3 terminal screws)		

Chapter 3

I/O allocation

3.1 General

Each unit attached to the CPU must be configured in an I/O map which is registered in the CPU. The current I/O map can be displayed in the "I/O map and unit configuration" dialog. It shows the slot numbers and starting word numbers of the CPU and its expansion units. I/O addresses are allocated based on the starting word number.

To display the current I/O map and starting word number of a unit in Control FPWIN Pro, proceed as follows:

Procedure

1. Open project
2. Double-click "PLC" in the navigator
3. Double-click "I/O map and unit configuration"
4. Double-click the desired slot number

Reference

Please refer to the CPU Hardware User's Manual for details on entering and uploading I/O maps.

3.1.1 Digital values and status flags

After A/D conversion, the digital output values are written to the CPU's input area (WX) and processed. Status flags are also allocated to the CPU's inputs.

The I/O addresses in the table show offset addresses. I/O addresses actually allocated are based on the first word number allocated to the unit.

Example: If the first word address is 10, the address numbers for the digital output value and the error flag on channel 0 will be WX10 and X11F, respectively.

Note

- All buffer flags (Buffer function active flag, Buffering in progress flag, Buffering complete flag, Pre-trigger number match flag) are allocated to the inputs of channel 0.
- The default value of the digital output value is 0.
- The default value of the status flags is 16#0.

Channel 0–3

I/O addresses								Name
Channel 0		Channel 1		Channel 2		Channel 3		
WX0	X0–XF	WX2	X20–X2F	WX4	X40–X4F	WX6	X60–X6F	Digital output value (16 bits) ¹⁾
WX1	X10	WX3	X30	WX5	X50	WX7	X70	Disconnection detection flag ²⁾
	X11		X31		X51		X71	High limit alarm flag ³⁾
	X12		X32		X52		X72	Low limit alarm flag ⁴⁾
	X13		X33		X53		X73	Limit alarm active flag ⁵⁾
	X14		X34		X54		X74	Not used
	X15		X35		X55		X75	Maximum/minimum hold active flag ⁶⁾
	X16–X17		X36–X37		X56–X57		X76–X77	Not used
	X18		—		—		—	Buffer function active flag ⁷⁾
	X19		—		—		—	Buffering in progress flag ⁸⁾
	X1A		—		—		—	Buffering complete flag ⁹⁾
	X1B		—		—		—	Pre-trigger number match flag ¹⁰⁾
	X1C–X1E		X3C–X3E		X5C–X5E		X7C–X7E	Not used
	X1F		X3F		X5F		X7F	Error flag ¹¹⁾

Channel 4–7 (AFP7AD8 only)

I/O addresses								Name
Channel 4		Channel 5		Channel 6		Channel 7		
WX8	X80–X8F	WX10	X100–X10F	WX12	X120–X12F	WX14	X140–X14F	Digital output value (16 bits) ¹⁾
WX9	X90	WX11	X110	WX13	X130	WX15	X150	Disconnection detection flag ²⁾
	X91		X111		X131		X151	High limit alarm flag ³⁾
	X92		X112		X132		X152	Low limit alarm flag ⁴⁾
	X93		X113		X133		X153	Limit alarm active flag ⁵⁾
	X94		X114		X134		X154	Not used
	X95		X115		X135		X155	Maximum/minimum hold active flag ⁶⁾
	X96–X97		X116–X117		X136–X137		X156–X157	Not used
	—		—		—		—	Buffer function active flag ⁷⁾
	—		—		—		—	Buffering in progress flag ⁸⁾
	—		—		—		—	Buffering complete flag ⁹⁾
	—		—		—		—	Pre-trigger number match flag ¹⁰⁾
	X9C–X9E		X11C–X311E		X13C–X513E		X15C–X15E	Not used
	X9F		X11F		X13F		X15F	Error flag ¹¹⁾

¹⁾ Digital output value

Memory area for digital values after conversion of the analog input values. If scale conversion has been set, the corresponding scaled values are stored here.

Voltage range	Current range	Digital output value
-10 to +10V	–	-31250 to +31250
0 to +10V or 0 to +5V	–	0 to +31250
+1 to +5V	–	0 to +25000
–	0 to +20mA	0 to +31250
–	+4 to +20mA	0 to +25000

For AFP7AD8 set to voltage input: The digital output value corresponding to an analog input value of about 2V is stored for channels which are not connected to an input.

2) Disconnection detection flag

TRUE when a disconnection has been detected.

FALSE when the connection has been restored.

(Valid for 1–5V and 4–20mA ranges only.)

3) High limit alarm flag

TRUE when the digital output value exceeds the switch-on value for high limit alarm.

4) Low limit alarm flag

TRUE when the digital output value drops below the switch-on value for low limit alarm.

5) Limit alarm active flag

TRUE when the limit alarm function is active.

6) Maximum/minimum hold active flag

TRUE when the maximum and minimum value hold function is active.

7) Buffer function active flag

TRUE when the buffer function is active.

8) Buffering in progress flag

TRUE when buffering starts after the trigger event.

FALSE when the set number of values to be buffered has been captured.

9) Buffering complete flag

TRUE when buffering has completed and the buffer can be accessed for reading.

FALSE when reading of buffered data has completed.

10) Pre-trigger number match flag

TRUE when the set number of values to be buffered before the trigger event has been captured.

FALSE when reading of buffered data has completed.

11) Error flag

TRUE when an error has occurred.

3.1.2 Control flags

Control flags are allocated to the CPU's output area.

The I/O addresses in the table show offset addresses. I/O addresses actually allocated are based on the first word number allocated to the unit.

Example: If the first word number is 10, the address numbers for the disconnection detection execution flag and the error flag reset flag on channel 0 will be Y100 and Y10F, respectively.

Note

All buffer flags (Buffer function control flag, Trigger flag, and Buffer reset flag) are allocated to the outputs of channel 0.

Channel 0–3

I/O addresses								Name
Channel 0		Channel 1		Channel 2		Channel 3		
WY0	Y0	WY1	Y10	WY2	Y20	WY3	Y30	Disconnection detection control flag ¹⁾
	Y1–Y2		Y11–Y12		Y21–Y22		Y31–Y32	Not used
	Y3		Y13		Y23		Y33	Limit alarm control flag ²⁾
	Y4		Y14		Y24		Y34	Not used
	Y5		Y15		Y25		Y35	Maximum/minimum hold control flag ³⁾
	Y6–Y7		Y16–Y17		Y26–Y27		Y36–Y37	Not used
	Y8		—		—		—	Buffer function control flag ⁴⁾
	Y9		—		—		—	Trigger flag ⁵⁾
	YA		—		—		—	Buffer reset flag ⁶⁾
	YB–YE		Y1B–Y1E		Y2B–Y2E		Y3B–Y3E	Not used
	YF		Y1F		Y2F		Y3F	Error reset flag ⁷⁾

Channel 4–7 (AFP7AD8 only)

I/O addresses								Name
Channel 4		Channel 5		Channel 6		Channel 7		
WY4	Y40	WY5	Y50	WY6	Y60	WY7	Y70	Disconnection detection control flag ¹⁾
	Y41–Y42		Y51–Y52		Y61–Y62		Y71–Y72	Not used
	Y43		Y53		Y63		Y73	Limit alarm control flag ²⁾
	Y44		Y54		Y64		Y74	Not used
	Y45		Y55		Y65		Y75	Maximum/minimum hold control flag ³⁾
	Y46–Y47		Y56–Y57		Y66–Y67		Y76–Y77	Not used
	–		–		–		–	Buffer function control flag ⁴⁾
	–		–		–		–	Trigger flag ⁵⁾
	–		–		–		–	Buffer reset flag ⁶⁾
	Y4B–Y4E		Y5B–Y5E		Y6B–Y6E		Y7B–Y7E	Not used
	Y4F		Y5F		Y6F		Y7F	Error reset flag ⁷⁾

¹⁾ Disconnection detection control flag

TRUE to execute the disconnection detection function.

FALSE to turn the disconnection detection flag (Xn0) to FALSE.

(Valid for 1–5V and 4–20mA ranges only.)

²⁾ Limit alarm control flag

TRUE to execute the limit alarm function.

FALSE to turn the high limit alarm flag (Xn1) and low limit alarm flag (Xn2) to FALSE.

³⁾ Maximum/minimum hold control flag

TRUE to execute the maximum/minimum hold function.

FALSE to turn the maximum/minimum hold active flag (Xn5) to FALSE.

⁴⁾ Buffer function control flag

TRUE to enable trigger acceptance.

FALSE to initialize the internal status.

5) **Trigger flag**

TRUE to start buffering.

6) **Buffer reset flag**

TRUE for one scan when reading of the buffer has been completed. Clears the buffer and enables trigger acceptance.

7) **Error reset flag**

TRUE to reset the error flag (XnF).

Chapter 4

Operation

4.1 Reading of analog input data

The processing of analog input data takes place in three steps:

1. Reception of analog signals

The analog input unit receives analog signals from analog devices, e.g. analog laser sensors or pressure sensors.

2. Analog to digital conversion

The analog input values are converted to digital output values automatically and in sequence.

3. Storage of digital values

A user program is needed to read the digital output values from the CPU's input area (WX).

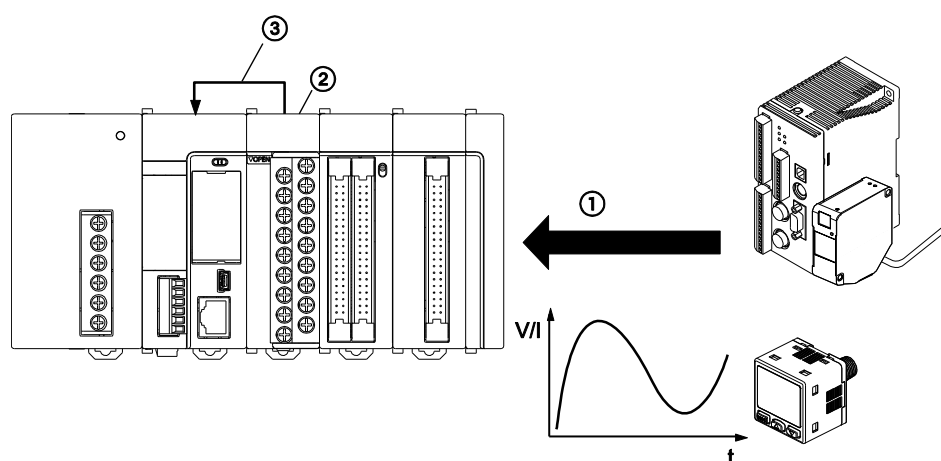

- | | |
|---|----------------------|
| ① | Analog signal |
| ② | A/D conversion |
| ③ | Digital output value |

Sample program

The digital output values from the analog input unit are stored in the CPU's memory areas DIXWX0, DIXWX2, DIXWX4, and DIXWX6. They are read and stored by channel in four different variables.

POU Header

	Class	Identifier	Type	Initial
0	VAR_CONSTANT	iSlotNumber	INT	0
1	VAR	bReadInputValues	BOOL	FALSE
2	VAR	iInputChannel0	INT	0
3	VAR	iInputChannel1	INT	0
4	VAR	iInputChannel2	INT	0
5	VAR	iInputChannel3	INT	0

LD Body

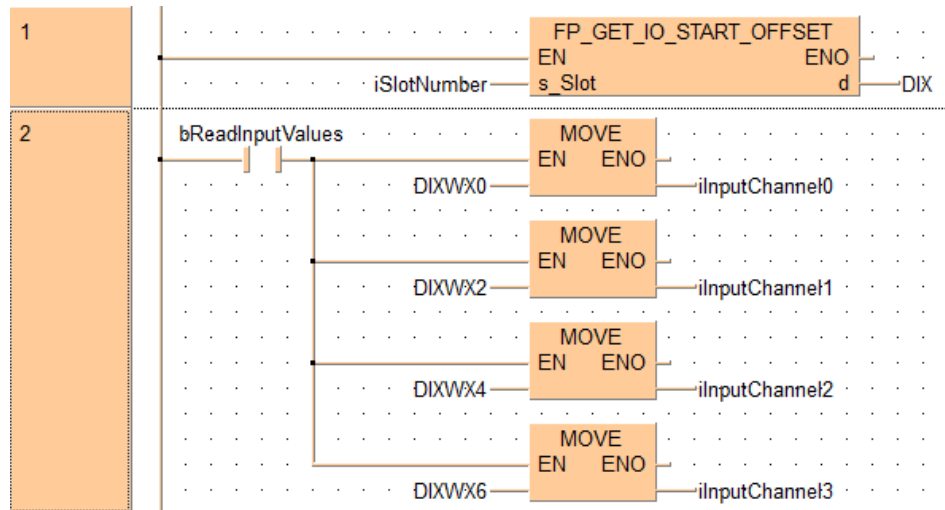

4.2 Conversion time

Conversion time varies with the selected configuration settings.

Channel-to-channel insulation

Insulated: 5ms/channel

Non-insulated: 25µs/channel

The analog input channels are insulated by switching the corresponding PhotoMOS relays when data is being converted. For non-insulated channels, the PhotoMOS relays are always TRUE and the commons will be shared. Therefore, A/D conversion will become faster if "Non-insulated" is selected for "Channel-to-channel insulation".

For AFP7AD8, only the "Non-insulated" setting is available.

Conversion processing

To speed up conversion, disable "Conversion processing" for all unused channels.

Example

For AFP7AD4H:

Conversion processing is enabled for 4 channels:

- Order of conversion: channel 0→channel 1→channel 2→channel 3→channel 0→channel 1→channel 2→channel 3→...
- 1 cycle = 4 channels × 25μs = 100μs for non-insulated channels

Conversion processing is enabled for 2 channels:

- Order of conversion: channel 0→channel 1→channel 0→channel 1→...
- 1 cycle = 2 channels × 25μs = 50μs for non-insulated channels (The conversion time for the disabled channels 2 and 3 is saved.)

Time chart of A/D conversion

The digital output values from the analog unit are read by the CPU program at the CPU's I/O refresh time. A/D conversion in the analog unit and the CPU's processing cycles are not synchronized. Therefore, the latest digital output value will only be written into the CPU's operation memory when an I/O refresh is performed.

Example

Conversion processing is enabled for 4 channels:

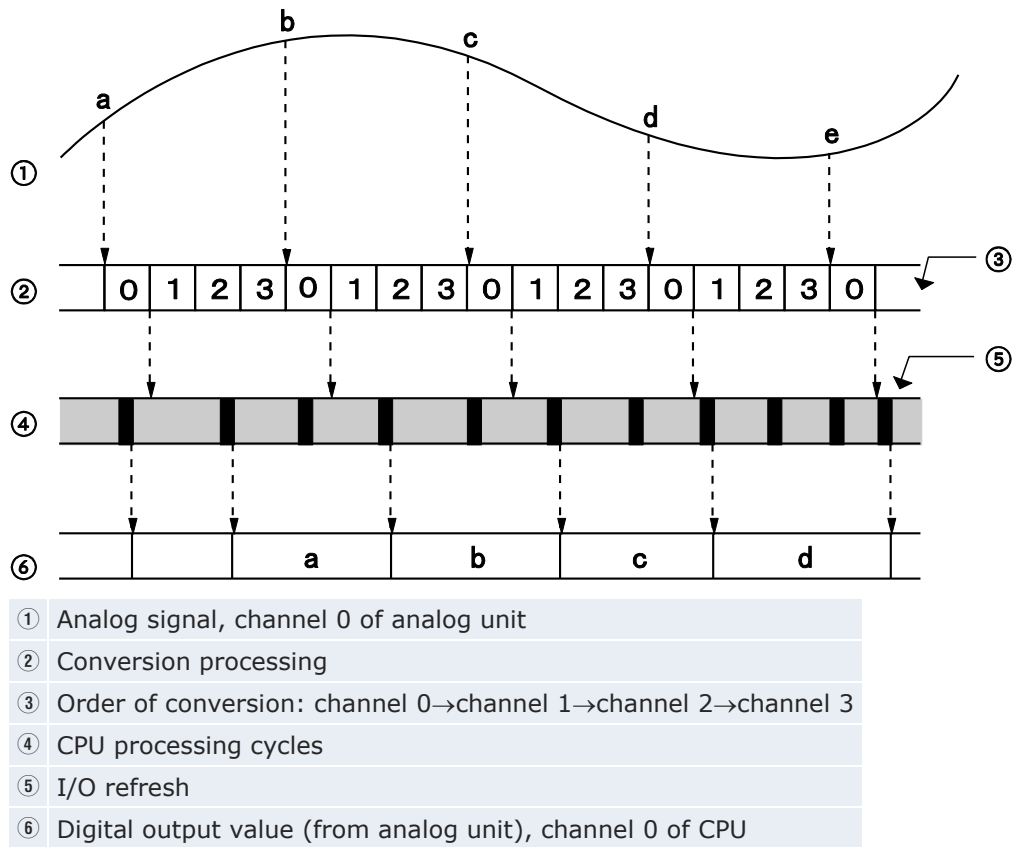

Example

Conversion processing is enabled for 1 channel:

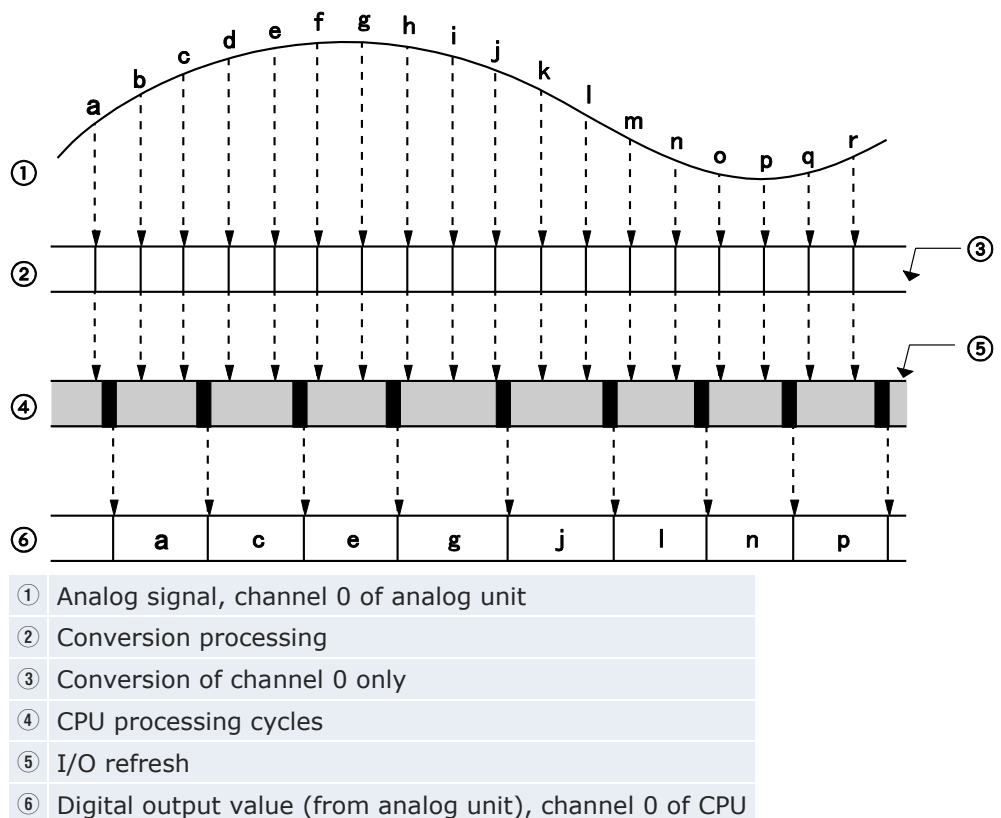

Chapter 5

Conversion characteristics

5.1 Voltage range

5.1.1 -10 to +10V (0.32mV, 1/62500)

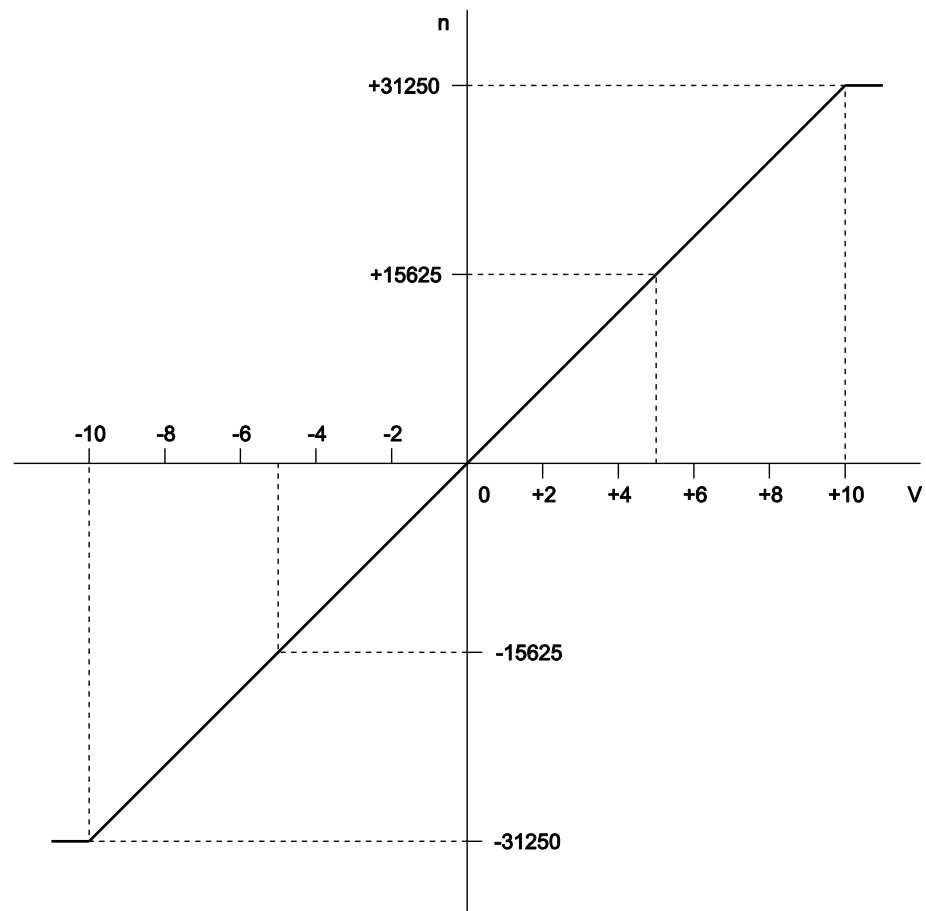

Analog input value (V)	Digital output value (n)
+10	+31250
+8	+25000
+6	+18750
+4	+12500
+2	+6250
0	0
-2	-6250
-4	-12500
-6	-18750
-8	-25000
-10	-31250

When exceeding the rated range

Analog input value (V)	Digital output value
$\geq +10V$	+31250
$\leq -10V$	-31250

5.1.2 0 to +5V (0.16mV, 1/31250)

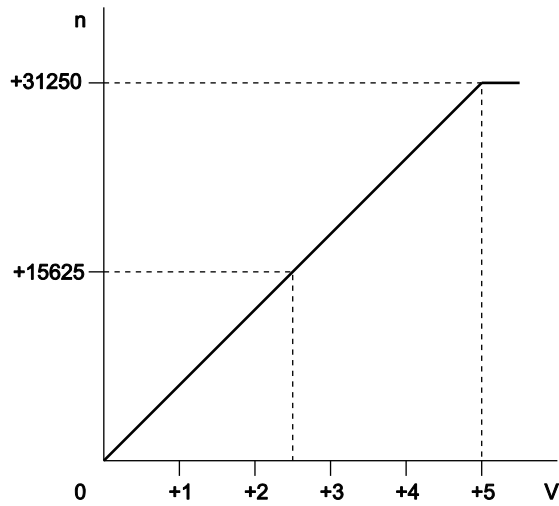

Analog input value (V)	Digital output value (n)
+5	+31250
+4	+25000
+3	+18750
+2	+12500
+1	+6250
0	0

When exceeding the rated range

Analog input value (V)	Digital output value
$\geq +5V$	+31250
$\leq 0V$	0

5.1.3 1 to +5V (0.16mV, 1/25000)

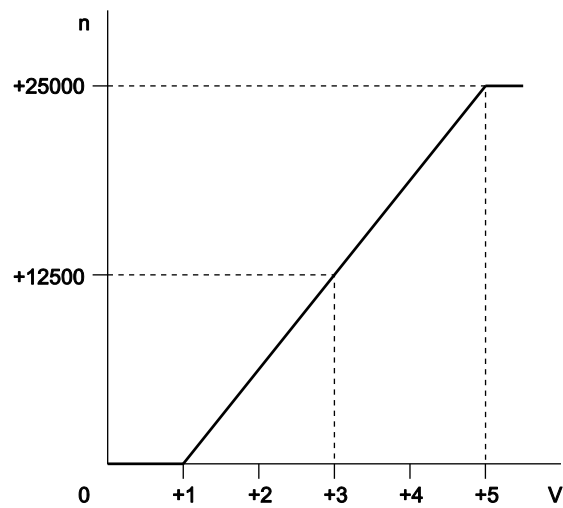

Analog input value (V)	Digital output value (n)
+5	+25000
+4	+18750
+3	+12500
+2	+6250
+1	0

When exceeding the rated range

Analog input value (V)	Digital output value
$\geq +5V$	+25000
$\leq 1V$	0

5.2 Current range

5.2.1 0 to +20mA (0.64 μ A, 1/31250)

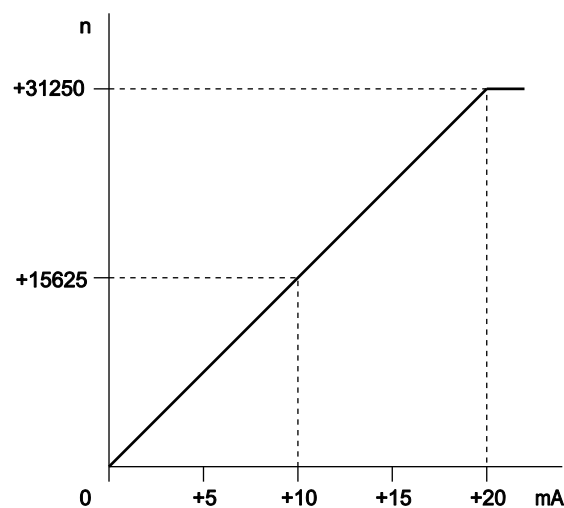

Analog input value (mA)	Digital output value (n)
+20	+31250
+16	+25000
+12	+18750
+8	+12500
+4	+6250
0	0

When exceeding the rated range

Analog input value (mA)	Digital output value
$\geq +20\text{mA}$	+31250
$\leq 0\text{mA}$	0

5.2.2 +4 to +20mA (0.64 μA , 1/25000)

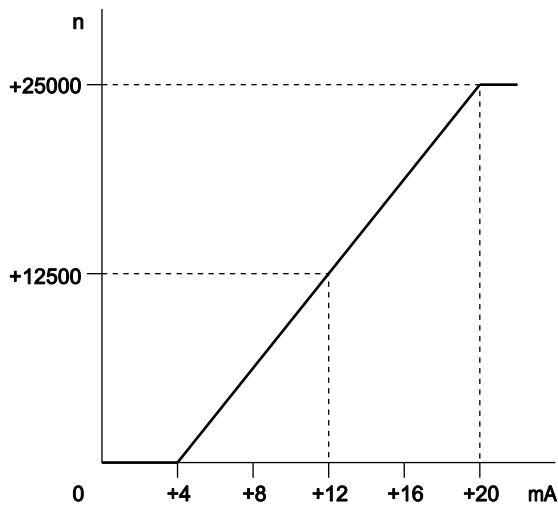

Analog input value (mA)	Digital output value (n)
+20	+25000
+16	+18750
+12	+12500
+8	+6250
+4	0

When exceeding the rated range

Analog input value (mA)	Digital output value
$\geq +20\text{mA}$	+25000
$\leq +4\text{mA}$	0

Chapter 6

Unit configuration

6.1 Advanced settings

After the unit has been entered in the I/O map, it can be configured in Control FPWIN Pro.

Procedure

1. Open project
2. Double-click "PLC" in the navigator
3. Double-click "I/O map and unit configuration"
4. Double-click the desired slot number
5. [Advanced]
6. Make the desired settings
7. [OK]

The settings will become effective when the project is downloaded to the PLC.

6.2 List of advanced configuration settings

AFP7AD4H

General/Buffer function (common to all channels):

Item name	Data	Default setting
Channel-to-channel insulation	Non-insulated/Insulated	Non-insulated
Buffer function	Disable/Enable	Disable
Trigger type	Trigger flag/Trigger input rising edge/Trigger input falling edge/Trigger level rising edge/Trigger level falling edge	Trigger flag
Trigger input	Unused/TRIG0/TRIG1/TRIG2/TRIG3	Unused
Level triggering channel	Unused/Channel 0/Channel 1/Channel 2/Channel 3	Unused
Number of buffered values	1-10000	1000
Number of pre-trigger values	0-9999	0

Item name	Data	Default setting
Sampling cycle	1–30000	1
Trigger level	-31250 to +31250	0

Channel 0-3 (settings per channel)

Item name	Data	Default setting
Conversion processing	Enable/Disable	Enable
Range setting	-10V..10V/0V..10V/0V..5V/1V..5V/0mA. .20mA/4mA..20mA	-10V..10V
Average processing	Disable/Count-based average/Time-based average/Moving average	Disable
Average count or time period	Count-based average: 2–60000 counts Time-based average (Non-insulated): 1–1500ms Time-based average (Insulated): 200–60000ms Moving average: 2–2000 counts	200
Offset/gain processing	Disable/Enable	Disable
Offset value	-3000 to +3000	0
Gain value	+9000 to +11000	10000
Scale conversion	Disable/Enable	Disable
Upper limit of scale	-30000 to +30000	10000
Lower limit of scale	-30000 to +30000	0
Limit alarm	Disable/Enable	Disable
High limit alarm switch-on value	-31250 to +31250	1000
High limit alarm switch-off value	-31250 to +31250	1000
Low limit alarm switch-on value	-31250 to +31250	0
Low limit alarm switch-off value	-31250 to +31250	0
Maximum and minimum value hold	Disable/Enable	Disable
Disconnection detection	Disable/Enable	Disable
Disconnection detection flag reset	Automatic/Manual	Automatic

AFP7AD8

Buffer function (common to all channels):

Item name	Data	Default setting
Buffer function	Disable/Enable	Disable
Trigger type	Trigger flag/Trigger input rising edge/Trigger input falling edge/Trigger level rising edge/Trigger level falling edge	Trigger flag
Trigger input	Unused/TRIG0/TRIG1/TRIG2/TRIG3	Unused
Level triggering channel	Unused/Channel 0/Channel 1/Channel 2/Channel 3/Channel 4/Channel 5/Channel 6/Channel 7	Unused
Number of buffered values	1-10000	1000
Number of pre-trigger values	0-9999	0
Sampling cycle	1-30000	1
Trigger level	-31250 to +31250	0

Channel 0-3 (settings per channel)

Item name	Data	Default setting
Conversion processing	Enable/Disable	Enable
Range setting	-10V..+10V/0V..10V/0V..5V/1V..5V/0mA..20mA/4mA..20mA	-10V..10V
Average processing	Disable/Count-based average/Time-based average/Moving average	Disable
Average count or time period	Count-based average: 2-60000 counts Time-based average: 1-1500ms Moving average: 2-2000 counts	200
Offset/gain processing	Disable/Enable	Disable
Offset value	-3000 to +3000	0
Gain value	+9000 to +11000	10000
Scale conversion	Disable/Enable	Disable
Upper limit of scale	-30000 to +30000	10000
Lower limit of scale	-30000 to +30000	0
Limit alarm	Disable/Enable	Disable
High limit alarm switch-on value	-31250 to +31250	1000
High limit alarm switch-off value	-31250 to +31250	1000
Low limit alarm switch-on value	-31250 to +31250	0
Low limit alarm switch-off value	-31250 to +31250	0

Item name	Data	Default setting
Maximum and minimum value hold	Disable/Enable	Disable
Disconnection detection	Disable/Enable	Disable
Disconnection detection flag reset	Automatic/Manual	Automatic

6.3 Average processing

With average processing, count-based, time-based, or moving averages can be obtained from the analog input values. The average values are stored in the CPU's input area as digital values.

6.3.1 Count-based average

If count-based average has been selected, a set number of analog input values are averaged and the average values are stored as digital values. If the number of analog input values acquired is less than the set number, the converted digital values will be stored without averaging.

Processing of analog measurement values

Example

The number of counts has been set to 5.

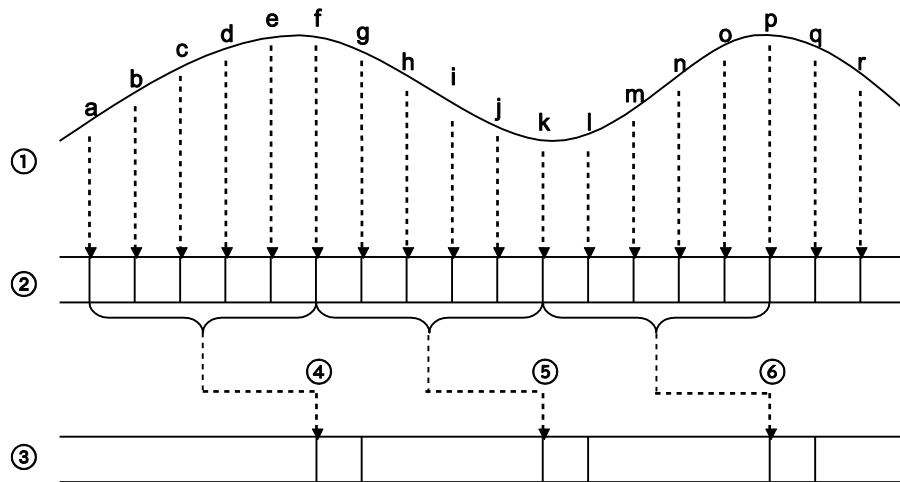

- ① Analog signal
- ② Analog input processing
- ③ Analog input values
- ④ Average of a-e
- ⑤ Average of f-j
- ⑥ Average of k-o

Configuration

Name	Default	Setting range
Average processing	Disable	Select "Count-based average"
Average count or time period	200	200–60000ms counts (specified with an unsigned integer)

6.3.2 Time-based average

If time-based average has been selected, the analog measurement values acquired during a set period of time are averaged and stored as digital values.

Processing of analog measurement values

Example

The time period has been set to 5ms.

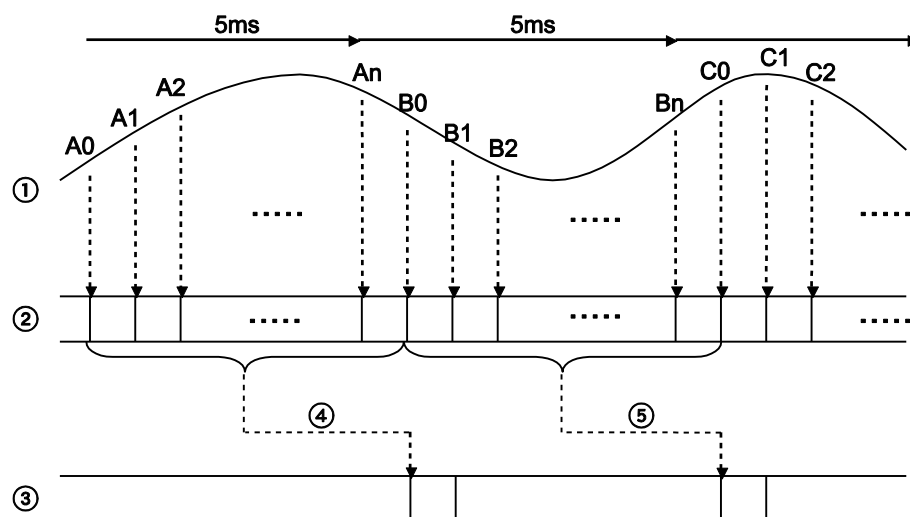

- ① Analog signal
- ② Analog input processing
- ③ Analog input values
- ④ Average of A0–An
- ⑤ Average of B0–Bn

Configuration

Name	Default	Setting range
Average processing	Disable	Select "Time-based average"
Average count or time period	200	Time (non-insulated): 1–1500ms Time (insulated): 200–60000ms (FP7AD4H only) (specified with an unsigned integer)

6.3.3 Moving average

If moving average has been selected, a series of averages are calculated of a shifting number of analog input values and stored as digital values.

Processing of analog measurement values

Example

The number of counts has been set to 15.

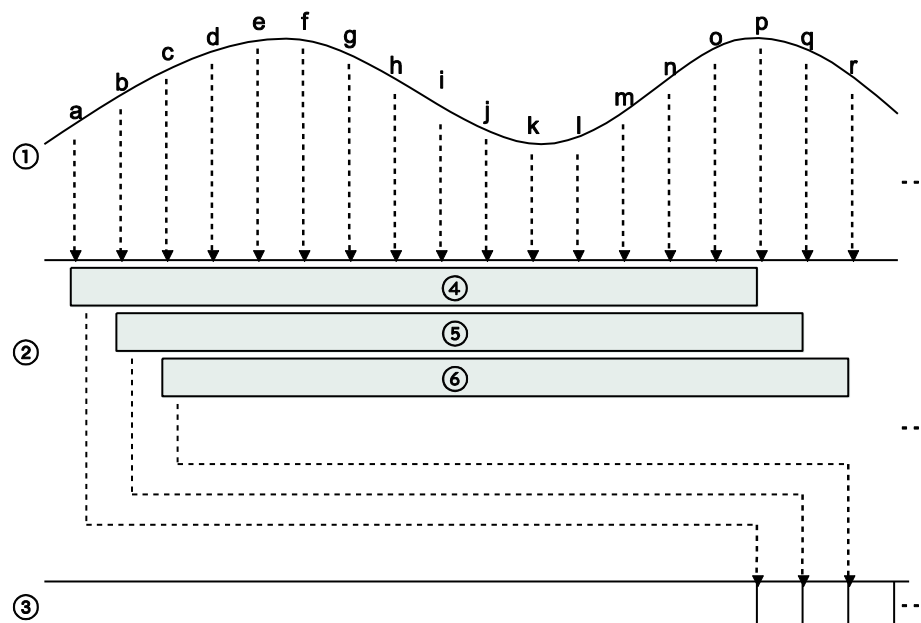

- ① Analog signal
- ② Analog input processing
- ③ Analog input values
- ④ Average of a–o
- ⑤ Average of b–p
- ⑥ Average of c–q

Configuration

Name	Default	Setting range
Average processing	Disable	Select "Moving average"
Average count or time period	200	200–2000 counts (specified with an unsigned integer)

6.4 Offset and gain adjustment

Offset and gain adjustment can be used to correct offset or scaling errors. The offset and gain adjustments are made to the converted data before it is written to the CPU's input area.

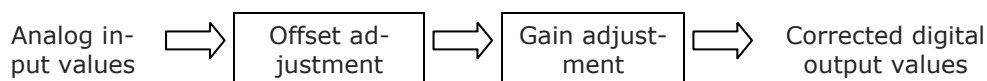

- The offset adjustment (zero-point adjustment) is used to remove the offset error between different components. If the digital output value is $n=50$ for an analog input value of $0V$, select an offset value of 50 to correct the digital output value to $n=0$.

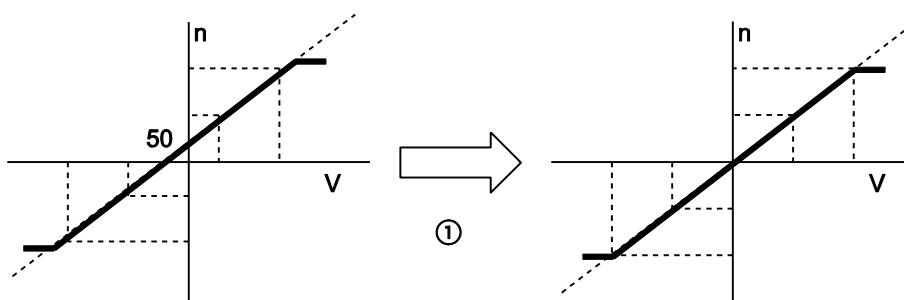

① Offset adjustment

- The gain value settings are used as a function to adjust small scale errors between different components. The gain value slope can be changed in a range of $0.9x-1.1x$.

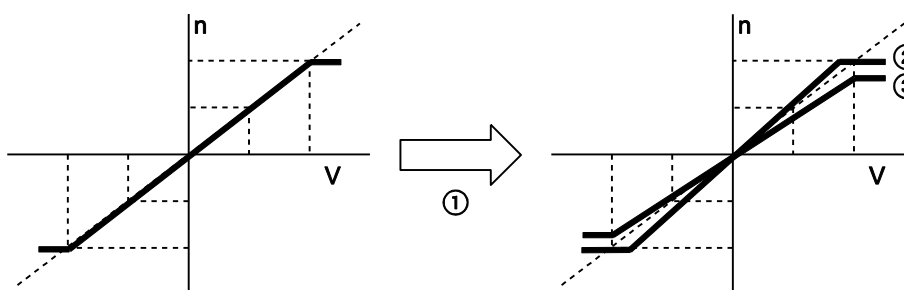

① Gain adjustment
 ② Gain 1.1x
 ③ Gain 0.9x

- Offset and gain processing is executed on a channel-by-channel basis.

Configuration

Name	Default	Setting range
Offset/gain processing	Disable	Select "Enable"
Offset value	0	To apply the setting, "Offset/gain processing" must be enabled. Setting range: -3000 to +3000 (specified with a signed integer)
Gain value	10000	To apply the setting, "Offset/gain processing" must be enabled. Setting range: +9000 to +11000 corresponding to a gain factor of 0.9x-1.1x (specified with a signed integer)

Note

The offset adjustment is applied to the unscaled value.

6.5 Scale conversion

Use scale conversion to set an easy-to-use data range. The digital output values are scaled to values in the specified range between preset minimum and maximum values before they are written to the CPU's input area. This function is convenient if used for unit conversion. Scale conversion is executed on a channel-by-channel basis.

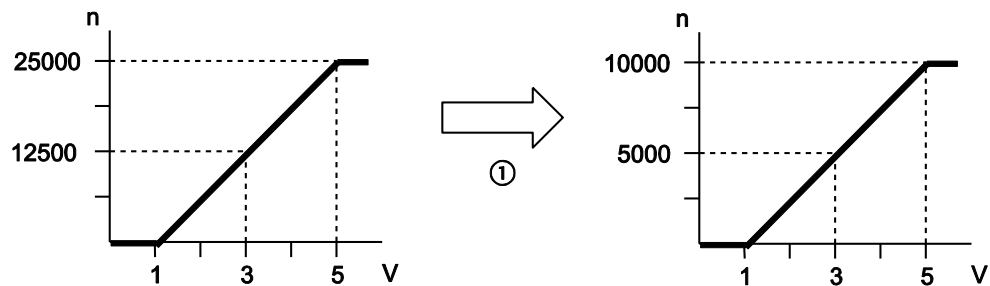

① Scale conversion

Configuration

Name	Default	Setting range
Scale conversion	Disable	Select "Enable"
Lower limit of scale	0	To apply the setting, "Scale conversion" must be enabled.
Upper limit of scale	10000	Setting range: -30000 to +30000 (specified with a signed integer)

Note

If data outside the lower or upper limit are acquired, scale conversion will be disabled and the lower or upper limit value will be written to the CPU's input area.

6.6 Limit alarm

This function compares the acquired data with the specified upper and lower limits and turns the corresponding flags to TRUE when these limits are exceeded.

The high limit alarm flag turns to TRUE if the digital output value exceeds the switch-on value for high limit alarm. The low limit alarm flag turns to TRUE if the digital output value drops below the switch-on value for low limit alarm.

The limit alarm is set and executed on a channel-by-channel basis.

To use the function, you must enable "Limit alarm" in the "Analog unit settings" dialog and turn the limit alarm control flag to TRUE.

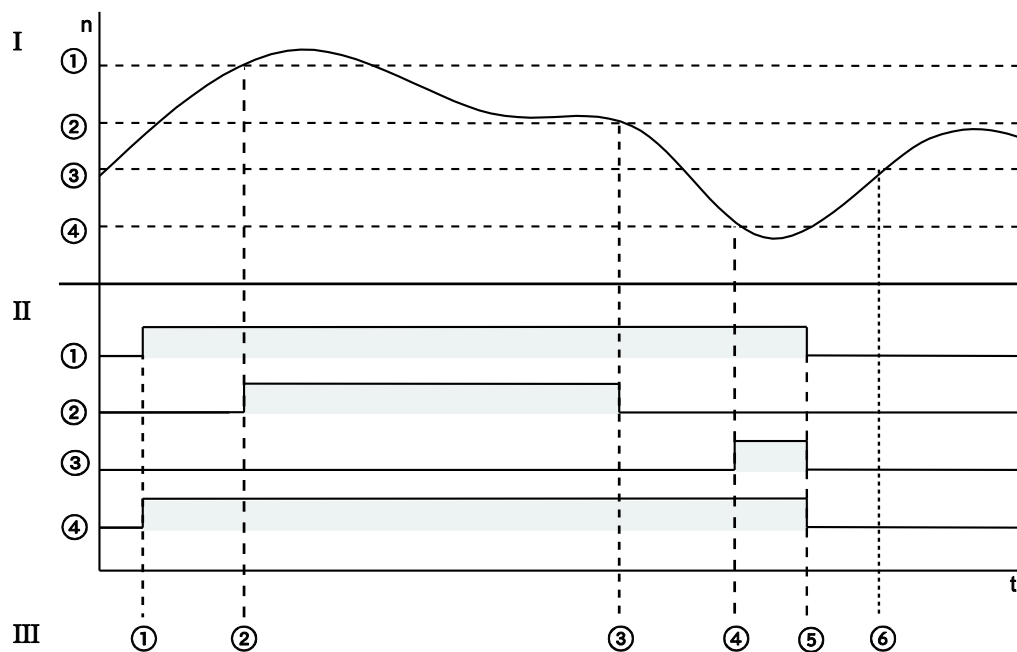

n	Digital output value
I	Limit values
①	High limit alarm switch-on value
②	High limit alarm switch-off value
③	Low limit alarm switch-off value
④	Low limit alarm switch-on value

II	Control and status flags
①	Limit alarm control flag
②	High limit alarm flag
③	Low limit alarm flag
④	Limit alarm active flag
III	Operation sequence
①	The limit alarm function is executed when the user program turns the limit alarm control flag to TRUE.
②	The high limit alarm flag turns to TRUE when the specified switch-on value for high limit alarm is reached.
③	The high limit alarm flag turns to FALSE when the specified switch-off value for high limit alarm is reached.
④	The low limit alarm flag turns to TRUE when the specified switch-on value for low limit alarm is reached.
⑤	All status flags turn to FALSE when the limit alarm control flag turns to FALSE and the limit alarm function is disabled. Therefore, the low limit alarm flag turns to FALSE before the switch-off value for low limit alarm is reached at ⑥.

For I/O addresses of control and status flags, see p. 20.

Configuration

Name	Default	Setting range
Limit alarm	Disable	Select "Enable"
High limit alarm switch-on value	1000	To apply the setting, "Limit alarm" must be enabled. Setting range: -31250 to +31250 (specified with a signed integer)
High limit alarm switch-off value	1000	
Low limit alarm switch-off value	0	
Low limit alarm switch-on value	0	

Note

When setting limit values, make sure the following is true:

- Low limit alarm switch-on value \leq Low limit alarm switch-off value
- Low limit alarm switch-off value $<$ High limit alarm switch-off value
- High limit alarm switch-off value \leq High limit alarm switch-on value

Sample program

The limit alarm function is activated on channel 0 of the analog unit, and the desired output turns to TRUE when the specified upper or lower limit is

detected. The output is specified using the function block FP_GET_UNIT_OFFSETS1. Please refer to the Control FPWIN Pro online help for detailed information.

POU Header

	Class	Identifier	Type	Initial
0	VAR_CONSTANT	iSlotNumber	INT	0
1	VAR	bSetLimitAlarmChannel0	BOOL	FALSE
2	VAR	bResetLimitAlarmChannel0	BOOL	FALSE
3	VAR	bHighLimitDetectedChannel0	BOOL	FALSE
4	VAR	bLowLimitDetectedChannel0	BOOL	FALSE

LD Body

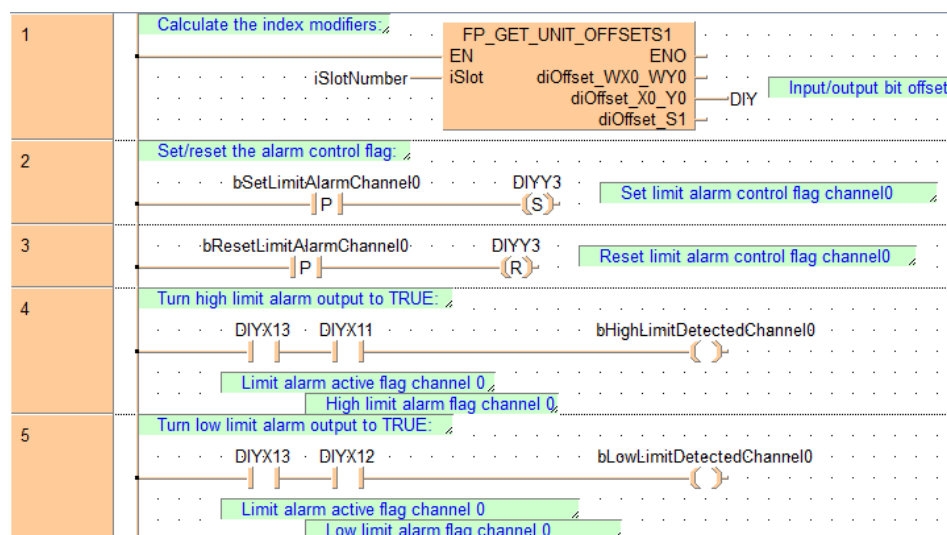

When bSetLimitAlarmChannel0 turns to TRUE, the limit alarm function on channel 0 is activated. When bResetLimitAlarmChannel0 turns to TRUE, the function is deactivated.

bHighLimitDetectedChannel0 turns to TRUE when the upper limit is reached. bLowLimitDetectedChannel0 turns to TRUE when the lower limit is reached.

6.7 Maximum and minimum value hold function

This function stores the maximum and minimum values of the acquired data in the unit memory area for each channel. See p. 76 for maximum and minimum value hold areas.

When the maximum/minimum hold control flag turns to TRUE, the current values will be stored as maximum and minimum values. These values will be refreshed continuously.

The maximum and minimum values will be held in the unit memory even when the control flag turns to FALSE or the CPU is switched to PROG mode.

The maximum and minimum values are held on a channel-by-channel basis.

To use the function, you must enable "Maximum and minimum value hold" in the "Analog unit settings" dialog and turn the maximum/minimum hold control flag to TRUE.

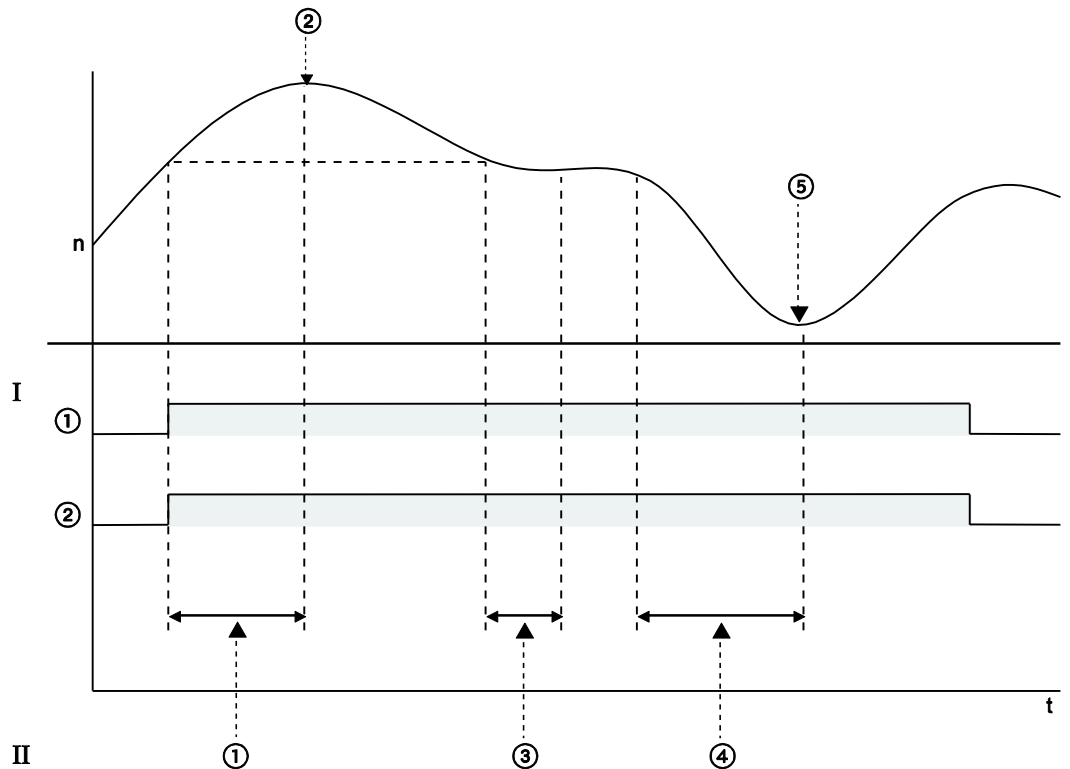

n	Digital output value
I	Control and status flags
①	Maximum/minimum hold control flag
②	Maximum/minimum hold active flag
II	Operation sequence
①	Maximum value is refreshed
②	Maximum value is held in unit memory
③	Minimum value is refreshed
④	
⑤	Minimum value is held in unit memory

For I/O addresses of control and status flags, see p. 20.

Configuration

Name	Default	Setting range
Maximum and minimum value hold	Disable	Select "Enable"

Sample program

The maximum and minimum value hold function is executed on channel 0 of the analog unit in slot 1, and the maximum and minimum values will be copied from the specified unit memory areas. The output is specified using the function block FP_GET_UNIT_OFFSETS1. Please refer to the Control FPWIN Pro online help for detailed information.

POU Header

	Class	Identifier	Type	Initial
0	VAR_CONSTANT	iSlotNumber	INT	0
1	VAR	bSetLimitAlarmChannel0	BOOL	FALSE
2	VAR	bResetLimitAlarmChannel0	BOOL	FALSE
3	VAR	bHighLimitDetectedChannel0	BOOL	FALSE
4	VAR	bLowLimitDetectedChannel0	BOOL	FALSE

LD Body

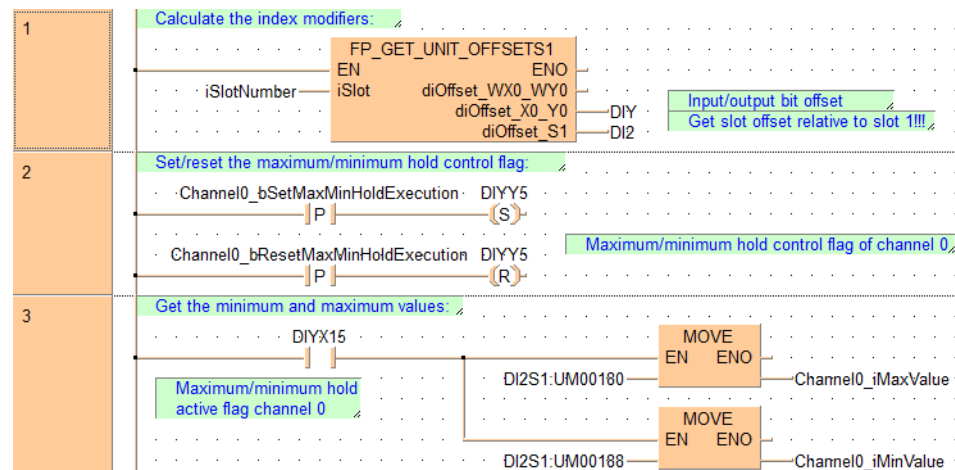

When Channel0_bSetMaxMinHoldExecution is TRUE, the maximum and minimum value hold function is activated. When Channel0_bResetMaxMinHoldExecution is TRUE, the maximum and minimum value hold function is deactivated.

When the maximum and minimum hold active flag for channel 0 is TRUE, the maximum and minimum values on channel 0 are read from the unit memory of the unit in slot 1 and copied to the variables Channel0_iMaxValue and Channel0_iMinValue.

6.8 Disconnection detection

The disconnection detection flag turns to TRUE and the ERROR LED will light if the analog input value does not reach a certain threshold.

Threshold for a voltage range of +1 to +5V: $\leq 0.7V$

Threshold for a current range of +4 to +20mA: $\leq 2.8mA$

If the input data exceeds the above values while the disconnection detection control flag is TRUE, the disconnection detection flag will turn to FALSE automatically, provided that "Disconnection detection flag reset" has been set to "Automatic". If "Manual" has been selected, the flag will be set to FALSE by turning the disconnection detection control flag to FALSE in the user program.

To use the function, you must enable "Disconnection detection" in the "Analog unit settings" dialog and turn the disconnection detection control flag to TRUE.

Disconnection detection is performed on a channel-by-channel basis.

Automatic reset of disconnection detection flag

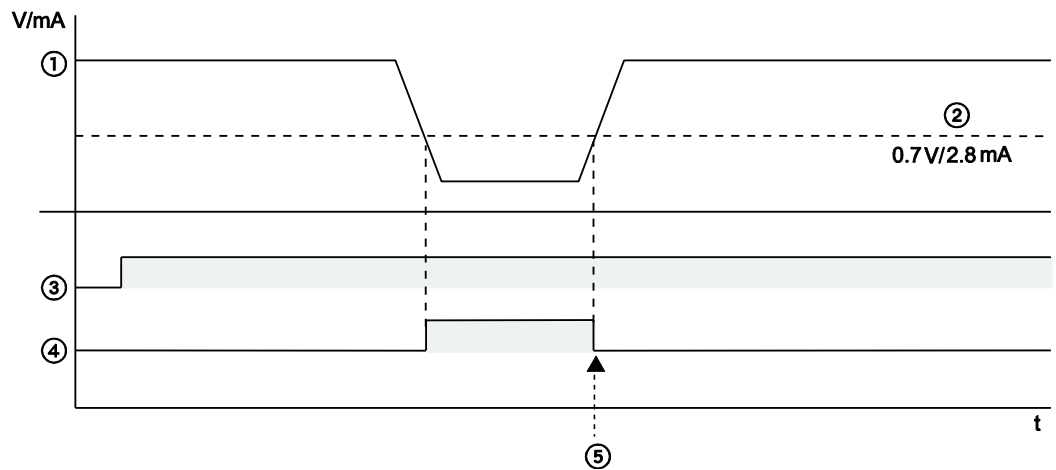

①	Analog input value
②	Threshold
③	Disconnection detection control flag
④	Disconnection detection flag (automatically turns to FALSE when
⑤	In automatic mode, the disconnection detection flag will automatically turn FALSE when the threshold is reached again.

Manual reset of disconnection detection flag

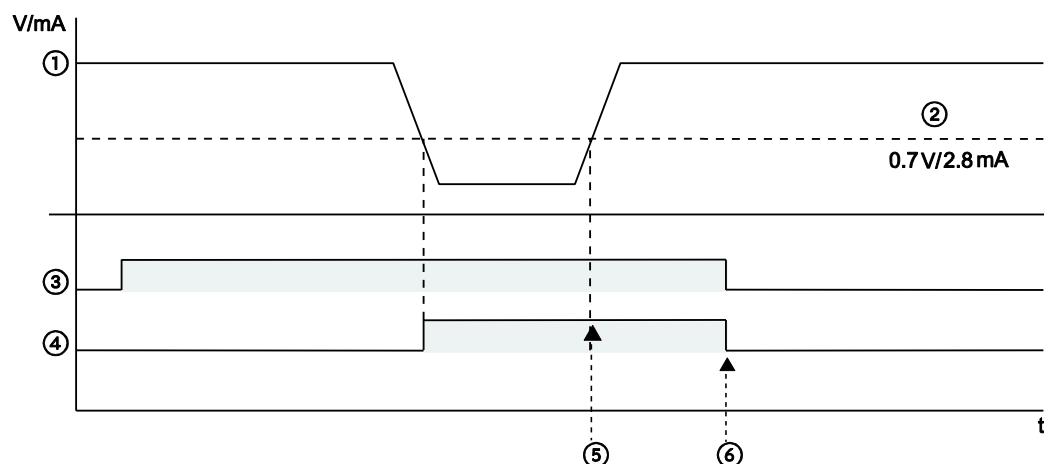

- | | |
|---|---|
| ① | Analog input value |
| ② | Threshold |
| ③ | Disconnection detection control flag |
| ④ | Disconnection detection flag |
| ⑤ | In manual mode, the disconnection detection flag will not automatically turn FALSE when the threshold is reached again. |
| ⑥ | The disconnection detection flag turns to FALSE when the disconnection detection control flag turns to FALSE. |

For I/O addresses of control and status flags, see p. 20.

Configuration (for automatic reset)

Name	Default	Setting range
Disconnection detection	Disable	Select "Enable"
Disconnection detection reset	Automatic	Select "Automatic"

Sample program

The disconnection detection is activated on channel 0. The disconnection detection flag turns to TRUE if a disconnection has been detected.

POU Header

	Class	Identifier	Type	Initial
0	VAR_CONSTANT	iSlotNumber	INT	0
1	VAR	Channel0_bSetDisconnectionDetection	BOOL	FALSE
2	VAR	Channel0_bResetDisconnectionDetection	BOOL	FALSE
3	VAR	bIsDisconnectionDetected	BOOL	FALSE

LD Body

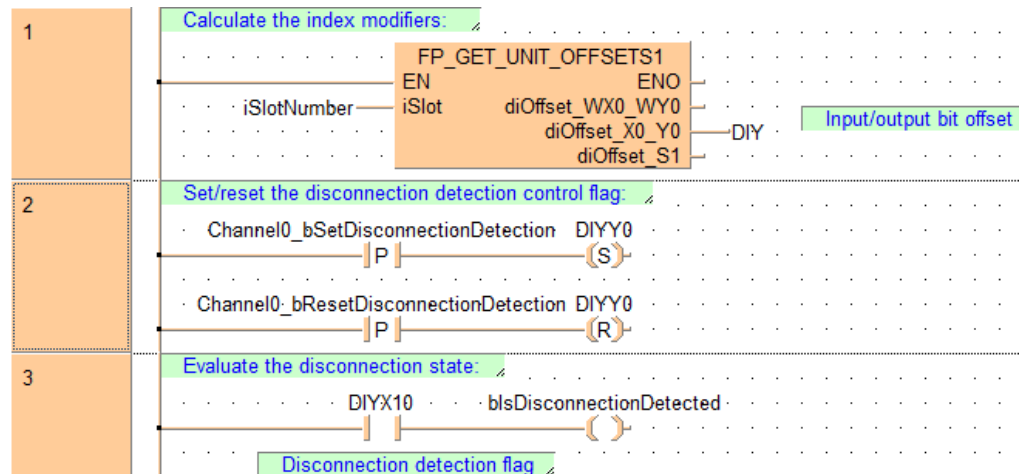

When Channel0_bSetDisconnectionDetection turns to TRUE, the disconnection detection function on channel 0 is activated. When Channel0_bResetDisconnectionDetection turns to TRUE, the disconnection detection function on channel 0 is deactivated.

When a disconnection is detected on channel 0, the disconnection detection flag turns to TRUE and the variable bIsDisconnectionDetected is set to TRUE.

Note

Disconnection detection is only performed for a voltage range of +1 to +5V or a current range of +4 to +20mA.

6.9 Buffer function

The buffer function stores digital output values acquired at a preset cycle in the unit memory. See p. 76 for buffer areas in the unit memory.

If a trigger signal is input while the buffer function is executed, a specified number of digital output values will be stored in the buffer (unit memory) at the specified sampling cycle.

Buffering can be triggered by one of the following events:

- The trigger flag turns to TRUE (see "Buffering by trigger flag" on p. 53)
- A signal edge occurs at an external trigger input (see "Buffering by external trigger input" on p. 55)

- The digital output value crosses a specified level (see "Buffering by trigger level" on p. 57)

Operation sequence

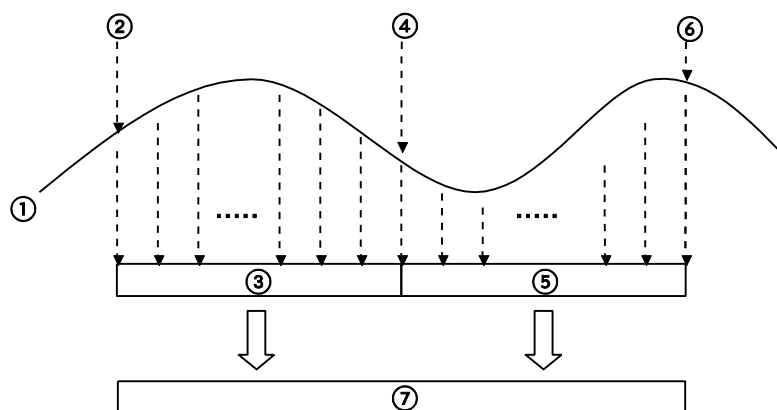
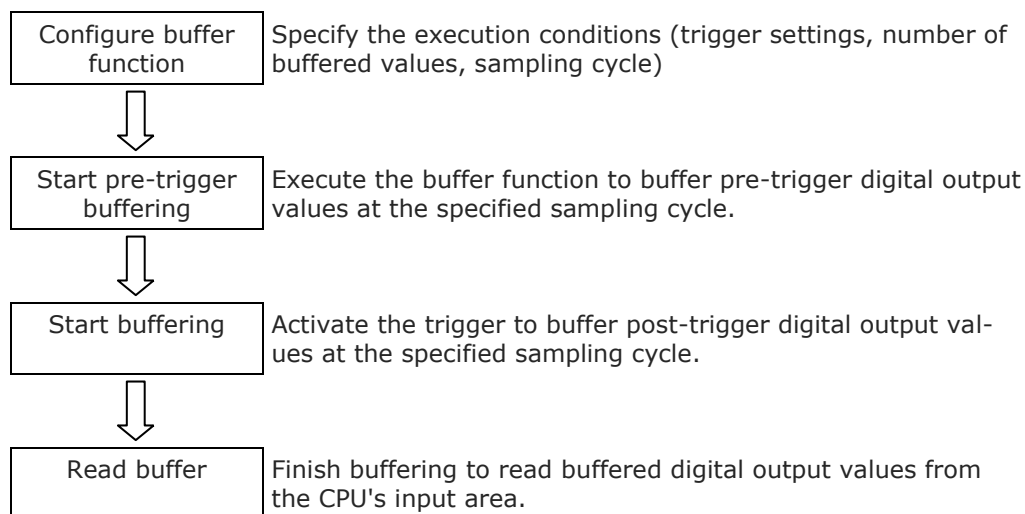

①	Digital output value
②	Execute buffer function
③	Pre-trigger values
④	Activate trigger
⑤	Post-trigger values
⑥	Finish buffering
⑦	Buffer (unit memory)

When buffering has finished after the specified number of digital output values has been captured, the digital pre-trigger and post-trigger values are stored on a channel-by-channel basis in the CPU's input area.

To use the function, you must enable "Buffer function" in the "Analog unit settings" dialog and turn the buffer function control flag to TRUE.

Configuration

Name	Default	Setting range
Buffer function	Disable	Select "Enable"
Trigger type	Trigger flag	Select a trigger signal to start buffering.
Trigger input	Unused	Select an external trigger input from TRIG0 to TRIG3 when using external triggering.
Level triggering channel	Unused	Select a channel from 0 to 3 when using level triggering.
Number of buffered values	1000	Set the number of captured values (words) to be stored in the buffer. Setting range: +1–+10000 (AFP7AD4H), +1–+8000 (AFP7AD8) The number of buffered values is the total sum of captured data values including the number of pre-trigger values.
Number of pre-trigger values	0	Set the number of captured values (words) to be stored before triggering. Setting range: +1–+9999 (AFP7AD4H), +1–+7999 (AFP7AD8) The number of pre-trigger values must be smaller than the number of buffered values.
Sampling cycle	1	Set the cycle for buffering digital output values. A trigger signal will only be detected at the end of the sampling cycle. The cycle time is obtained from the following formula. Insulated: set value (1–30000) × number of enabled channels × 5ms Non-insulated: set value (1–30000) × number of enabled channels × 0.025ms For AFP7AD8, only the "Non-insulated" setting is available.
Trigger level	0	Set a threshold when level triggering is used. Setting range: -31250–+31250

Sample program

In the "Analog unit settings" dialog make the following settings: "Trigger type": "Trigger flag", "Sampling cycle": 1, "Number of pre-trigger values": 1000, and "Number of buffered values": 10000. After buffering has completed, the captured data is copied to the specified memory area. The output is specified using the function block FP_GET_UNIT_OFFSETS1. Please refer to the Control FPWIN Pro online help for detailed information.

POU Header

	Class	Identifier	Type	Initial
0	VAR_CONSTANT	iSlotNumber	INT	0
1	VAR	bSetBufferFunctionControlFlag	BOOL	FALSE
2	VAR	bTriggerFlag	BOOL	FALSE
3	VAR	awBufferData	ARRAY [0..9999] OF WORD	[10000(0)]

LD Body

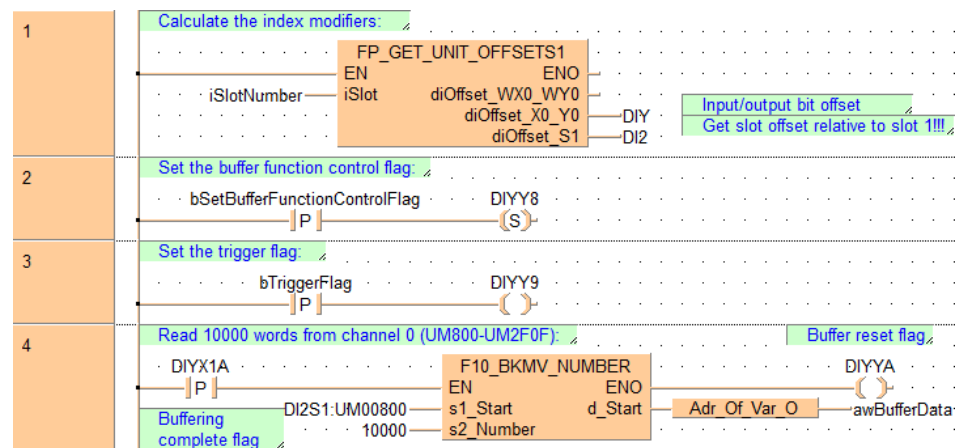

When `bSetBufferFunctionControlFlag` turns to TRUE, the buffer function is activated. When `bTriggerFlag` turns to TRUE, triggering is started. When the buffering complete flag turns to TRUE, 10000 words are read from the buffer at UM00800 of the analog unit at slot 1 and the data is stored in the array `awBufferData`. When reading is complete, the buffer reset flag turns to TRUE.

6.9.1 Buffering by trigger flag

The following diagram shows the buffer operation when the trigger flag turns to TRUE in a user program.

To use the function, you must enable "Buffer function" in the "Analog unit settings" dialog and turn the buffer function control flag to TRUE.

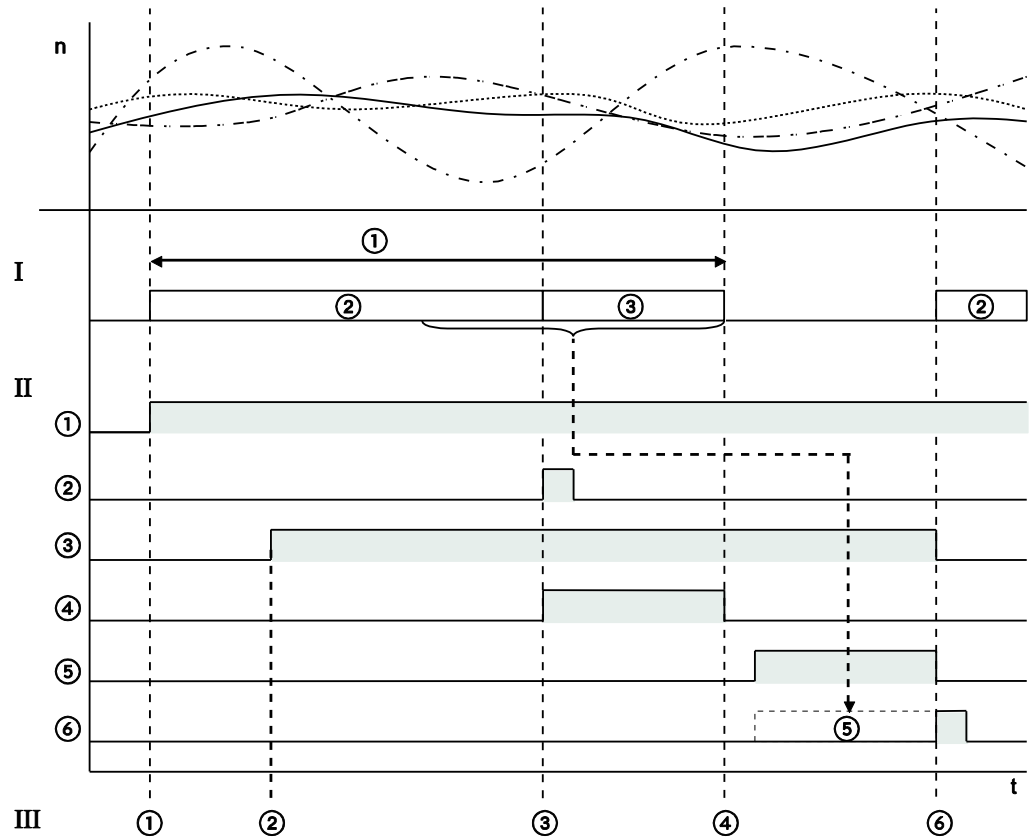

n	Digital output value (channel 0-3)
I	Buffer (unit memory)
①	Buffering at specified sampling cycle
②	Pre-trigger buffering
③	Post-trigger buffering
II	Control and status flags
①	Buffer function control flag
②	Trigger flag
③	Pre-trigger number match flag
④	Buffering in progress flag
⑤	Buffering complete flag
⑥	Buffer reset flag
III	Operation sequence
①	Pre-trigger buffering will start when the user program turns the buffer function control flag to TRUE.
②	When the specified number of pre-trigger values is reached, the pre-trigger number match flag turns to TRUE.
③	Buffering starts when the user program turns the trigger flag to TRUE. It continues until the specified number of buffered values is reached.
④	Buffering finishes when the specified number of buffered values has been captured.
⑤	The user program reads the buffered values and turns the buffer reset flag to TRUE.
⑥	The unit restarts pre-trigger buffering and waits for the next trigger signal.

For I/O addresses of control and status flags, see p. 20.

Note

- Any trigger signal will be ignored unless the buffer function control flag is TRUE.
- Buffering may be triggered even if the specified number of pre-trigger values has not been reached (the value in the memory area for pre-trigger values is 0).

6.9.2 Buffering by external trigger input

The following diagram shows the buffer operation when one of the external trigger inputs TRIG0–TRIG3 of the analog input unit turns to TRUE.

To use the function, you must enable "Buffer function" in the "Analog unit settings" dialog and turn the buffer function control flag to TRUE.

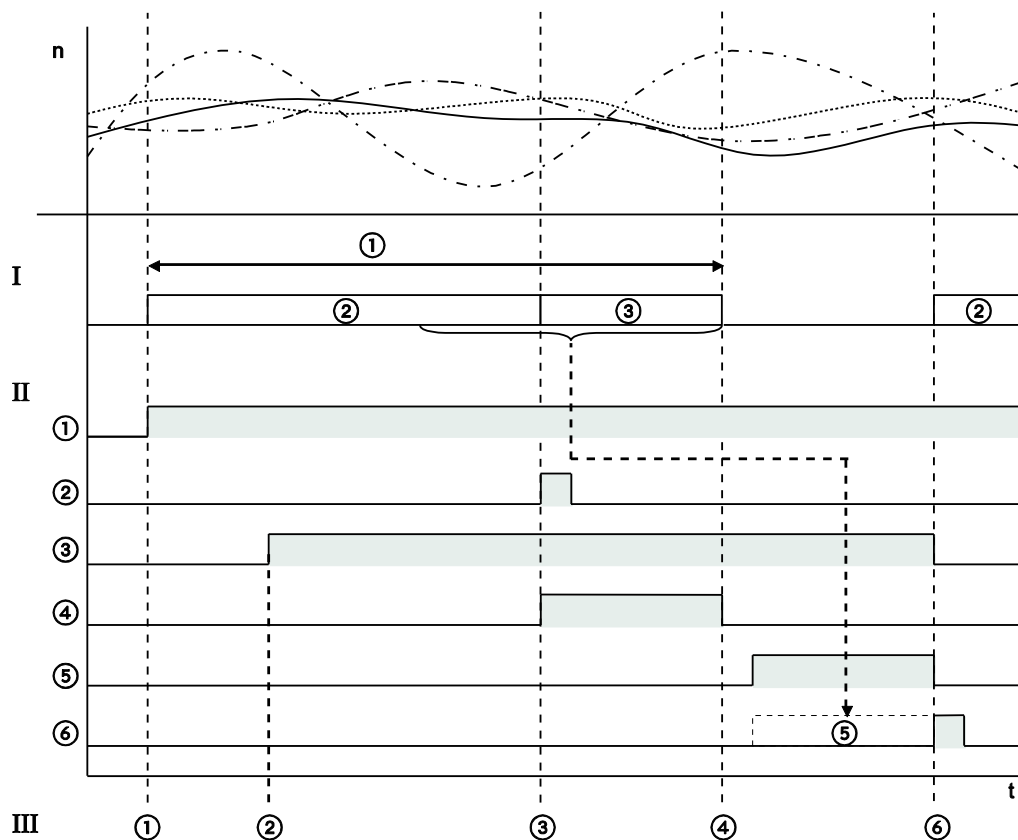

n	Digital output value (channel 0–3)
I	Buffer (unit memory)
①	Buffering at specified sampling cycle
②	Pre-trigger buffering
③	Post-trigger buffering

II	Control and status flags
①	Buffer function control flag
②	TRIG0
③	Pre-trigger number match flag
④	Buffering in progress flag
⑤	Buffering complete flag
⑥	Buffer reset flag
III	Operation sequence
①	Pre-trigger buffering will start when the user program turns the buffer function control flag to TRUE.
②	When the specified number of pre-trigger values is reached, the pre-trigger number match flag turns to TRUE.
③	Buffering starts at a rising edge of TRIG0. It continues until the specified number of buffered values is reached.
④	Buffering finishes when the specified number of buffered values has been captured.
⑤	The user program reads the buffered values and turns the buffer reset flag to TRUE.
⑥	The unit restarts pre-trigger buffering and waits for the next trigger signal.

For I/O addresses of control and status flags, see p. 20.

Note

- Any trigger signal will be ignored unless the buffer function control flag is TRUE.
- Buffering may be triggered even if the specified number of pre-trigger values has not been reached (the value in the memory area for pre-trigger values is 0).
- TRIG0 to TRIG3 of AFP7AD4H indicate input terminal numbers. Please note that they do not correspond to the analog input channels 0 to 3.
- Make sure "Trigger input" is not set to "Unused" in the "Analog unit settings" dialog.

6.9.3 Buffering by trigger level

The following diagram shows the buffer operation when the digital output value of the specified channel rises above or falls below the set trigger level.

To use the function, you must enable "Buffer function" in the "Analog unit settings" dialog and turn the buffer function control flag to TRUE.

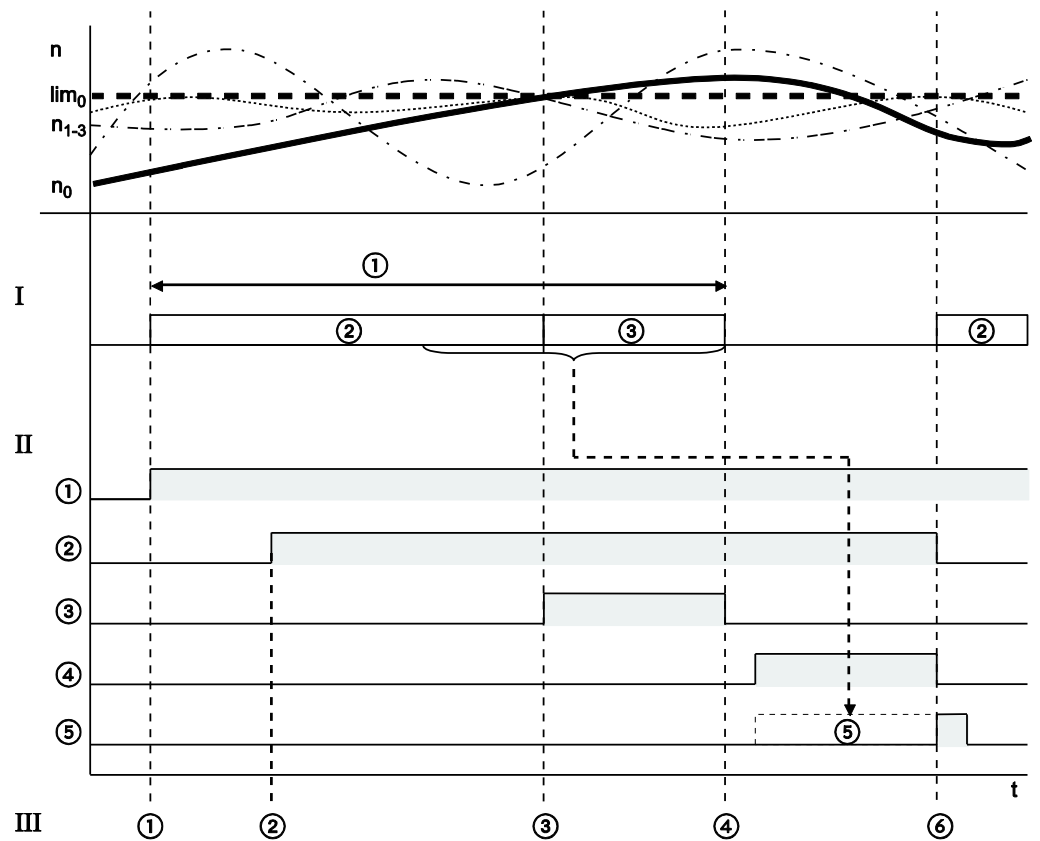

n	Digital output value
lim ₀	Trigger level (for digital output values on channel 0)
n ₁₋₃	Digital output value (channel 1–3)
n ₀	Digital output value (channel 0)
I	Buffer (unit memory)
①	Buffering at specified sampling cycle
②	Pre-trigger buffering
③	Post-trigger buffering
II	Control and status flags
①	Buffer function control flag
②	Pre-trigger number match flag
③	Buffering in progress flag
④	Buffering complete flag
⑤	Buffer reset flag
III	Operation sequence

①	Pre-trigger buffering will start when the user program turns the buffer function control flag to TRUE.
②	When the specified number of pre-trigger values is reached, the pre-trigger number match flag turns to TRUE.
③	Buffering starts when the digital output value of channel 0 rises above the specified trigger level. It continues until the specified number of buffered values is reached.
④	Buffering finishes when the specified number of buffered values has been captured.
⑤	The user program reads the buffered values and turns the buffer reset flag to TRUE.
⑥	The unit restarts pre-trigger buffering and waits for the next trigger signal.

For I/O addresses of control and status flags, see p. 20.

Note

- Any trigger signal will be ignored unless the buffer function control flag is TRUE.
- Buffering may be triggered even if the specified number of pre-trigger values has not been reached (the value in the memory area for pre-trigger values is 0).
- If "Trigger input rising edge" has been selected and the digital output value is above the trigger level from the beginning, buffering will start at the moment the value has dropped below the trigger level and rises above the level again. Similarly, the same is true if "Trigger input falling edge" has been selected.
- Depending on the sampling cycle, a value change at the trigger level may not be detected.
- Make sure "Level triggering channel" is not set to "Unused" in the "Analog unit settings" dialog.

6.10 Configuration by program

With the analog unit it is possible to make configuration settings by user program. Please refer to the appendix for the bit settings of each parameter (see p. 73).

To change the configuration, make the desired bit settings in the unit memory of the corresponding parameter and write "16#55AA" to unit memory UM00028. After the configuration has been updated, unit memory UM00028 will be set to 0.

Sample program (AFP7AD4H)

Make the following settings by user program:

- Channel-to-channel insulation: Insulated
- Range setting, channel 0: 4–20mA
- Range setting, channel 1: 4–20mA
- Conversion processing, channel 2–3: Disable

POU Header

	Class	Identifier	Type	Initial
0	VAR_CONSTANT	iSlotNumber	INT	0
1	VAR	bConfigure	BOOL	FALSE
2	VAR	bConfigurationUpdateInProgress	BOOL	FALSE
3	VAR	bConfigurationUpdateComplete	BOOL	FALSE
4	VAR	bReadAnalogInputData	BOOL	FALSE
5	VAR	iChannel0InputData	INT	0
6	VAR	iChannel1InputData	INT	0

LD Body

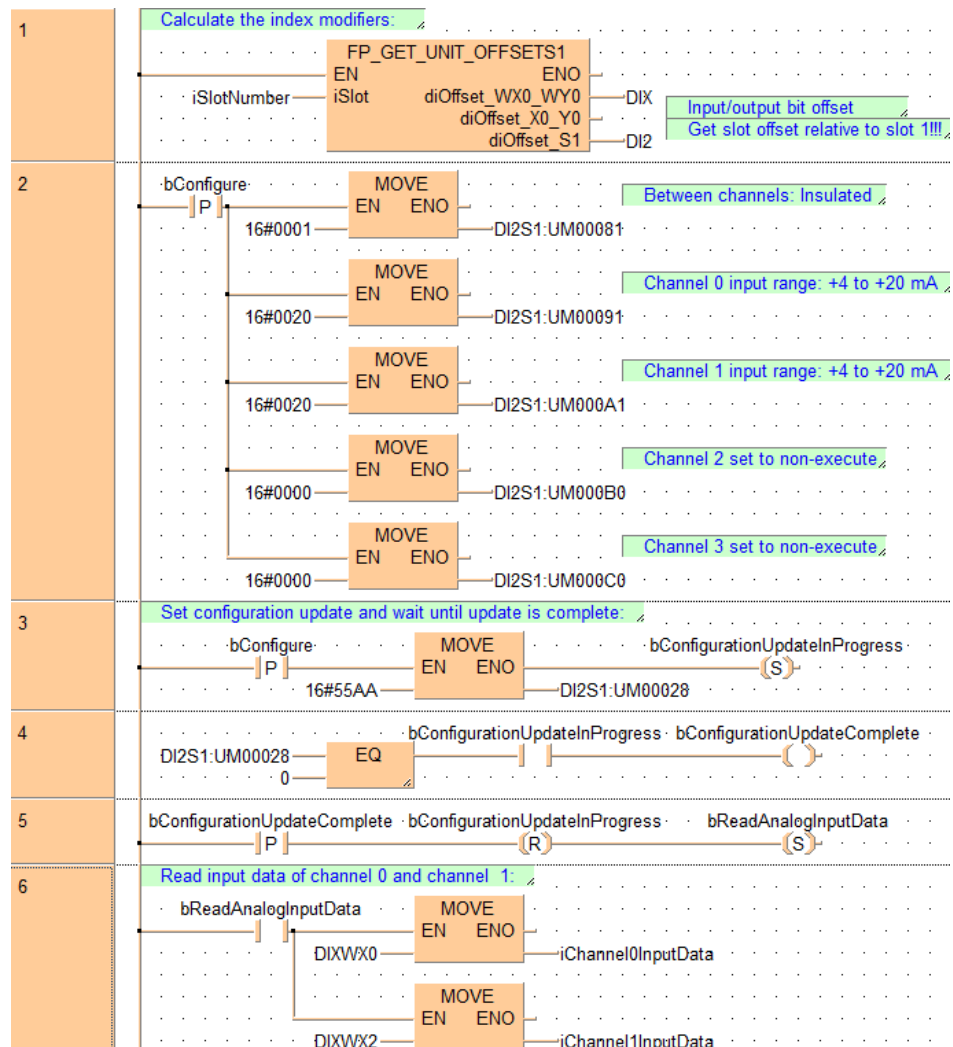

When bConfigure turns to TRUE and 16#55AA is written to unit memory UM00028, the configuration is updated. When the update is complete, 0 is written to UM00028 and writing of the output data starts.

Chapter 7

Troubleshooting

7.1 Failure in reading analog input data

If an error occurs during the reading of analog input data:

- Check that I/O allocations are correct.
- Check the connections of the terminal block.
- Check the configuration settings.

7.2 Unstable analog input value

If the analog input value is unstable:

- Use twisted pair wires and check that the wire is properly shielded.
- Check that the analog input wires are not placed close to power lines or high-tension lines or bundled with the lines.
- Check that there are no power lines, high-voltage lines, high-capacity relays, or noise-generating equipment, such as inverters, close to the analog unit.
- Check that the voltage or current range setting is set correctly.

7.3 Incorrect digital output values with current input

If no correct digital output values can be obtained with the current input:

- Check the connections of the terminal block.
- Check the connections of the input device.
- Check that the range setting has been set to current input.

Chapter 8

Specifications

8.1 General specifications

Item	Description	
Ambient temperature	0 to +55°C	
Storage temperature	-40 to +70°C	
Ambient humidity	10%–95% RH (at 25°C, non-condensing)	
Storage humidity	10%–95% RH (at 25°C, non-condensing)	
Breakdown voltage Cutoff current: 5mA (factory setting)	Input terminals/Output terminals ↔ Power supply terminal/Function earth of CPU	500V AC for 1min
	Between analog input channels	200V AC for 1min
Insulation resistance (measured with a 500V DC megger)	Input terminals/Output terminals ↔ Power supply terminal/Function earth of CPU	100MΩ (measured with a 500V DC megger)
Vibration resistance ¹⁾	5–8.4Hz, amplitude of 3.5mm 8.4–150Hz, constant acceleration of 9.8m/s ² 10min on 3 axes (in X, Y, and Z direction), 10 sweeps (1 octave/min)	
Shock resistance ¹⁾	≥147m/s ² , 3 times on 3 axes (in X, Y, and Z direction)	
Noise immunity (Power supply terminal of CPU)	1000Vp-p, with pulse widths 50ns and 1μs (based on in-house measurements)	
Operation conditions	Free from corrosive gases and excessive dust	
Conformity to CE Directives	EMC: EN 61131-2	
Overvoltage category	II	
Pollution degree	2	

¹⁾ Based on JIS B 3502 and IEC 61131-2.

8.2 Performance specifications

AFP7AD4H

Item	Description	
Inputs	4 channels	
Input range (Resolution)	Voltage	-10 to +10V DC (1/62500) 0 to +10V DC (1/31250) 0 to +5V DC (1/31250) +1 to +5V DC (1/25000) ¹⁾
	Current	0 to +20mA (1/31250) +4 to +20mA (1/25000) ²⁾
Conversion time	25μs/channel (non-insulated); 5ms/channel (insulated)	
Total accuracy	Max. ±0.05% F.S. at +25°C Max. ±0.1% F.S. at 0°C to +55°C	

Item		Description
Input impedance	Voltage	≈1MΩ
	Current	≈250Ω
Absolute maximum input	Voltage	-15 to +15V
	Current	-30 to +30mA
Insulation method		Input terminals ↔ Internal circuit: <ul style="list-style-type: none"> • Optical coupler • Insulated DC-DC converter Between channels: PhotoMOS relay
Channel deactivation		To speed up conversion, disable "Conversion processing" for all unused channels.
Input range selection		Settings per channel
Average processing	Count-based average	Setting range: 2–60000 counts
	Time-based average	Setting range: 1–1500ms (non-insulated) and 200–60000ms (insulated)
	Moving average	Setting range: 2–2000 counts
Offset/gain processing	Offset value	Setting range: -3000 to +3000
	Gain value	Setting range: +9000 to +11000 (90%–110%)
Scale conversion		Setting range: -30000 to +30000
Limit alarm		Available
Maximum and minimum value hold		Available
Disconnection detection		Available for a voltage range of +1 to +5V or a current range of +4 to +20mA Automatic or manual reset of disconnection detection flag
Buffer function		Max. 10000 words/channel Available triggers: <ul style="list-style-type: none"> • Trigger flag • Trigger input • Trigger level

¹⁾ Full scale (F.S.) for accuracy specifications is 0 to +5V.

²⁾ Full scale (F.S.) for accuracy specifications is 0 to +20mA.

Note

The unit configuration, which is stored in the unit memory (UM), can be changed via the [Advanced] button in the "I/O map and unit configuration" dialog or by specifying the settings in a user program. See p. 58.

AFP7AD8

Item		Description
Inputs		8 channels
Input range (Resolution)	Voltage	-10 to +10V DC (1/62500) 0 to +10V DC (1/31250) 0 to +5V DC (1/31250) +1 to +5V DC (1/25000) ¹⁾
	Current	0 to +20mA (1/31250) +4 to +20mA (1/25000) ²⁾
Conversion time		25µs/channel
Total accuracy		Max. ±0.1% F.S. at +25°C Max. ±0.3% F.S. at 0°C to +55°C
Input impedance	Voltage	≈1MΩ
	Current	≈250Ω
Absolute maximum input	Voltage	-15 to +15V
	Current	-30 to +30mA
Insulation method		Input terminals ↔ Internal circuit: Optical coupler, insulated DC/DC converter Between channels: PhotoMOS relay
Channel deactivation		To speed up conversion, disable "Conversion processing" for all unused channels.
Input range selection		Settings per channel
Average processing	Count-based average	Setting range: 2–60000 counts
	Time-based average	Setting range: 1–1500ms
	Moving average	Setting range: 2–2000 counts
Offset/gain processing	Offset value	Setting range: -3000 to +3000
	Gain value	Setting range: +9000 to +11000 (90%–110%)
Scale conversion		Setting range: -30000 to +30000
Limit alarm		Available
Maximum and minimum value hold		Available
Disconnection detection		Available for a voltage range of +1 to +5V or a current range of +4 to +20mA Automatic or manual disconnection detection reset
Buffer function		Max. 8000 words/channel Available triggers: trigger flag, external trigger input, value change in analog input

¹⁾ Full scale (F.S.) for accuracy specifications is 0 to +5V.

²⁾ Full scale (F.S.) for accuracy specifications is 0 to +20mA.

Note

The unit configuration, which is stored in the unit memory (UM), can be changed via the [Advanced] button in the "I/O map and unit configuration" dialog or by specifying the settings in a user program. See p. 58.

8.3 I/O allocation

8.3.1 Digital values and status flags

After A/D conversion, the digital output values are written to the CPU's input area (WX) and processed. Status flags are also allocated to the CPU's inputs.

The I/O addresses in the table show offset addresses. I/O addresses actually allocated are based on the first word number allocated to the unit.

Example: If the first word address is 10, the address numbers for the digital output value and the error flag on channel 0 will be WX10 and X11F, respectively.

Note

- All buffer flags (Buffer function active flag, Buffering in progress flag, Buffering complete flag, Pre-trigger number match flag) are allocated to the inputs of channel 0.
- The default value of the digital output value is 0.
- The default value of the status flags is 16#0.

Channel 0–3

I/O addresses								Name
Channel 0		Channel 1		Channel 2		Channel 3		
WX0	X0–XF	WX2	X20–X2F	WX4	X40–X4F	WX6	X60–X6F	Digital output value (16 bits) ¹⁾
WX1	X10	WX3	X30	WX5	X50	WX7	X70	Disconnection detection flag ²⁾
	X11		X31		X51		X71	High limit alarm flag ³⁾
	X12		X32		X52		X72	Low limit alarm flag ⁴⁾
	X13		X33		X53		X73	Limit alarm active flag ⁵⁾
	X14		X34		X54		X74	Not used
	X15		X35		X55		X75	Maximum/minimum hold active flag ⁶⁾
	X16–X17		X36–X37		X56–X57		X76–X77	Not used
	X18		—		—		—	Buffer function active flag ⁷⁾
	X19		—		—		—	Buffering in progress flag ⁸⁾
	X1A		—		—		—	Buffering complete flag ⁹⁾
	X1B		—		—		—	Pre-trigger number match flag ¹⁰⁾
	X1C–X1E		X3C–X3E		X5C–X5E		X7C–X7E	Not used
	X1F		X3F		X5F		X7F	Error flag ¹¹⁾

Channel 4–7 (AFP7AD8 only)

I/O addresses								Name
Channel 4		Channel 5		Channel 6		Channel 7		
WX8	X80–X8F	WX10	X100–X10F	WX12	X120–X12F	WX14	X140–X14F	Digital output value (16 bits) ¹⁾
WX9	X90	WX11	X110	WX13	X130	WX15	X150	Disconnection detection flag ²⁾
	X91		X111		X131		X151	High limit alarm flag ³⁾
	X92		X112		X132		X152	Low limit alarm flag ⁴⁾
	X93		X113		X133		X153	Limit alarm active flag ⁵⁾
	X94		X114		X134		X154	Not used
	X95		X115		X135		X155	Maximum/minimum hold active flag ⁶⁾
	X96–X97		X116–X117		X136–X137		X156–X157	Not used
	—		—		—		—	Buffer function active flag ⁷⁾
	—		—		—		—	Buffering in progress flag ⁸⁾
	—		—		—		—	Buffering complete flag ⁹⁾
	—		—		—		—	Pre-trigger number match flag ¹⁰⁾
	X9C–X9E		X11C–X11E		X13C–X13E		X15C–X15E	Not used
	X9F		X11F		X13F		X15F	Error flag ¹¹⁾

1) Digital output value

Memory area for digital values after conversion of the analog input values. If scale conversion has been set, the corresponding scaled values are stored here.

Voltage range	Current range	Digital output value
-10 to +10V	-	-31250 to +31250
0 to +10V or 0 to +5V	-	0 to +31250
+1 to +5V	-	0 to +25000
-	0 to +20mA	0 to +31250
-	+4 to +20mA	0 to +25000

For AFP7AD8 set to voltage input: The digital output value corresponding to an analog input value of about 2V is stored for channels which are not connected to an input.

2) Disconnection detection flag

TRUE when a disconnection has been detected.

FALSE when the connection has been restored.

(Valid for 1–5V and 4–20mA ranges only.)

3) High limit alarm flag

TRUE when the digital output value exceeds the switch-on value for high limit alarm.

4) Low limit alarm flag

TRUE when the digital output value drops below the switch-on value for low limit alarm.

5) Limit alarm active flag

TRUE when the limit alarm function is active.

6) Maximum/minimum hold active flag

TRUE when the maximum and minimum value hold function is active.

7) Buffer function active flag

TRUE when the buffer function is active.

8) Buffering in progress flag

TRUE when buffering starts after the trigger event.

FALSE when the set number of values to be buffered has been captured.

9) Buffering complete flag

TRUE when buffering has completed and the buffer can be accessed for reading.

FALSE when reading of buffered data has completed.

10) Pre-trigger number match flag

TRUE when the set number of values to be buffered before the trigger event has been captured.

FALSE when reading of buffered data has completed.

11) Error flag

TRUE when an error has occurred.

8.3.2 Control flags

Control flags are allocated to the CPU's output area.

The I/O addresses in the table show offset addresses. I/O addresses actually allocated are based on the first word number allocated to the unit.

Example: If the first word number is 10, the address numbers for the disconnection detection execution flag and the error flag reset flag on channel 0 will be Y100 and Y10F, respectively.

Note

All buffer flags (Buffer function control flag, Trigger flag, and Buffer reset flag) are allocated to the outputs of channel 0.

Channel 0–3

I/O addresses								Name
Channel 0		Channel 1		Channel 2		Channel 3		
WY0	Y0	WY1	Y10	WY2	Y20	WY3	Y30	Disconnection detection control flag ¹⁾
	Y1–Y2		Y11–Y12		Y21–Y22		Y31–Y32	Not used
	Y3		Y13		Y23		Y33	Limit alarm control flag ²⁾
	Y4		Y14		Y24		Y34	Not used
	Y5		Y15		Y25		Y35	Maximum/minimum hold control flag ³⁾
	Y6–Y7		Y16–Y17		Y26–Y27		Y36–Y37	Not used
	Y8		—		—		—	Buffer function control flag ⁴⁾
	Y9		—		—		—	Trigger flag ⁵⁾
	YA		—		—		—	Buffer reset flag ⁶⁾
	YB–YE		Y1B–Y1E		Y2B–Y2E		Y3B–Y3E	Not used
	YF		Y1F		Y2F		Y3F	Error reset flag ⁷⁾

Channel 4–7 (AFP7AD8 only)

I/O addresses								Name
Channel 4		Channel 5		Channel 6		Channel 7		
WY4	Y40	WY5	Y50	WY6	Y60	WY7	Y70	Disconnection detection control flag ¹⁾
	Y41–Y42		Y51–Y52		Y61–Y62		Y71–Y72	Not used
	Y43		Y53		Y63		Y73	Limit alarm control flag ²⁾
	Y44		Y54		Y64		Y74	Not used
	Y45		Y55		Y65		Y75	Maximum/minimum hold control flag ³⁾
	Y46–Y47		Y56–Y57		Y66–Y67		Y76–Y77	Not used
	—		—		—		—	Buffer function control flag ⁴⁾
	—		—		—		—	Trigger flag ⁵⁾
	—		—		—		—	Buffer reset flag ⁶⁾
	Y4B–Y4E		Y5B–Y5E		Y6B–Y6E		Y7B–Y7E	Not used
	Y4F		Y5F		Y6F		Y7F	Error reset flag ⁷⁾

¹⁾ Disconnection detection control flag

TRUE to execute the disconnection detection function.

FALSE to turn the disconnection detection flag (Xn0) to FALSE.

(Valid for 1–5V and 4–20mA ranges only.)

²⁾ Limit alarm control flag

TRUE to execute the limit alarm function.

FALSE to turn the high limit alarm flag (Xn1) and low limit alarm flag (Xn2) to FALSE.

3) **Maximum/minimum hold control flag**

TRUE to execute the maximum/minimum hold function.

FALSE to turn the maximum/minimum hold active flag (Xn5) to FALSE.

4) **Buffer function control flag**

TRUE to enable trigger acceptance.

FALSE to initialize the internal status.

5) **Trigger flag**

TRUE to start buffering.

6) **Buffer reset flag**

TRUE for one scan when reading of the buffer has been completed. Clears the buffer and enables trigger acceptance.

7) **Error reset flag**

TRUE to reset the error flag (XnF).

8.4 Unit memory addresses

8.4.1 Allocation of unit memory addresses

There is no need to set unit memory values, because unit memory values will be written automatically if they are set in the "Analog unit settings" dialog of Control FPWIN Pro. To change parameters by user program, write the desired value to the parameter's unit memory address. See p. 58.

Channel 0–3

Setting item		Unit memory address			
		Channel 0	Channel 1	Channel 2	Channel 3
Unit memory update		UM00028			
Channel-to-channel insulation		UM00081 (FP7AD4H only)			
Buffer function	Execution/non-execution settings	UM00088			
	Trigger type	UM00089			
	Number of buffered values	UM0008A			
	Number of pre-trigger values	UM0008B			
	Sampling cycle	UM0008C			
	Trigger level	UM0008D			
Conversion processing		UM00090	UM000A0	UM000B0	UM000C0
Range setting		UM00091	UM000A1	UM000B1	UM000C1
Function setting 1	Average processing Offset/gain processing Scale conversion	UM00092	UM000A2	UM000B2	UM000C2
Function setting 2	Limit alarm Maximum and minimum value hold Disconnection detection Disconnection detection reset	UM00093	UM000A3	UM000B3	UM000C3
Average count or time period		UM00094	UM000A4	UM000B4	UM000C4
Offset value		UM00095	UM000A5	UM000B5	UM000C5
Gain value		UM00096	UM000A6	UM000B6	UM000C6
Scale conversion	Upper limit of scale	UM00097	UM000A7	UM000B7	UM000C7
	Lower limit of scale	UM00098	UM000A8	UM000B8	UM000C8
Limit alarm	High limit alarm switch-on value	UM00099	UM000A9	UM000B9	UM000C9
	High limit alarm switch-off value	UM0009A	UM000AA	UM000BA	UM000CA
	Low limit alarm switch-off value	UM0009B	UM000AB	UM000BB	UM000CB
	Low limit alarm switch-on value	UM0009C	UM000AC	UM000BC	UM000CC
Maximum and minimum value hold	Maximum hold value	UM00180	UM00181	UM00182	UM00183
	Minimum hold value	UM00188	UM00189	UM0018A	UM0018B
Buffer function	Buffer (unit memory)	UM00800– UM02F0F	UM03000– UM0570F	UM05800– UM07F0F	UM08000– UM0A70F

Channel 4–7 (AFP7AD8 only)

Setting item		Unit memory address			
		Channel 4	Channel 5	Channel 6	Channel 7
Unit memory update		UM00028			
Buffer function	Execution/non-execution settings	UM00088			
	Trigger type	UM00089			
	Number of buffered values	UM0008A			
	Number of pre-trigger values	UM0008B			
	Sampling cycle	UM0008C			
	Trigger level	UM0008D			
Conversion processing		UM000D0	UM000E0	UM000F0	UM00100
Range setting		UM000D1	UM000E1	UM000F1	UM00101
Function setting 1	Average processing Offset/gain processing Scale conversion	UM000D2	UM000E2	UM000F2	UM00102
Function setting 2	Limit alarm Maximum and minimum value hold Disconnection detection Disconnection detection reset	UM000D3	UM000E3	UM000F3	UM00103
Average count or time period		UM000D4	UM000E4	UM000F4	UM00104
Offset value		UM000D5	UM000E5	UM000F5	UM00105
Gain value		UM000D6	UM000E6	UM000F6	UM00106
Scale conversion	Upper limit of scale	UM000D7	UM000E7	UM000F7	UM00107
	Lower limit of scale	UM000D8	UM000E8	UM000F8	UM00108
Limit alarm	High limit alarm switch-on value	UM000D9	UM000E9	UM000F9	UM000109
	High limit alarm switch-off value	UM000DA	UM000EA	UM000FA	UM0010A
	Low limit alarm switch-off value	UM000DB	UM000EB	UM000FB	UM0010B
	Low limit alarm switch-on value	UM000DC	UM000EC	UM000FC	UM0010C
Maximum and minimum value hold	Maximum hold value	UM00184	UM00185	UM00186	UM00187
	Minimum hold value	UM0018C	UM0018D	UM0018E	UM0018F
Buffer function	Buffer (unit memory)	UM08100– UM0A03F	UM0A040– UM0BF7F	UM0BF80– UM0DEBF	UM0DEC0– UM0DFF

8.4.2 Bit settings in unit memory areas

General settings (common to all channels)

Unit memory address	Name	Default	Setting range	
UM00028	Unit memory update	16#0	16#0: Unused 16#55AA: Refresh unit configuration To change the configuration, make the desired bit settings in the unit memory of the corresponding parameter and write "16#55AA" to unit memory UM00028. After the configuration has been updated, unit memory UM00028 will be set to 0.	
UM00081	Channel-to-channel insulation	16#0	16#0: Non-insulated 16#1: Insulated (AFP7AD4H only)	
UM00088	Buffer function Disable/Enable	16#0	16#0: Disable 16#1: Enable	
UM00089	Trigger type	16#0	Bit 0-3	16#0: Trigger flag 16#1: Trigger input rising edge 16#2: Trigger input falling edge 16#4: Trigger level rising edge 16#8: Trigger level falling edge
	Trigger input (AFP7AD4H only)	16#0	Bit 4-7	16#0: Unused 16#1: TRIG0 16#2: TRIG1 16#4: TRIG2 16#8: TRIG3
	Trigger level	16#0	Bit 8-11	AFP7AD4H: 16#0: Unused 16#1: Channel 0 16#2: Channel 1 16#4: Channel 2 16#8: Channel 3 AFP7AD8: 16#0: Channel 0 16#1: Channel 1 16#2: Channel 2 16#3: Channel 3 16#4: Channel 4 16#5: Channel 5 16#6: Channel 6 16#7: Channel 7
			Bit 12-15	Not used
UM0008A	Number of buffered values	1000	Setting range: +1 to +10000 (AFP7AD4H) +1 to +8000 (AFP7AD8)	
UM0008B	Number of pre-trigger values	0	Setting range: 0 to +9999 (AFP7AD4H) 0 to +7999 (AFP7AD8)	
UM0008C	Sampling cycle	1	Insulated: set value (1-30000) × number of enabled channels × 5ms Non-insulated: set value (1-30000) × number of enabled channels × 0.025ms For AFP7AD8, only the "Non-insulated" setting is available.	
UM0008D	Trigger level	0	Setting range: -31250 to +31250	

Individual settings (settings per channel)

The unit memory addresses are listed in ascending order for the supported channels (e.g. first unit memory address applies to channel 0, second to channel 1 etc.).

Unit memory address	Name	Default	Setting range	
UM00090 UM000A0 UM000B0 UM000C0 UM000D0 UM000E0 UM000F0 UM00100	Conversion processing	16#1	16#0: Disable 16#1: Enable	
UM00091 UM000A1 UM000B1 UM000C1 UM000D1 UM000E1 UM000F1 UM00101	Range setting	16#1	16#1: Voltage input -10 to +10V 16#2: Voltage input 0 to +10V 16#4: Voltage input 0 to +5V 16#8: Voltage input +1 to + 5V 16#10: Current input 0 to +20mA 16#20: Current input +4 to +20mA	
UM00092 UM000A2 UM000B2 UM000C2 UM000D2 UM000E2 UM000F2 UM00102	Average processing	16#0	Bit 0-3	16#0: Disable 16#1: Count-based average 16#2: Time-based average 16#4: Moving average
	Offset/gain processing	16#0	Bit 4-7	16#0: Disable 16#1: Enable
	Scale conversion	16#0	Bit 8-11 Bit 12-15	16#0: Disable 16#1: Enable Not used
UM00093 UM000A3 UM000B3 UM000C3 UM000D3 UM000E3 UM000F3 UM00103	Limit alarm	16#0	Bit 0-3	16#0: Disable 16#1: Enable
	Maximum and minimum value hold	16#0	Bit 4-7	16#0: Disable 16#1: Enable
	Disconnection detection	16#0	Bit 8-11	16#0: Disable 16#1: Enable
	Disconnection detection reset	16#0	Bit 12-15	16#0: Automatic 16#1: Manual
UM00094 UM000A4 UM000B4 UM000C4 UM000D4 UM000E4 UM000F4 UM00104	Average count or time period	200	To apply the setting, an average processing method must be enabled. Count-based average: 2-60000 ^{*)} counts Time-based average: 1-1500ms ^{*)} (non-insulated) 200-60000ms ^{*)} (insulated) Moving average: 2-2000 ^{*)} counts ^{*)} (specified with an unsigned integer) For AFP7AD8, only the "Non-insulated" setting is available.	

Unit memory address	Name	Default	Setting range
UM00095 UM000A5 UM000B5 UM000C5 UM000D5 UM000E5 UM000F5 UM00105	Offset value	0	To apply the setting, "Offset/gain processing" must be enabled. Setting range: -3000 to +3000 (specified with a signed integer)
UM00096 UM000A6 UM000B6 UM000C6 UM000D6 UM000E6 UM000F6 UM00106	Gain value	10000	To apply the setting, "Offset/gain processing" must be enabled. Setting range: +9000 to +11000: 0.9x to 1.1x (specified with a signed integer)
UM00097 UM000A7 UM000B7 UM000C7 UM000D7 UM000E7 UM000F7 UM00107	Upper limit of scale	10000	To apply the setting, "Scale conversion" must be enabled. Setting range: -30000 to +30000 (specified with a signed integer)
UM00098 UM000A8 UM000B8 UM000C8 UM000D8 UM000E8 UM000F8 UM00108	Lower limit of scale	0	To apply the setting, "Scale conversion" must be enabled. Setting range: -30000 to +30000 (specified with a signed integer)
UM00099 UM000A9 UM000B9 UM000C9 UM000D9 UM000E9 UM000F9 UM00109	High limit alarm switch-on value	0	To apply the setting, "Limit alarm" must be enabled. Setting range: -31250 to +31250 (specified with a signed integer)
UM0009A UM000AA UM000BA UM000CA UM000DA UM000EA UM000FA UM0010A	High limit alarm switch-off value	0	
UM0009B UM000AB UM000BB UM000CB UM000DB UM000EB UM000FB UM0010B	Low limit alarm switch-off value	0	

Unit memory address	Name	Default	Setting range
UM0009C UM000AC UM000BC UM000CC UM000DC UM000EC UM000FC UM0010C	Low limit alarm switch-on value	0	

Maximum and minimum value hold areas (per channel)

To monitor a value, "Maximum and minimum value hold" must be enabled.

The unit memory addresses are listed in ascending order for the supported channels (e.g. first unit memory address applies to channel 0, second to channel 1 etc.).

Unit memory address	Name	Default	Description
UM00180 UM00181 UM00182 UM00183 UM00184 UM00185 UM00186 UM00187	Maximum hold value	0	Maximum range: -31250 to +31250 (specified with a signed integer)
UM00188 UM00189 UM0018A UM0018B UM0018C UM0018D UM0018E UM0018F	Minimum hold value	0	

Buffer areas for AFP7AD4H (per channel)

Unit memory address	Channel	Default	Description
UM00800–UM02F0F	0	0	10000 words per channel Maximum range: -31250 to +31250 (specified with a signed integer)
UM03000–UM0570F	1	0	
UM05800–UM07F0F	2	0	
UM08000–UM0A70F	3	0	

Buffer areas for AFP7AD8 (per channel)

Unit memory address	Channel	Default	Description
UM00400–UM0233F	0	0	8000 words per channel Maximum range: -31250 to +31250 (specified with a signed integer)
UM02340–UM0427F	1	0	
UM04280–UM061BF	2	0	
UM061C0–UM080FF	3	0	
UM08100–UM0A03F	4	0	
UM0A040–UM0BF7F	5	0	
UM0BF80–UM0DEBF	6	0	
UM0DEC0–UM0FDFF	7	0	

8.5 Dimensions

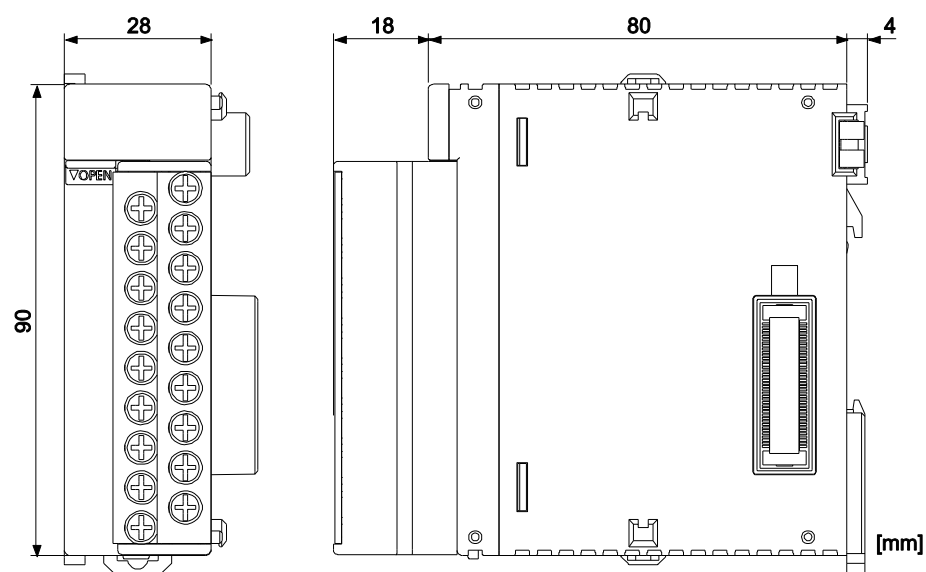



North America

Europe

Asia Pacific

China

Japan

Panasonic Electric Works

Please contact our Global Sales Companies in:

Europe		
▶ Headquarters	Panasonic Electric Works Europe AG	Robert-Koch-Straße 100, 85521 Ottobrunn, Tel. +49 89 45354-1000, Fax +49 89 45354-2111, www.panasonic-electric-works.com
▶ Austria	Panasonic Electric Works Austria GmbH	Josef Madersperger Str. 2, 2362 Biedermannsdorf, Tel. +43 (0) 2236-26846, Fax +43 (0) 2236-46133 www.panasonic-electric-works.at
	Panasonic Industrial Devices Materials Europe GmbH	Ennsbahnstraße 30, 4470 Enns, Tel. +43 (0) 7223 883, Fax +43 (0) 7223 88333, www.panasonic-electronic-materials.com
▶ Benelux	Panasonic Electric Works Sales Western Europe B.V.	De Rijn 4, (Postbus 211), 5684 PJ Best, (5680 AE Best), Netherlands, Tel. +31 (0) 499 372727, Fax +31 (0) 499 372185, www.panasonic-electric-works.nl
▶ Czech Republic	Panasonic Electric Works Europe AG, organizační složka	Administrative centre PLATINIUM, Veverří 3163/111, 616 00 Brno, Tel. +420 541 217 001, Fax +420 541 217 101, www.panasonic-electric-works.cz
▶ France	Panasonic Electric Works Sales Western Europe B.V.	Succursale française, 10, rue des petits ruisseaux, 91370 Verrières Le Buisson, Tél. +33 (0) 1 6013 5757, Fax +33 (0) 1 6013 5758, www.panasonic-electric-works.fr
▶ Germany	Panasonic Electric Works Europe AG	Robert-Koch-Straße 100, 85521 Ottobrunn, Tel. +49 (0) Tel. +49 (0) 45354-1000, Fax +49 (0) 45354-2111, www.panasonic-electric-works.de
▶ Hungary	Panasonic Electric Works Europe AG	Magyarországi Közvetlen Kereskedelmi Képviselet, 1117 Budapest, Neumann János u. 1., Tel. +43 2236 26846-25, Mobile: +36 20 264 9896, Fax +43 2236 46133, www.panasonic-electric-works.hu
▶ Ireland	Panasonic Electric Works UK Ltd.	Irish Branch Office, Dublin, Tel. +353 (0) 14600969, Fax +353 (0) 14601131, www.panasonic-electric-works.co.uk
▶ Italy	Panasonic Electric Works Italia srl	Via del Commercio 3-5 (Z.I. Ferlina), 37012 Bussolengo (VR), Tel. +39 0456752711, Fax +39 0456700444, www.panasonic-electric-works.it
▶ Nordic Countries	Panasonic Electric Works Europe AG Panasonic Eco Solutions Nordic AB	Filial Nordic, Knarrarnäsgatan 15, 164 40 Kista, Sweden, Tel. +46 859476680, Fax +46 859476690, www.panasonic-electric-works.se
▶ Poland	Panasonic Electric Works Polska sp. z o.o	Jungmansgatan 12, 21119 Malmö, Tel. +46 40 697 7000, Fax +46 40 697 7099, www.panasonic-fire-security.com
▶ Spain	Panasonic Electric Works España S.A.	ul. Wołoska 9A, 02-583 Warszawa, Tel. +48 22 338-11-33, Fax +48 22 338-12-00, www.panasonic-electric-works.pl
▶ Switzerland	Panasonic Electric Works Schweiz AG	Barajas Park, San Severo 20, 28042 Madrid, Tel. +34 913293875, Fax +34 913292976, www.panasonic-electric-works.es
▶ United Kingdom	Panasonic Electric Works UK Ltd.	Grundstrasse 8, 6343 Rotkreuz, Tel. +41 (0) 41 7997050, Fax +41 (0) 41 7997055, www.panasonic-electric-works.ch
		Sunrise Parkway, Linford Wood, Milton Keynes, MK14 6 LF, Tel. +44 (0) 1908 231555, Fax +44 (0) 1908 231599, www.panasonic-electric-works.co.uk
North & South America		
▶ USA	Panasonic Industrial Devices Sales Company of America	629 Central Avenue, New Providence, N.J. 07974, Tel. 1-908-464-3550, Fax 1-908-464-8513, www.pewa.panasonic.com
Asia Pacific/China/Japan		
▶ China	Panasonic Electric Works Sales (China) Co. Ltd.	Level 2, Tower W3, The Towers Oriental Plaza, No. 2, East Chang An Ave., Dong Cheng District, Beijing 100738, Tel. +86-10-5925-5988, Fax +86-10-5925-5973
▶ Hong Kong	Panasonic Industrial Devices Automation Controls Sales (Hong Kong) Co., Ltd.	RM1205-9, 12/F, Tower 2, The Gateway, 25 Canton Road, Tsimshatsui, Kowloon, Hong Kong, Tel. +852-2956-3118, Fax +852-2956-0398
▶ Japan	Panasonic Corporation	1048 Kadoma, Kadoma-shi, Osaka 571-8686, Japan, Tel. +81-6-6908-1050, Fax +81-6-6908-5781, www.panasonic.net
▶ Singapore	Panasonic Industrial Devices Automation Controls Sales Asia Pacific	300 Beach Road, #16-01 The Concourse, Singapore 199555, Tel. +65-6390-3811, Fax +65-6390-3810