

## PROGRAMMABLE CONTROLLER

# FP7 Motion Control Unit

# User's Manual

---

[Applicable models]

FP7 Motion Control Unit (EtherCAT type)

- 16-axis type (Product number AFP7MC16EC)
- 32-axis type (Product number AFP7MC32EC)
- 64-axis type (Product number AFP7MC64EC)

# SAFETY PRECAUTIONS

To prevent accidents or personal injuries, please be sure to comply with the following items.  
Prior to installation, operation, maintenance and check, please read this manual carefully for proper use.  
Before using, please fully understand the knowledge related to the equipment, safety precautions and all other precautions.

Safety precautions are divided into two levels in this manual: Warning and Caution.



**WARNING** Incorrect operation may lead to death or serious injury.

- Take appropriate safety measures to the external circuit of the product to ensure the security of the whole system in case of abnormalities caused by product failure or external.
- Do not use this product in areas with inflammable gases.  
Otherwise it may lead to an explosion.
- Do not put this product into a fire.  
Otherwise it could cause damage to the battery or other electronic parts.



**CAUTION** Incorrect operation may lead to injury or material loss.

- To prevent the excessive exothermic heat or smoke generation of the product, a certain margin is required for guaranteed characteristics and performance ratings of relative products.
- Do not decompose or transform it.  
Otherwise it will lead to the excessive exothermic heat or smoke generation of the product.
- Do not touch terminal blocks during power-on.  
Otherwise it may result in an electric shock.
- Set an emergency stop and interlock circuit in the external devices.
- Connect wires and connectors reliably.  
Otherwise it may lead to the excessive exothermic heat or smoke generation of the product.
- Do not allow foreign matters such as liquid, flammable materials, metals to go into the inside of the product.  
It could cause excessive exothermic heat or smoke generation.
- Do not undertake construction (such as connection and disconnection) while the power supply is on.  
It could lead to an electric shock.
- If the equipment is used in a manner not specified by the Panasonic, the protection provided by the equipment may be impaired.
- This product has been developed/produced for industrial use only.

## Description on Copyright and Trademarks

- The copyright of this manual is owned by Panasonic Industrial Devices SUNX Co., Ltd.
- Unauthorized reproduction of this manual is strictly prohibited.
- Windows is a registered trademark of Microsoft Corporation in the U.S. and other countries.
- EtherCAT® is a registered trademark and patented technology, licensed by Beckhoff Automation GmbH, Germany.
- Other company and product names are trademarks or registered trademarks of their respective companies.

# Introduction

Thank you for buying a Panasonic product. Before you use the product, please carefully read the installation instructions and the user's manual, and understand their contents in detail to use the product properly.

## Types of Manual

- There are different types of user's manual for the FP7 series, as listed below. Please refer to a relevant manual for the unit and purpose of your use.
- The manuals can be downloaded on our website:  
[https://industrial.panasonic.com/ac/e/dl\\_center/manual/](https://industrial.panasonic.com/ac/e/dl_center/manual/)

Unit name or purpose of use	Manual name	Manual code
FP7 Power Supply Unit	FP7 CPU Unit User's Manual (Hardware)	WUME-FP7CPUH
FP7 CPU Unit	FP7 CPU Unit Command Reference Manual	WUME-FP7CPUPGR
	FP7 CPU Unit User's Manual (Logging Trace Function)	WUME-FP7CPULOG
	FP7 CPU Unit User's Manual (Security Function)	WUME-FP7CPUSEC
	Instructions for Built-in LAN Port	FP7 CPU Unit Users Manual (LAN Port Communication)
FP7 CPU Unit User's Manual (Ethernet Add-ons)		WUME-FP7CPUETEX
FP7 CPU Unit User's Manual (EtherNet IP communication)		See our web site.
FP7 Web Server Function Manual		WUME-FP7WEB
Instructions for Built-in COM Port	FP7 series User's Manual (SCU communication)	WUME-FP7COM
FP7 Extension Cassette (Communication) (RS-232C/RS-485 type)		
FP7 Extension Cassette (Communication) (Ethernet type)	FP7 series User's Manual (Communication cassette Ethernet type)	WUME-FP7CCET
FP7 Extension (Function) Cassette Analog Cassette	FP7 Analog Cassette User's Manual	WUME-FP7FCA
FP7 Digital Input/Output Unit	FP7 Digital Input/Output Unit User's Manual	WUME-FP7DIO
FP7 Analog Input Unit	FP7 Analog Input Unit User's Manual	WUME-FP7AIH
FP7 Analog Output Unit	FP7 Analog Output Unit User's Manual	WUME-FP7AOH

## Types of Manual

---

Unit name or purpose of use	Manual name	Manual code
FP7 Thermocouple Multi-analog Input Unit	FP7 Thermocouple Multi-analog Input Unit FP7 RTD Input Unit User's Manual	WUME-FP7TCRTD
FP7 RTD Input Unit		
FP7 Multi Input/Output Unit	FP7 Multi Input/Output Unit User's Manual	WUME-FP7MXY
FP7 High-speed counter unit	FP7 High-speed Counter Unit User's Manual	WUME-FP7HSC
FP7 Pulse Output Unit	FP7 Pulse Output Unit User's Manual	WUME-FP7PG
FP7 Positioning Unit	FP7 Positioning Unit User's Manual	WUME-FP7POSP
FP7 Motion Control Unit	FP7 Motion Control Unit User's Manual	WUME-FP7MCEC
FP7 Serial Communication Unit	FP7 series User's Manual (SCU communication)	WUME-FP7COM
PHLS System	PHLS System User's Manual	WUME-PHLS
Programming Software FPWIN GR7	FPWIN GR7 Introduction Guidance	WUME-FPWINGR7

## Items Requiring Particular Attention

---

When using FP7 MC Unit in combination with Servo Amplifier A6B/A5B, please note the followings.

### ■ Wiring of Power Supply

To avoid influence of noise, keep the power supply systems of servo amplifier and PLC separate.

### ■ Connection of Over Limit Input

- In the system using FP7 MC Unit and Servo Amplifier A6B/A5B, limit switches are connected to the general-purpose inputs (SI-MON3 and SI-MON4) of Servo Amplifier A6B/A5B to enable the control by a high-order PLC (FP7 MC Unit).
- The POT/NOT input of the servo amplifier A6B/A5B cannot be used as the limit input of a high-order PLC (FP7 MC Unit).
- For using the general-purpose inputs of the servo amplifier A6B/A5B (SI-MON3 and SI-MON4) as the limit input of a high-order PLC (FP7 MC Unit), parameters of the servo amplifier A6B/A5B and FP7 MC need to be changed. For details, refer to "4.5 Connection of Limit and Near Home Switches".

### ■ Operation when home return operation is performed

For the home return methods which are based on the home position (Z phase) (i.e. DOG method 1, DOG method 3, Limit method 1, Z phase method and Stop-on-contact method 2), the home return operation after shifting to the creep speed is controlled by the servo amplifier A6B/A5B. During this operation, the high-order PLC (FP7 MC Unit) cannot control the operation. Please design and evaluate the system to avoid any danger even after shifting to the creep speed.

## Glossary

To make explanations simple, abbreviations are used for the following terms.

Abbreviation	Name	Description
FP7 MC Unit	FP7 Motion Control Unit	The product name of the unit described in this manual.
CMI	Control Motion Integrator	The software for setting parameters of FP7 MC Unit.

As for the following terms, they are expressed differently in software, manuals and specification concerning FP7 MC Unit and Servo Amplifiers A6B/A5B.

FP7 MC Unit	A6B/A5B	Description
Station address	Station alias	This shows the unit numbers allocated to slaves on EtherCAT network. The left two terms have the same meaning.
-	General-purpose monitor input	Five inputs of symbols SI-MON1 to SI-MON5 are allocated on the A6B/A5B side.
General-purpose input	-	On the FP7 MC Unit side, eight signals of A6B/A5B are treated as "general-purpose input" and can be monitored through the unit memory.  NOT, POT, HOME, SI-MON1 to SI-MON5  For using it in combination with FP7 MC Unit, SI-MON3 and SI-MON4 are used as limit inputs. NOT and POT are not used.
-	General-purpose output	On the A6B/A5B side, one output of symbol EX-OUT1 is allocated.
General-purpose output	-	On the FP7 MC Unit side, one signal to A6B/A5B is treated as "general-purpose output" and can be written through the unit memory. EX-OUT1

---

# Table of Contents

<b>1. Unit Functions and Restrictions .....</b>	<b>1-1</b>
1.1 Functions of Motion Control Unit .....	1-2
1.1.1 Functions of Unit .....	1-2
1.1.2 List of Models .....	1-3
1.2 Restrictions .....	1-4
1.2.1 Supported Functions .....	1-4
1.2.2 Restrictions by Power Consumption in FP7 System.....	1-5
1.2.3 Applicable Versions of FPWIN GR7 and FP7 Units.....	1-5
1.3 System Configuration.....	1-6
1.3.1 Example of System Configuration.....	1-6
1.3.2 Type of Software .....	1-7
1.4 Mechanism of Processing.....	1-8
1.4.1 Schematic View.....	1-8
1.4.2 Operation When Power Supply Turns On.....	1-9
1.4.3 Start/Stop by User Programs .....	1-9
<b>2. Names and Functions of Parts .....</b>	<b>2-1</b>
2.1 Names and Functions of Parts .....	2-2
2.1.1 Names and Functions of Parts.....	2-2
2.1.2 Operation Monitor LEDs.....	2-3
2.1.3 ESM (State Transition Diagram) .....	2-4
<b>3. Installation and Wiring.....</b>	<b>3-1</b>
3.1 Setting of Node Address (ID) .....	3-2

3.1.1	Type of Setting Method .....	3-2
3.1.2	Settings of Servo Amplifier MINAS A6B/A5B.....	3-2
3.1.3	Setting by Software CMI.....	3-4
3.1.4	Node Address Setting and State Confirmation .....	3-7
3.2	Connection of Network .....	3-11
3.2.1	Wiring .....	3-11
3.2.2	Precautions on Wiring .....	3-11
3.3	Connection of Servo Amplifier .....	3-13
3.3.1	Connection of Input Signals .....	3-13
<b>4.</b>	<b>Basic Procedure .....</b>	<b>4-1</b>
4.1	Section Details .....	4-2
4.2	Registration in I/O Map .....	4-3
4.2.1	Creation of I/O Map .....	4-3
4.2.2	Download of I/O Map.....	4-4
4.2.3	Storage of I/O map .....	4-4
4.2.4	Confirmation of I/O Allocation .....	4-4
4.2.5	Confirmation of Slot Numbers .....	4-5
4.3	Setting of Used Axes .....	4-6
4.3.1	Registration of Used Axes.....	4-6
4.4	Setting of Network Configuration .....	4-10
4.4.1	Registration of Slaves (Offline) .....	4-10
4.4.2	Registration of Slaves (Online) .....	4-12
4.4.3	Setting of Station Addresses and Axis Numbers .....	4-14
4.4.4	Download to FP7 MC Unit.....	4-17
4.4.5	Restarting Power Supplies and Checking Communication State .....	4-19
4.5	Connection of Limit and Near Home Switches.....	4-21
4.5.1	Connection of Input Signals .....	4-21
4.5.2	Pin Assignment Setting of Servo Amplifier.....	4-22
4.5.3	Checking Servo Amplifier Input State .....	4-24
4.5.4	Settings of FP7 MC Unit.....	4-25



---

4.5.5	Download to FP7 MC Unit.....	4-26
4.5.6	Checking Input State.....	4-26
4.6	Saving and Managing Files.....	4-27
4.6.1	File Type.....	4-27
4.6.2	Saving as CMI Files .....	4-27
4.6.3	Export to CSV Files.....	4-28
<b>5.</b>	<b>Settings of FP7 MC Unit Using CMI Tool .....</b>	<b>5-1</b>
5.1	FP7 MC Unit Common Settings .....	5-2
5.1.1	FP7 MC Unit Common Settings Dialog Box .....	5-2
5.1.2	FP7 MC Unit Common Settings Parameters .....	5-3
5.2	Axis Parameter Settings.....	5-6
5.2.1	Setting by CMI.....	5-6
5.2.2	Axis Parameters (Basic Setup) .....	5-7
5.2.3	Axis Parameters (Options).....	5-8
5.2.4	Axis Parameters (Operation).....	5-10
5.3	Positioning Table Setting .....	5-13
5.3.1	Construction of Positioning Tables.....	5-13
5.3.2	Operation Patterns and Tables .....	5-16
5.4	Synchronous Parameter and Cam Pattern Settings .....	5-17
5.4.1	Synchronous Parameter Settings .....	5-17
5.4.2	Cam Pattern Setting.....	5-18
5.5	Confirmation of Setting Contents .....	5-19
5.5.1	Check on Parameter Data.....	5-19
5.5.2	Comparison of Parameter Information .....	5-20
5.6	Transfer of Parameters .....	5-21
5.6.1	Writing Parameters to Unit.....	5-21

---

**6. Data Transfer to MC Unit and Test Operation..... 6-1**

6.1 Before Turning On the Power ..... 6-2

6.2 Power-on and Power-off Sequences ..... 6-3

    6.2.1 Procedure for Turning On the Power ..... 6-3

    6.2.2 Procedure for Turning Off the Power ..... 6-3

6.3 Checking While the Power is ON..... 6-4

    6.3.1 Items to Check When the Power is ON..... 6-4

    6.3.2 Checking Network Communication State..... 6-5

    6.3.3 Checking the Safety Circuit by the PLC Unit..... 6-6

    6.3.4 Checking the Operation of Near Home Input..... 6-7

    6.3.5 Checking Rotating and Moving Directions and Moving Distance ..... 6-7

6.4 Monitor Function of CMI ..... 6-8

    6.4.1 Status Monitor ..... 6-8

    6.4.2 Data Monitor..... 6-10

6.5 Tool Operation Function of CMI..... 6-12

    6.5.1 Tool Operation Function..... 6-12

    6.5.2 Serve ON/OFF with Tool Operation Function ..... 6-14

    6.5.3 JOG Operation with Tool Operation Function ..... 6-16

    6.5.4 Home Return by Tool Operation Function ..... 6-18

    6.5.5 Positioning by Tool Operation Function ..... 6-20

    6.5.6 Teaching by Tool Operation Function ..... 6-23

**7. Creation of User Programs ..... 7-1**

7.1 How to Create User Programs..... 7-2

    7.1.1 Basic Configuration of Program ..... 7-2

7.2 Overview of Programs ..... 7-4

    7.2.1 Reading Data From Input Control Area..... 7-4

    7.2.2 Servo ON/OFF Control Program..... 7-5

    7.2.3 Start Enabled Program..... 7-6

    7.2.4 Each Control Programs ..... 7-6

---

7.2.5	Writing Data to Output Control Area .....	7-7
7.3	Precautions on Programming.....	7-8
7.3.1	Turning Off Power Supply Clears Contents in Unit Memories.....	7-8
7.3.2	Operation Cannot be Switched Once One Operation Has Started.....	7-8
7.3.3	Operation When PLC Mode Changes from RUN to PROG.....	7-8
<b>8.</b>	<b>Automatic Operation (Position Control) .....</b>	<b>8-1</b>
8.1	Basic Operation .....	8-2
8.1.1	Patterns of Position Control .....	8-2
8.1.2	Setting and Operation of E-point Control .....	8-4
8.1.3	Setting and Operation of P-point Control .....	8-6
8.1.4	Setting and Operation of C-point Control .....	8-8
8.1.5	Setting and Operation of J-point Control.....	8-10
8.2	Interpolation Control.....	8-12
8.2.1	Type of Interpolation Control (2-Axis Interpolation) .....	8-12
8.2.2	Setting and Operation of 2-Axis Linear Interpolation .....	8-14
8.2.3	Setting and Operation of 2-Axis Circular Interpolation.....	8-16
8.2.4	Type of Interpolation Control (3-axis Interpolation).....	8-18
8.2.5	Setting and Operation of 3-Axis Linear Interpolation .....	8-20
8.2.6	Setting and Operation of 3-Axis Spiral Interpolation .....	8-22
8.3	Repeat Function.....	8-24
8.3.1	Overview of Repeat Operation.....	8-24
8.3.2	Stop Operation During Repeat Operation.....	8-25
8.3.3	Setting and Operation of Repeat.....	8-26
8.4	Target Speed Change Function .....	8-28
8.4.1	Description of Functions.....	8-28
8.4.2	Setting Procedures and Operations (Speed Direct Specification Method).....	8-29
8.4.3	Setting Procedures and Operations (Ratio Specification Method) .....	8-33
8.4.4	Sample Program (Target Speed Change) .....	8-34
8.5	Movement Amount Change Function .....	8-35
8.5.1	Description of Functions.....	8-35

---

8.5.2	Setting Procedures and Operations .....	8-36
8.5.3	Sample Program .....	8-40
8.6	Dwell Time.....	8-41
8.7	Auxiliary Output Code and Auxiliary Output Contact.....	8-42
8.8	Sample Programs.....	8-44
8.8.1	Sample Programs (E-point, P-point and C-point Controls) .....	8-44
8.8.2	Precautions on Programming.....	8-46
8.9	Reconstruction of Positioning Data by User Programs .....	8-47
8.9.1	Reconstruction of Positioning Data .....	8-47
8.9.2	Procedure of Rewriting Positioning Data .....	8-48
8.9.3	Sample Program (Rewriting Positioning Tables) .....	8-54
8.10	Use of Extended Positioning Table.....	8-56
8.10.1	Use of Extended Positioning Table .....	8-56
8.10.2	Sample Program (Extended Table).....	8-61

## **9. Automatic Operation (Synchronous Control)..... 9-1**

9.1	Synchronous Control .....	9-2
9.1.1	Overview of Synchronous Control.....	9-2
9.2	Settings for Master and Slave Axes .....	9-4
9.2.1	Selection of Master Axis and Settings.....	9-4
9.2.2	Selection of Slave Axes and Settings .....	9-5
9.2.3	Unit Type and Number of Axes .....	9-5
9.2.4	Setting by CMI.....	9-6
9.3	Start and Cancel of Synchronous Control.....	9-7
9.3.1	Start and Cancel of Synchronous Control.....	9-7
9.3.2	Precautions When Canceling or Starting Synchronous Control .....	9-9
9.4	Electronic Gear Function .....	9-14
9.4.1	Overview of Electronic Gear Function.....	9-14
9.4.2	Types and Contents of Setting Parameters .....	9-15
9.4.3	Gear Ratio Changes while in Operation.....	9-16

---

9.5	Electronic Clutch Function .....	9-18
9.5.1	What is Electronic Clutch Function? .....	9-18
9.5.2	Types and Contents of Setting Parameters .....	9-19
9.5.3	Trigger Types for Electronic Clutch .....	9-21
9.5.4	Connection Method of Electronic Clutch .....	9-23
9.5.5	Phase Specification Clutch OFF Function .....	9-25
9.6	Electronic Cam Function .....	9-27
9.6.1	Overview of Electronic Cam Function .....	9-27
9.6.2	Types and Contents of Setting Parameters .....	9-29
9.6.3	Cam Pattern Setting Method .....	9-30
9.6.4	Editing Cam Patterns by User Programs .....	9-37
9.6.5	Advance Angle Correction Function .....	9-53
<b>10.</b>	<b>Manual Operation (JOG Operation).....</b>	<b>10-1</b>
10.1	Settings and Operations of JOG Operation .....	10-2
10.2	Changing Speed During JOG Operation .....	10-4
10.3	Setting and Operation of JOG Inching Operation .....	10-8
10.4	Sample Programs .....	10-10
10.4.1	Sample Program (JOG Operation).....	10-10
10.4.2	Precautions on Programming.....	10-12
<b>11.</b>	<b>Manual Operation (Home Return).....</b>	<b>11-1</b>
11.1	Types of Home Return .....	11-2
11.2	Operation of Home Return .....	11-10
11.3	Sample Programs .....	11-12
11.3.1	Sample Program (Home Return) .....	11-12
11.3.2	Precautions on Programming.....	11-14

<b>12. Stop Functions</b> .....	<b>12-1</b>
12.1 Type of Stop Functions.....	12-2
12.1.1 Type of Stop Functions .....	12-2
12.1.2 Characteristics of Pause Function .....	12-4
12.1.3 Stop Operation During Interpolation Control .....	12-6
12.1.4 Stop Operation During Synchronous Control.....	12-6
12.2 Settings Related to Stop Function .....	12-7
12.2.1 MC Common Settings .....	12-7
12.2.2 Axis Parameter.....	12-8
12.3 Operation During Stop.....	12-9
<b>13. Supplementary Functions</b> .....	<b>13-1</b>
13.1 Software Limit.....	13-2
13.2 Current Value Update.....	13-3
13.3 Home Coordinates.....	13-5
13.4 Movement Amount Automatic Check.....	13-7
13.5 Completion Width .....	13-9
13.6 Monitor Value Judgement.....	13-10
13.6.1 Torque Judgement .....	13-11
13.6.2 Actual Speed Judgement .....	13-13
13.7 Torque Limit .....	13-16
13.7.1 Restrictions on Torque Limit.....	13-17
13.8 EtherCAT Communication Setting .....	13-18
13.8.1 EtherCAT Configurator.....	13-18
13.8.2 Device Editor .....	13-19
13.8.3 Overview of PDO Mapping.....	13-20
13.8.4 Change of PDO Mapping .....	13-22
13.9 SDO/PDO Communication .....	13-25

---

13.9.1 SDO Communication .....	13-25
13.9.2 PDO Communication .....	13-43
13.10 ESI Manager .....	13-45
13.11 Connection with Slave SL-VGU1-EC .....	13-46
13.11.1 Registration of Slaves .....	13-46
13.11.2 Confirmation of Unit Memory Numbers .....	13-47
13.12 Connection with Slave Encoder Input Device .....	13-48
13.12.1 Operation of Encoder Input Device .....	13-48
13.12.2 Configuration .....	13-49
13.12.3 Monitor Operation .....	13-51
13.13 EC Packet Monitor Function .....	13-52
13.13.1 Overview of Function .....	13-52
13.13.2 Stored Files .....	13-52
13.13.3 Handling of SD Memory Card .....	13-53
13.13.4 How to Set .....	13-54
13.13.5 How to Execute .....	13-55
13.14 How to Delay EtherCAT Communication Startup after Power ON .....	13-56
<b>14. CMTimeChart Monitor .....</b>	<b>14-1</b>
14.1 Overview of Function .....	14-2
14.2 Registration of Devices .....	14-4
14.3 Trigger Condition Setting .....	14-6
14.3.1 Setting Procedure of Trigger Conditions .....	14-6
14.3.2 Trigger Condition Setting (Sampling) .....	14-8
14.3.3 Trigger Condition Setting (Trigger Mode/Trigger Position) .....	14-9
14.3.4 Trigger Condition Setting (Trigger Condition) .....	14-10
14.4 Download to Setting Data to the Unit .....	14-12
14.5 Start and Stop of Logging Operation .....	14-13
14.5.1 Procedures of Start and Stop by "CMTimeChart" .....	14-13

---

14.5.2 Start/Stop by User Programs .....	14-15
14.5.3 Logging Operation Diagram .....	14-17
14.6 Upload of Logging Data (Time Chart) .....	14-20
14.6.1 Procedure of Uploading Logging Data .....	14-20
14.6.2 Settings for Time Chart Display Area .....	14-22
14.7 Storage of CMTimeChart Data .....	14-25
14.8 Storage in SD Memory Card.....	14-26
14.8.1 Storing Logging Data.....	14-26
14.8.2 Setting When Using SD Memory Cards.....	14-27
<b>15. Troubleshooting.....</b>	<b>15-1</b>
15.1 Errors and Warnings.....	15-2
15.1.1 Errors and Warnings .....	15-2
15.1.2 Checking and Clearing by CMI .....	15-2
15.1.3 Clearing Errors/Warnings Using User Programs .....	15-3
15.1.4 Error and Warning Logs .....	15-4
15.2 Error Recovery Process.....	15-5
15.2.1 Overview.....	15-5
15.3 Error Code Table.....	15-6
15.3.1 AMP Errors (From 00FF 0000H).....	15-6
15.3.2 System Errors (From 00F0 1000H).....	15-13
15.3.3 AMP Communication Errors (From 00F0 2000H).....	15-14
15.3.4 Axis Operation Errors (From 00F0 3000H) .....	15-15
15.3.5 Setting Value Errors (From 00F0 4000H) .....	15-18
15.3.6 Synchronous Parameter Setting Errors (From 00F0 5000H).....	15-22
15.3.7 Other Errors (From 00F0 F000H).....	15-25
15.4 Warning Code Table.....	15-26
15.4.1 AMP Warnings (From 00A0 0000H) .....	15-26
15.4.2 Unit Warnings (From 00B0 0000H).....	15-28



---

<b>16. Specifications .....</b>	<b>16-1</b>
16.1 Specifications.....	16-2
16.1.1 General Specifications .....	16-2
16.1.2 EtherCAT Communication Specifications .....	16-3
16.1.3 Performance Specifications .....	16-4
16.2 I/O Allocation .....	16-8
16.3 Whole Configuration of Unit Memories .....	16-10
16.4 Unit Memories (Input and Output Control Areas).....	16-13
16.4.1 Configuration of Input Control Area.....	16-13
16.4.2 List of Input Control Area Functions.....	16-14
16.4.3 Configuration of Output Control Area.....	16-26
16.4.4 List of Output Control Area Functions.....	16-27
16.5 Unit Memories (Common Area).....	16-35
16.5.1 Configuration of Common Area.....	16-35
16.5.2 Setting Parameter Control Area .....	16-36
16.5.3 Operation Speed Rate Area.....	16-36
16.5.4 Axis Group Setting Area.....	16-37
16.5.5 Current Value Update Data Area .....	16-38
16.5.6 Torque Limit Area.....	16-40
16.5.7 Actual Speed Monitor Area .....	16-41
16.5.8 Positioning Control Starting Table Number Setting Area.....	16-41
16.5.9 Positioning Control Area .....	16-42
16.5.10 Error Annunciation and Clear Area .....	16-43
16.5.11 Warning Annunciation and Clear Area.....	16-45
16.5.12 Synchronous Control Monitor Area .....	16-47
16.5.13 System Operation Setting Area.....	16-48
16.5.14 Time Chart Function Operation Setting/Annunciation Area .....	16-49
16.5.15 ESM Switch Control Area.....	16-51
16.6 Unit Memories (Each Axis Information Area).....	16-52
16.6.1 Configuration of Each Axis Information Area .....	16-52
16.6.2 Each Axis Information & Monitor Area .....	16-53

---

16.7 Unit Memories (Each Axis Setting Area).....	16-56
16.7.1 Configuration of Each Axis Setting Area .....	16-56
16.7.2 Configuration of Parameter Setting Area .....	16-57
16.7.3 Parameter Setting Area.....	16-58
16.7.4 Configuration of Positioning Data Setting Area.....	16-66
16.8 Unit Memories (Synchronous Control Setting Area).....	16-75
16.8.1 Configuration of Synchronous Control Setting Area .....	16-75
16.8.2 Synchronous Control Setting Area .....	16-76
16.8.3 Electronic Gear Setting Area.....	16-77
16.8.4 Clutch Setting Area .....	16-78
16.8.5 Electronic Cam Setting Area .....	16-80
16.9 Unit Memories (Positioning Operation Change Setting Area) .....	16-82
16.9.1 Configuration of Positioning Operation Change Setting Area.....	16-82
16.9.2 Positioning Speed/Movement Amount Change Parameter .....	16-83
16.10 Unit Memories (Cam Pattern Editing Area).....	16-84
16.10.1 Configuration of Cam Pattern Editing Area .....	16-84
16.10.2 Cam Pattern Setting Area .....	16-85
16.10.3 Cam Pattern Editing Execution Area.....	16-92
16.11 Unit Memories (SDO/PDO Communication Area).....	16-94
16.11.1 Configuration of SDO/PDO Communication Area.....	16-94
16.11.2 SDO Communication Area .....	16-95
16.11.3 PDO Communication Area [RxPDO (Master -> Slave Devices)] ..	16-100
16.11.4 PDO Communication Area [TxPDO (Master <- Slave Devices)] ..	16-101
16.12 Reference "ASCII Codes" .....	16-103
16.13 Dimensions.....	16-104

# 1

## Unit Functions and Restrictions

## 1.1 Functions of Motion Control Unit

---

### 1.1.1 Functions of Unit

---

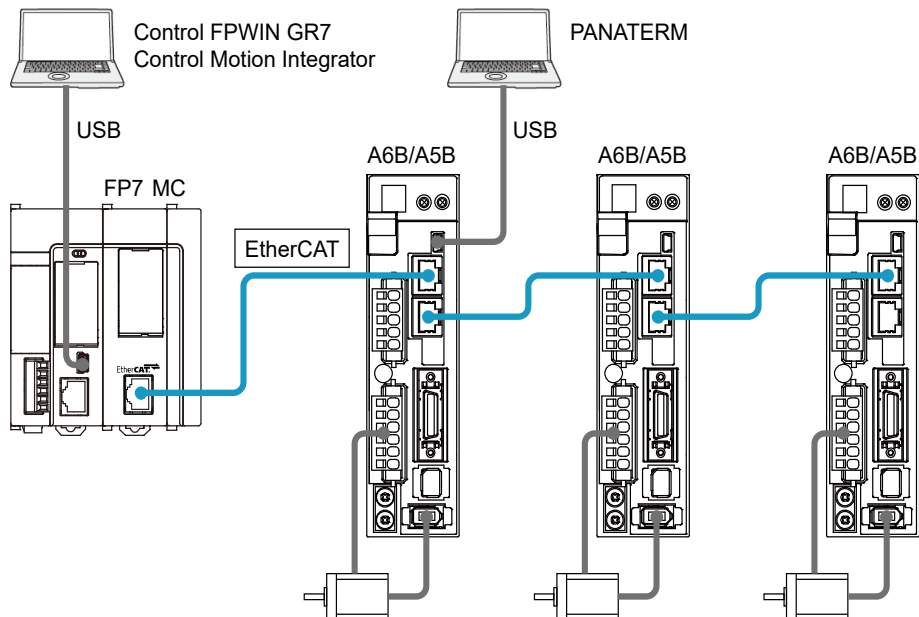

#### ■ Controlling Servo Motor MINAS A6B/A5B series through EtherCAT

FP7 Motion Control Unit (hereafter FP7 MC Unit) adopts EtherCAT communication and controls servo motors. It achieves wiring saving by network connection and high-speed control.

(Note): EtherCAT® is a registered trademark of Beckhoff Automation GmbH in Germany and a technology protected by a patent.

#### ■ Setting using dedicated software "Control Motion Integrator"

Dedicated software "Control Motion Integrator" (sold separately) is provided for easily configuring the setting of EtherCAT communication and parameters of position control.

## 1.1.2 List of Models

### ■ Control unit

Product name	Max. number of control axes	Product no.
FP7 Motion Control Unit (Abbreviated name: FP7 MC Unit)	16 axes/unit	AFP7MC16EC
	32 axes/unit	AFP7MC32EC
	64 axes/unit	AFP7MC64EC

### ■ Related software

Product name	Application	Product no.
Programming software Control FPWIN GR7	This software is used for configuring the whole FP7 system and creating user programs.	For the latest information, see our web site.
Software Control Motion Integrator	This software is used for configuring FP7 MC Unit and monitoring the state. <ul style="list-style-type: none"> <li>● EtherCAT communication parameters</li> <li>● Setting of positioning parameters</li> <li>● Setting of positioning tables</li> </ul>	For the latest information, see our web site.
	Key Unit	For installing a USB port (Note 3)
Setup support software PANATERM	This software is used for setting parameters and monitoring the states of Servo Amplifier A6B/A5B series.	For the latest information, see our web site.

(Note 1): For the latest information on Control FPWIN GR7 and Control Motion integrator, see the following web site.  
<https://industrial.panasonic.com/ac/e/fasys/plc/software/fpwingr7/index.jsp>

(Note 2): For the latest information on PANATERM, see the following web site.  
<https://industrial.panasonic.com/ww/products/motors-compressors/fa-motors/ac-servo-motors/minas-a5-panaterm>

(Note 3): All the functions of Control Motion Integrator can be used free of charge for 60 days after the installation. For using the "EtherCAT communication setting" function continuously after the elapse of 60 days, the key unit should be installed.

### ■ Required files for EtherCAT communication

The setup information (ESI files) required for EtherCAT communication is included in the installation data of software "Control Motion Integrator".

(Note): ESI (EtherCAT Slave Information)

## 1.2 Restrictions

### 1.2.1 Supported Functions

FP7 MC Unit is designed in conformity with the specifications and standard of EtherCAT®, however, FP7 MC Unit supports the items listed in the following table only.

#### ■ Comparison with EtherCAT specifications

Item	EtherCAT specifications	Supported items by FP7 MC Unit
Transmission system	100BASE-TX	Same as on the left.
Baud rate	100 Mbps	Same as on the left.
Transmission distance	Max. 100 m between nodes	Same as on the left.
Transmission cable	STP cable, category 5/5e	Always use a cable of category 5e or higher.
Topology	Line, Daisy chain, Star, Tree	Daisy chain (without branch)
Connected slave (Note 1) (Note 2) (Note 3)	EtherCAT-compatible devices	Panasonic AC Servo Motor A6B/A5B series S-LINK V Gateway Controller SL-VGU1-EC series Communication Unit for Digital Sensor SC-GU3-03 series
No. of connected slaves (Note 4)	65535	AFP7MC16EC: 1 to 144 (Servo/Encoder: Max. 16, Others: 128) AFP7MC32EC: 1 to 160 (Servo/Encoder: Max. 32, Others: 128) AFP7MC64EC: 1 to 192 (Servo/Encoder: Max. 64, Others: 128)

(Note 1): The A6B series and SL-VGU1-EC series are available since the FP7 MC Unit Ver.1.2. The Communication Unit for Digital Sensor SC-GU3-03 series will be available in the near future.

(Note 2): More than one A6B or A5B should exist on a network. Also, the mixed connection of A6B and A5B is available.

(Note 3): Hubs for EtherCAT and Ethernet cannot be used.

(Note 4): As for Encoder, only the operation of the encoder input terminal GX-EC0211 made by Omron Corporation has been confirmed.

#### ■ Control mode

Control mode of EtherCAT	Supported function of A6B/A5B	Supported items by FP7 MC Unit
Cyclic position control mode (csp)	Supported	The cyclic position control mode (csp) is used when using it in combination with FP7 MC Unit.
Profile position control mode (pp)	Unsupported	Only the home return position control mode (Method33/34/37) is supported. The cyclic position control mode (csp) is used when using it in combination with FP7 MC Unit.
Home return position control mode (hm)	Supported	
Interpolation position control mode (ip)	Unsupported	When using it in combination with FP7 MC Unit, FP7 MC Unit performs the interpolation control.
Cyclic speed control mode (csv)	Supported	Unsupported
Profile speed control mode (pv)		
Cyclic torque control mode (cst)		
Profile torque control mode (tq)		

## 1.2.2 Restrictions by Power Consumption in FP7 System

The unit has the following internal current consumption. Make sure that the total current consumption is within the capacity of the power supply with consideration of all other units used in combination with this unit.

Name	Product no.	Consumption current
FP7 Motion Control Unit	AFP7MC16EC AFP7MC32EC AFP7MC64EC	180 mA or less

## 1.2.3 Applicable Versions of FPWIN GR7 and FP7 Units

For using FP7 MC Unit, the following versions of FPWIN GR7 and units are required.

Item	Applicable versions
Programming tool software Control FPWIN GR7	Ver.2.12 or later
FP7 CPU Unit	There is no restriction on the version.
	For using the EC packet monitor function of FP7 MC Unit, use FP7 CPU Unit (Ethernet function- built-in type).
	For using the time chart function of FP7 MC Unit, the following version of a CPU unit is required. CPS4*/CPS3*: Ver.4.40 or later, CPS2: Ver.1.40 or later

## 1.3 System Configuration

### 1.3.1 Example of System Configuration

The following figure shows the example of the configuration of one axis when using over limit switches and a near home switch.

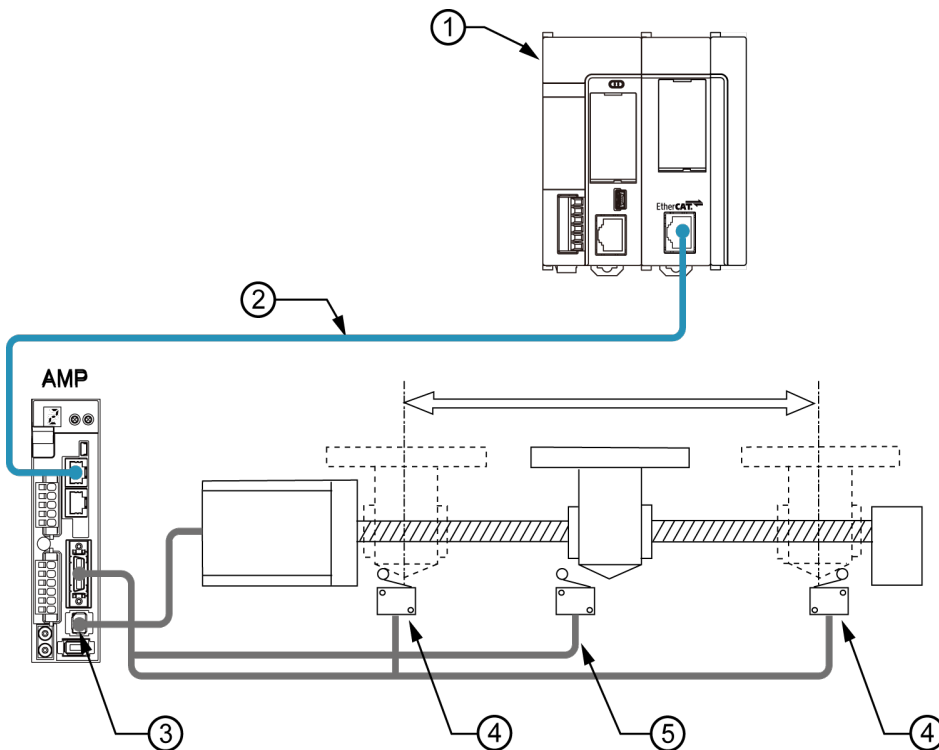

#### ■ Configuration of devices

No.	Item	Explanation
①	FP7	The above figure shows the minimum configuration that FP7 CPU Unit, FP7 MC Unit and an end unit are combined. For FP7 MC Unit, the units for 16 axes, 32 axes, and 64 axes are available.
②	Shielded twisted pair (STP) cable	FP7 MC Unit and Servo Amplifier A6B/A5B are connected with a shielded twisted pair (STP) cable.
③	Servo amplifier A6B/A5B	The units of the number of required axes are connected.
④	Over limit switch	The over limit switches are connected to the servo amplifier. When using the servo amplifier in combination with FP7 MC Unit, the over limit switches are connected to the terminals allocated to the general-purpose monitor inputs of the servo amplifier (SI-MON3/SI-MON4).
⑤	Near home switch	The near home switch is connected to the servo amplifier. It is connected to the terminal allocated to the near home input (HOME).



### 1.3.2 Type of Software

The following three software are used for using the system combining FP7 MC Unit and Servo Amplifier A6B/A5B.

#### ■ Control Motion Integrator

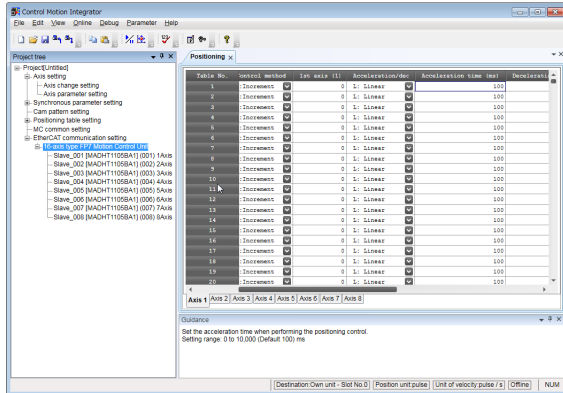

**Application:**

This software is used for setting parameters of FP7 MC Unit, monitoring the state and test operations.

- Setting of EtherCAT communication parameters
- Setting of Positioning Parameters
- Setting of positioning tables, etc.

**Download destination:**

FP7 MC Unit

**Connection with the Unit:**

Connect to the USB port of FP7 CPU Unit

#### ■ Control FPWIN GR7

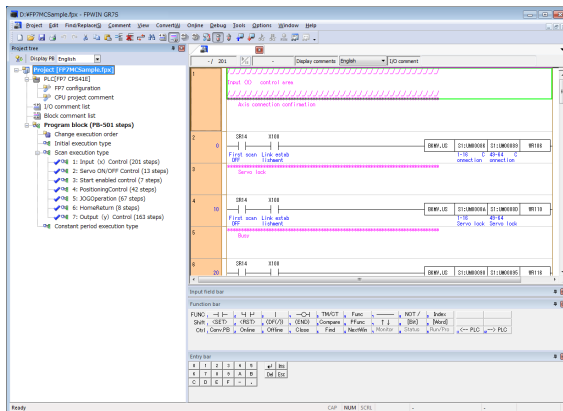

**Application:**

This software is used for configuring the whole FP7 system and creating user programs.

**Download destination:**

FP7 CPU Unit

**Connection with the Unit:**

Connect to the USB port of FP7 CPU Unit

#### ■ PANATERM

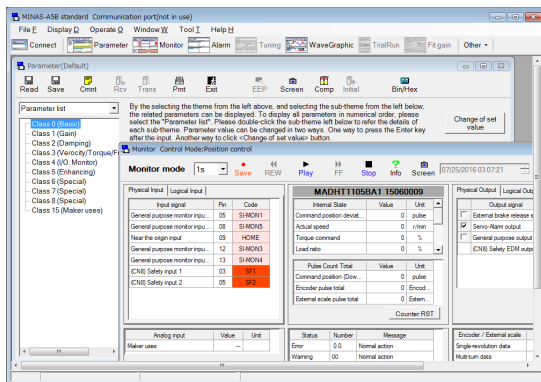

**Application:**

This software is used for setting parameters and monitoring the states of Servo Amplifier A6B/A5B series.

**Download destination:**

Servo amplifier A6B/A5B

**Connection with the Unit:**

Connect to the USB port of Servo Amplifier A6B/A5B.

## 1.4 Mechanism of Processing

### 1.4.1 Schematic View

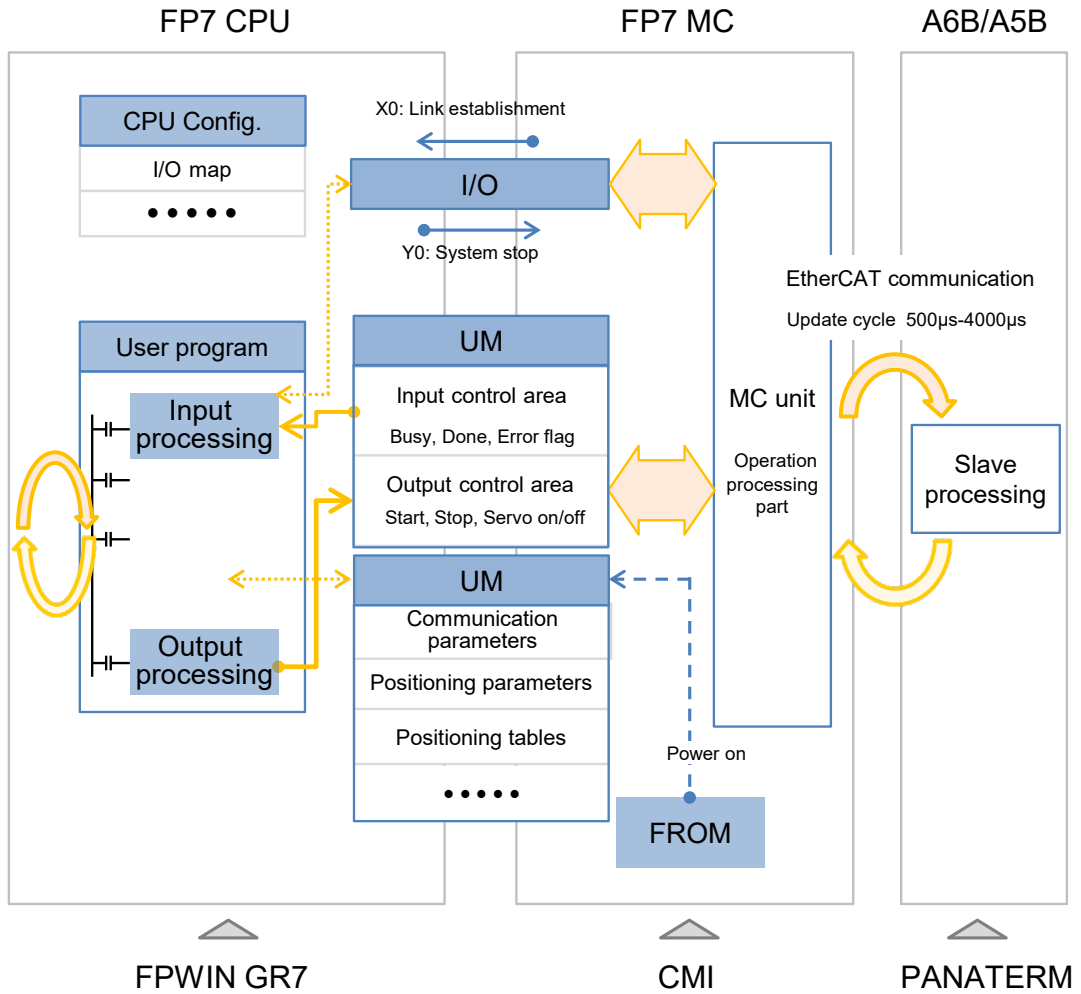

## 1.4.2 Operation When Power Supply Turns On

---

- FP7 MC Unit reads the "parameters for FP7 MC Unit" stored in the FROM (FlashROM) within the unit and sets them in the memory areas within the unit.
- FP7 MC Unit starts the communication with the slaves (servo amplifiers) connected to EtherCAT. Once the links with the slaves (servo amplifiers) are established, it is notified to FP7 CPU Unit by the input relay (X0).
- When the mode setting switch is set to RUN mode, FP7 CPU Unit checks that the state of the FP7 system is correct, switches the mode to RUN mode, and executes user programs.

## 1.4.3 Start/Stop by User Programs

---

- For FP7 MC Unit, main I/O signals to execute various controls (such as positioning, JOG operation, home return, and stop) are allocated to the unit memories (UM).
- In the unit memories (UM) "output control area", request signals to perform start and stop controls are allocated. In the unit memories "Input control area", flags such as busy flag and error flag to check the start conditions are allocated.
- FP7 MC Unit controls operations by reading or writing data from or to these unit memories.



# 2

## **Names and Functions of Parts**

## 2.1 Names and Functions of Parts

### 2.1.1 Names and Functions of Parts

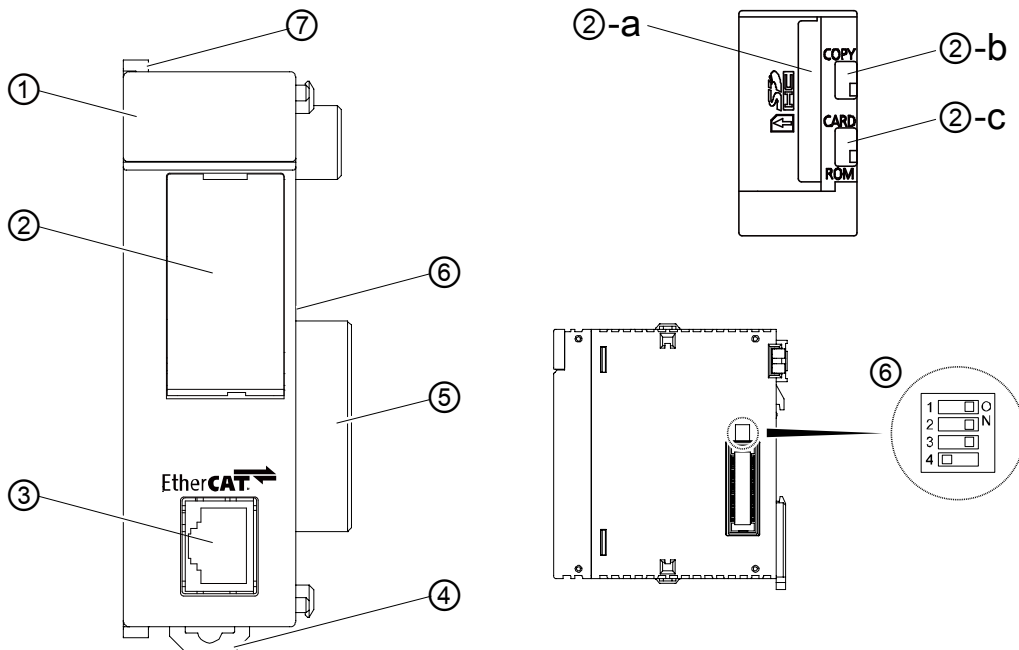

#### ■ Names and Functions of Parts

No.	Name	Function
①	Operation monitor LEDs	Indicates the state of EtherCAT communication, the occurrence states of unit's errors and alarms.
②	Card cover	An SD memory card slot is located under the cover.
a	Card slot	An SD memory card is inserted.
b	COPY switch	This is provided for expansion. Use the switch at the factory default (lower side) as it is.
c	Memory selector switch	This is provided for expansion. Use the switch at the factory default (lower side) as it is.
③	Network connector (RJ45)	This is the connector for connecting to EtherCAT.
④	DIN hook	This hook is used to install the unit on a DIN rail.
⑤	Unit connector	Connects the internal circuits between units.
⑥	Mode setting switch	This switch is used for the system. Use this at the factory default (nos.1-3: ON, no.4: OFF) as it is.
⑦	Fixing hook	This hook is used to fix units.

2.1.2 Operation Monitor LEDs



LED	Color	Status	Description
—	Blue	ON	Turns on when the power is supplied to the unit.
EC RUN	Green	OFF	INIT state
		Blinking	Pre-Operational state
		Single flash	Safe-Operational state
		ON	Operational state
EC ERR	Red	OFF	No error
		ON	EtherCAT communication error
EC L/A	Green	OFF	LINK is not established.
		Flickering	LINK is established. Data is sent/received.
		ON	LINK is established. Data is not sent/received.
[SD]	Green	ON	SD memory card is being accessed.
		OFF	Other than the above state.
CARD	Green	(Reserved for system)	
COPY	Green	(Reserved for system)	
ERR	Red	ON	Unit error occurs.
		Blinking	Unit warning occurs.
		OFF	Other than the above states.
ALM	Red	ON	Unit alarm occurs.
		OFF	Other than the above state.

(Note 1): Blinking and single flash of EC RUN are activated as below.

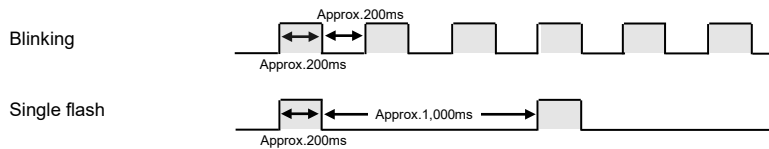

### 2.1.3 ESM (State Transition Diagram)

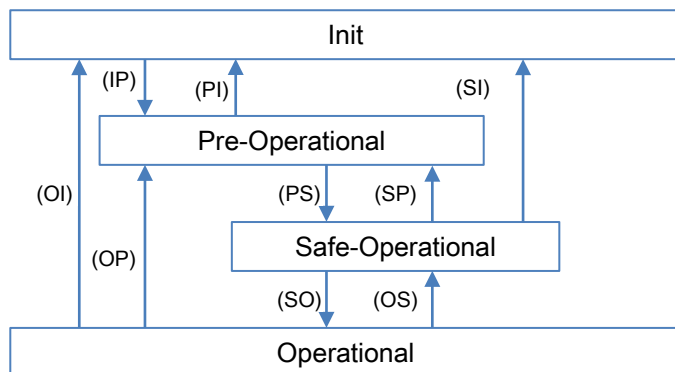

Reference: Created by us based on "Operating principle of EtherCAT" issued by ETG

ESM state (Abbr.)	SDO communication Send/Receive	PDO communication (S→M)	PDO communication (M→S)	Description
Init	Not available	Not available	Not available	The state that the communication part is being initialized and data cannot be sent/received using SDO (Mailbox) and PDO.
Pre-Operational (PreOP)	Available	Not available	Not available	The state that data can be sent/received using SDO (Mailbox).
Safe-Operational (SafeOP)	Available	Available	Not available	The state that data can be sent/received using SDO (Mailbox) and data can be sent (from slaves to master) using PDO.
Operational (OP)	Available	Available	Available	The state that data cannot be sent/received using SDO (Mailbox) and PDO.

(Note): S: Slave, M: Master

#### ■ What is ESM (EtherCAT State Machine)?

- ESM shows the state of the communication determined as the specifications of EtherCAT.
- The state transition is performed between FP7 MC Unit and Servo Amplifier A6B/A5B, any settings or programming by users are not required.

#### ■ Confirmation method

- The state of ESM can be confirmed by the operation monitor LED "EC RUN" on the front side of FP7 MC Unit.
- When communication is performed, "Operational (OP)" (EC RUN LED) is on, and the input relay "X0 (Link establishment)" of FP7 MC Unit is on.



# 3

## Installation and Wiring

## 3.1 Setting of Node Address (ID)

### 3.1.1 Type of Setting Method

When using FP7 MC Unit in combination with Servo Amplifier A6B/A5B, the following three methods are available for setting node addresses.

①	Set by the software CMI on FP7 MC Unit.
②	Set by the rotary switches on the front side of Servo Amplifier A6B/A5B.
③	Set in the ESC configuration area (SII area) of Servo Amplifier A6B/A5B. (For the details of the setting methods, refer to the manual of the servo amplifier.)

#### ■ Combination of setting methods

	Settings of Servo Amplifier A6B/A5B			Settings of FP7 MC Unit	
	Settings by Panaterm		Rotary switches	Settings by CMI	
	Pr7.40	Pr7.41		MC common settings dialog box Node address discrimination method	Device editor window general tab Node address discrimination method
①	0	0	00	Follow the setting value of Station Address.	-
②	0	0	Arbitrary ID	Follow the node address discrimination method of each slave.	Explicit Device ID
③	0	1	00		ESC register (0x0012)

### 3.1.2 Settings of Servo Amplifier MINAS A6B/A5B

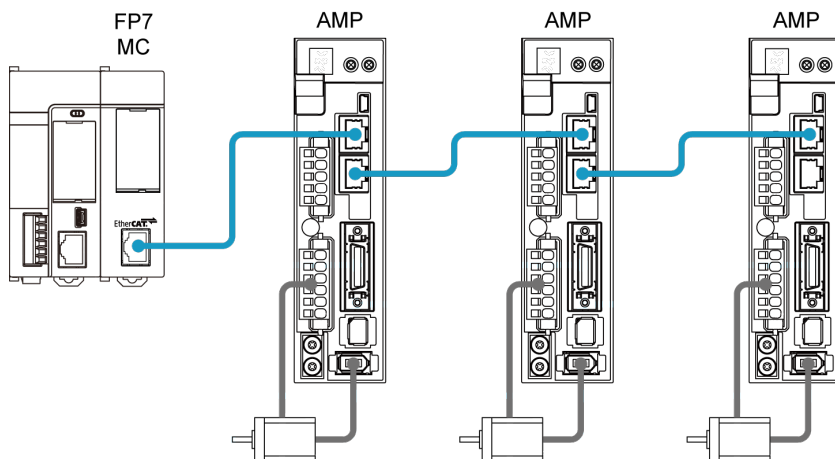

### ■ Parameter settings by Panaterm

The Station Alias (ID) is set by setting the parameters of Servo Amplifier [MINAS A6B/A5B].

Parameter		Parameter name	Function						
Classification	Number								
07	040	Station alias setting (upper)	<p>The high-order 8 bits of station alias are set.</p> <p>Station alias = <math>\underbrace{\text{Higher 8 bits}}_{\text{Setting of Pr7.40}} + \underbrace{\text{Lower 8 bits}}_{\text{Rotary switch setting}}</math></p> <p>However, Pr7.40 must be always set to "0". Because the maximum number of slaves for FP7 MC Unit is 192, the high-order 8 bits are "0".</p>						
07	041	Station alias selection	<p>The setting method of station alias is specified.</p> <table border="1"> <thead> <tr> <th>Setting</th> <th>Function</th> </tr> </thead> <tbody> <tr> <td>0</td> <td>The value set by the rotary switches on the front panel and Pr7.40 is used as the station alias.</td> </tr> <tr> <td>1</td> <td>The set value in the ESC configuration area (SII area) is used the station alias.</td> </tr> </tbody> </table>	Setting	Function	0	The value set by the rotary switches on the front panel and Pr7.40 is used as the station alias.	1	The set value in the ESC configuration area (SII area) is used the station alias.
Setting	Function								
0	The value set by the rotary switches on the front panel and Pr7.40 is used as the station alias.								
1	The set value in the ESC configuration area (SII area) is used the station alias.								

### ■ Rotary switch setting

When the set value for Pr7.41 is "0", it is set using the two rotary switches on the front panel of Servo Amplifier MINAS A6B/A5B. When using the software CMI, set it to "00".

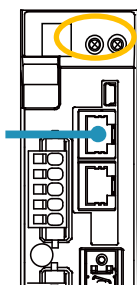

Setting value	Front panel display		Function
	MSD	LSD	
0	0	0	The settings on the FP7 MC Unit side that is the higher master are valid. Make the setting using the setting software CMI.
01 to C0 (1 to 192)	Other numbers		The node address (ID) set by the rotary switches is valid. It is set by combination of hexadecimal 2 digits. Example) When node address is "20", set MSD to 1 and LSD to 4.



### ◆ KEY POINTS

- Node addresses (IDs) can be set regardless of the connection order.
- When the same unit number is redundantly specified on the same network, an error occurs.

### 3.1.3 Setting by Software CMI

#### ■ EtherCAT communication node address discrimination method

MC common settings x		
Setting		
	Threshold of the number of times of PDO error judgement	3
	All nodes participation wait time (s)	60
	Operation when an error occurs	All axes stop
	Deceleration stop operation	Deceleration stop
MC operation	RUN->PROG. operation	Deceleration stop
	Error alarm to CPU unit	Yes
	Interpolation operation control_P point operation	Allow directional shift
	Extend monitor value	1 word
	Tool operation monitoring time (s)	10
EtherCAT communication	Node address discrimination method	Follow the setting value of StationAddress.
	EtherCAT communication cycle (us)	500
	Revision check	Disabled
Debug Function	EC packet monitor request flag setting	Disabled
	Execute EC Packet Monitor after Power ON	Not executed

Item	Name	Function						
EtherCAT communication	Node address discrimination method	Select a node address discrimination method.						
		<table border="1"> <thead> <tr> <th>Setting</th> <th>Function</th> </tr> </thead> <tbody> <tr> <td>Follow the setting value of Station Address.</td> <td>Set by the station address in the "General" tab in the EtherCAT communication setting by the software CMI.</td> </tr> <tr> <td>Follow the node address discrimination method of each slave.</td> <td>Set node addresses by the station alias setting of the servo amplifier.</td> </tr> </tbody> </table>	Setting	Function	Follow the setting value of Station Address.	Set by the station address in the "General" tab in the EtherCAT communication setting by the software CMI.	Follow the node address discrimination method of each slave.	Set node addresses by the station alias setting of the servo amplifier.
		Setting	Function					
Follow the setting value of Station Address.	Set by the station address in the "General" tab in the EtherCAT communication setting by the software CMI.							
Follow the node address discrimination method of each slave.	Set node addresses by the station alias setting of the servo amplifier.							

### ■ EtherCAT communication [Node address discrimination method: "Follow the setting value of Station Address"]

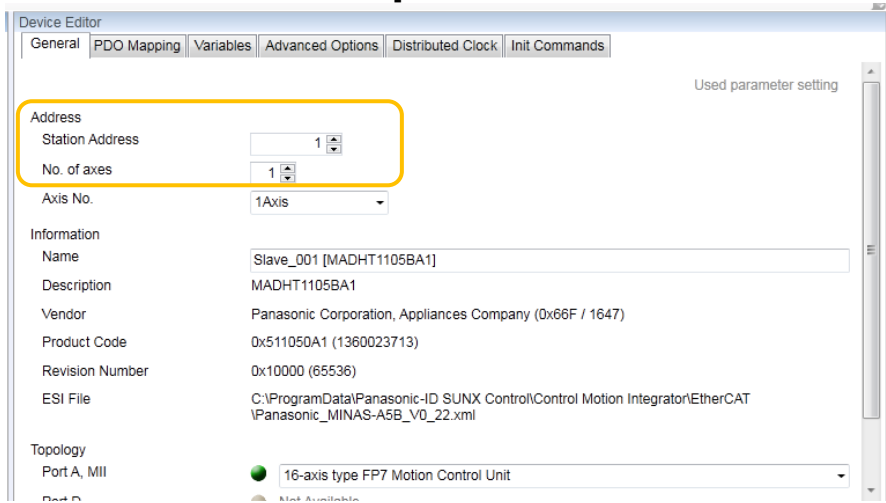

#### ◆ PROCEDURE

1. Double-click a slave registered in the EtherCAT communication setting in the project tree.  
The device editor opens.
2. Set node addresses (IDs) for each servo amplifier.
3. Press the [OK] button.



#### ◆ KEY POINTS

- Node addresses (IDs) can be set regardless of the connection order.
- When the rotary switches are all "00", they are allocated in the connection order.
- When the same unit number is redundantly specified on the same network, an error occurs.
- Set the address for the EtherCAT communication as a node address (ID).
- Set numbers specified in a user program for axis numbers.

■ EtherCAT communication [Node address discrimination method: "Follow the node address discrimination method of each slave"]

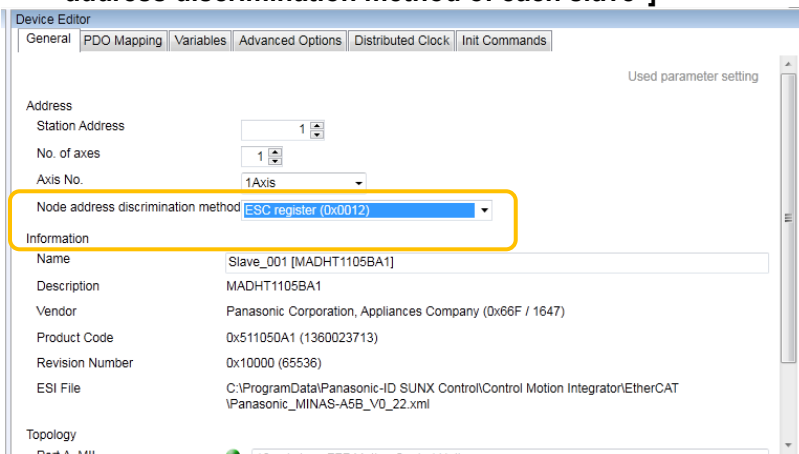

Name	Function						
Node address discrimination method	<p>The node address setting method follows the setting method of each slave device.</p> <table border="1" data-bbox="381 794 1205 1128"> <thead> <tr> <th data-bbox="381 794 584 832">Setting</th> <th data-bbox="584 794 1205 832">Function</th> </tr> </thead> <tbody> <tr> <td data-bbox="381 832 584 890">ESC register (0x0012)</td> <td data-bbox="584 832 1205 890">Set the set values in the SC configuration area (SII area) as node addresses.</td> </tr> <tr> <td data-bbox="381 890 584 1128">Explicit Device ID</td> <td data-bbox="584 890 1205 1128"> <p>Set the values set by the rotary switches on the front panel and Pr7.40 as node addresses.</p> <p style="text-align: center;">Station alias = <math>\underbrace{\hspace{2em}}_{\text{Higher 8 bits}} + \underbrace{\hspace{2em}}_{\text{Lower 8 bits}}</math></p> <p style="text-align: center;">Setting of Pr7.40      Rotary switch setting</p> <p>Because the maximum number of slaves for FP7 MC Unit is 192, Pr7.40 is "0".</p> </td> </tr> </tbody> </table>	Setting	Function	ESC register (0x0012)	Set the set values in the SC configuration area (SII area) as node addresses.	Explicit Device ID	<p>Set the values set by the rotary switches on the front panel and Pr7.40 as node addresses.</p> <p style="text-align: center;">Station alias = <math>\underbrace{\hspace{2em}}_{\text{Higher 8 bits}} + \underbrace{\hspace{2em}}_{\text{Lower 8 bits}}</math></p> <p style="text-align: center;">Setting of Pr7.40      Rotary switch setting</p> <p>Because the maximum number of slaves for FP7 MC Unit is 192, Pr7.40 is "0".</p>
Setting	Function						
ESC register (0x0012)	Set the set values in the SC configuration area (SII area) as node addresses.						
Explicit Device ID	<p>Set the values set by the rotary switches on the front panel and Pr7.40 as node addresses.</p> <p style="text-align: center;">Station alias = <math>\underbrace{\hspace{2em}}_{\text{Higher 8 bits}} + \underbrace{\hspace{2em}}_{\text{Lower 8 bits}}</math></p> <p style="text-align: center;">Setting of Pr7.40      Rotary switch setting</p> <p>Because the maximum number of slaves for FP7 MC Unit is 192, Pr7.40 is "0".</p>						



◆ KEY POINTS

- If the slave connection order specified in CMI differs from the slave connection order in the network, error "0x00F0\_2061H" (network configurations verify error) will occur.

### 3.1.4 Node Address Setting and State Confirmation

The confirmation areas of the ENI file registration by the node address setting and node addresses on the network are as follows.

Node no.	Unit memory no. (Hex)	Name	Default	Setting range and description																																		
Node 1-16	UM 000FE	Registered slave table	H0	The bits corresponding to the station addresses registered in the ENI file turn on. <table border="1"> <thead> <tr> <th>bit</th> <th>Node no.</th> </tr> </thead> <tbody> <tr><td>0</td><td>Node 1+16n</td></tr> <tr><td>1</td><td>Node 2+16n</td></tr> <tr><td>2</td><td>Node 3+16n</td></tr> <tr><td>3</td><td>Node 4+16n</td></tr> <tr><td>4</td><td>Node 5+16n</td></tr> <tr><td>5</td><td>Node 6+16n</td></tr> <tr><td>6</td><td>Node 7+16n</td></tr> <tr><td>7</td><td>Node 8+16n</td></tr> <tr><td>8</td><td>Node 9+16n</td></tr> <tr><td>9</td><td>Node 10+16n</td></tr> <tr><td>10</td><td>Node 11+16n</td></tr> <tr><td>11</td><td>Node 12+16n</td></tr> <tr><td>12</td><td>Node 13+16n</td></tr> <tr><td>13</td><td>Node 14+16n</td></tr> <tr><td>14</td><td>Node 15+16n</td></tr> <tr><td>15</td><td>Node 16+16n</td></tr> </tbody> </table>	bit	Node no.	0	Node 1+16n	1	Node 2+16n	2	Node 3+16n	3	Node 4+16n	4	Node 5+16n	5	Node 6+16n	6	Node 7+16n	7	Node 8+16n	8	Node 9+16n	9	Node 10+16n	10	Node 11+16n	11	Node 12+16n	12	Node 13+16n	13	Node 14+16n	14	Node 15+16n	15	Node 16+16n
bit	Node no.																																					
0	Node 1+16n																																					
1	Node 2+16n																																					
2	Node 3+16n																																					
3	Node 4+16n																																					
4	Node 5+16n																																					
5	Node 6+16n																																					
6	Node 7+16n																																					
7	Node 8+16n																																					
8	Node 9+16n																																					
9	Node 10+16n																																					
10	Node 11+16n																																					
11	Node 12+16n																																					
12	Node 13+16n																																					
13	Node 14+16n																																					
14	Node 15+16n																																					
15	Node 16+16n																																					
Node 17-32	UM 000FF																																					
Node 33-48	UM 00100																																					
Node 49-64	UM 00101																																					
Node 65-80	UM 00102																																					
Node 81-96	UM 00103																																					
Node 97-112	UM 00104																																					
Node 113-128	UM 00105																																					
Node 129-144	UM 00106																																					
Node 145-160	UM 00107																																					
Node 161-176	UM 00108																																					
Node 177-192	UM 00109																																					

(Note 1): Sixteen node numbers are allocated to each area (1 word).

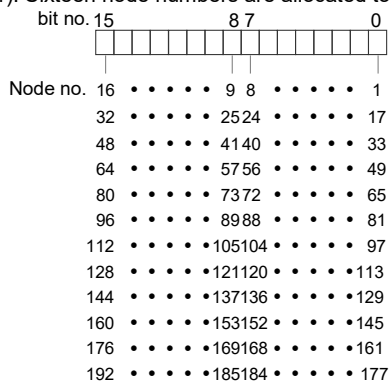

Node no.	Unit memory no. (Hex)	Name	Default	Setting range and description																																		
Node 1-16	UM 0010A	Network participating slave table	H0	The bits corresponding to the station addresses of slaves participating in the network turn on. <table border="1" style="margin-left: 20px;"> <thead> <tr> <th>bit</th> <th>Node no.</th> </tr> </thead> <tbody> <tr><td>0</td><td>Node 1+16n</td></tr> <tr><td>1</td><td>Node 2+16n</td></tr> <tr><td>2</td><td>Node 3+16n</td></tr> <tr><td>3</td><td>Node 4+16n</td></tr> <tr><td>4</td><td>Node 5+16n</td></tr> <tr><td>5</td><td>Node 6+16n</td></tr> <tr><td>6</td><td>Node 7+16n</td></tr> <tr><td>7</td><td>Node 8+16n</td></tr> <tr><td>8</td><td>Node 9+16n</td></tr> <tr><td>9</td><td>Node 10+16n</td></tr> <tr><td>10</td><td>Node 11+16n</td></tr> <tr><td>11</td><td>Node 12+16n</td></tr> <tr><td>12</td><td>Node 13+16n</td></tr> <tr><td>13</td><td>Node 14+16n</td></tr> <tr><td>14</td><td>Node 15+16n</td></tr> <tr><td>15</td><td>Node 16+16n</td></tr> </tbody> </table>	bit	Node no.	0	Node 1+16n	1	Node 2+16n	2	Node 3+16n	3	Node 4+16n	4	Node 5+16n	5	Node 6+16n	6	Node 7+16n	7	Node 8+16n	8	Node 9+16n	9	Node 10+16n	10	Node 11+16n	11	Node 12+16n	12	Node 13+16n	13	Node 14+16n	14	Node 15+16n	15	Node 16+16n
bit	Node no.																																					
0	Node 1+16n																																					
1	Node 2+16n																																					
2	Node 3+16n																																					
3	Node 4+16n																																					
4	Node 5+16n																																					
5	Node 6+16n																																					
6	Node 7+16n																																					
7	Node 8+16n																																					
8	Node 9+16n																																					
9	Node 10+16n																																					
10	Node 11+16n																																					
11	Node 12+16n																																					
12	Node 13+16n																																					
13	Node 14+16n																																					
14	Node 15+16n																																					
15	Node 16+16n																																					
Node 17-32	UM 0010B																																					
Node 33-48	UM 0010C																																					
Node 49-64	UM 0010D																																					
Node 65-80	UM 0010E																																					
Node 81-96	UM 0010F																																					
Node 97-112	UM 00110																																					
Node 113-128	UM 00111																																					
Node 129-144	UM 00112																																					
Node 145-160	UM 00113																																					
Node 161-176	UM 00114																																					
Node 177-192	UM 00115																																					

(Note 1): Sixteen node numbers are allocated to each area (1 word).

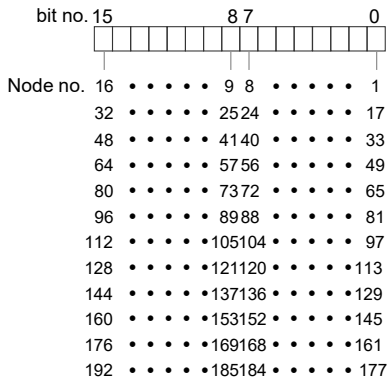







## 3.2 Connection of Network

### 3.2.1 Wiring

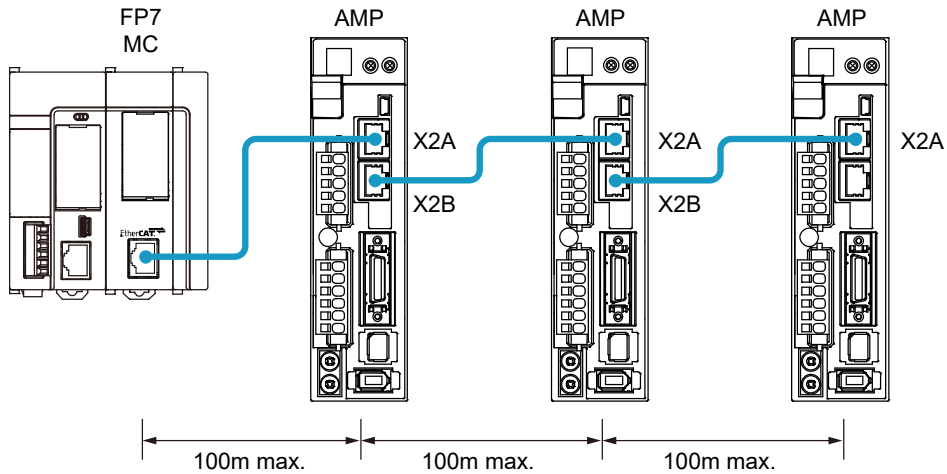

- The cable connected to FP7 MC Unit is connected to the connector X2A of Servo Amplifier A6B/A5B.
- The distance between each node should be within 100m.

### 3.2.2 Precautions on Wiring

- Always use shielded twisted pair (STP) cables that are compatible with category 5e or higher.
- Turn off the power supplies for the system before wiring cables.
- To prevent the cable from coming off, securely connect the connector of the cable to the network connector (RJ45 connector) of the unit.
- Hubs for EtherCAT and Ethernet cannot be used.

### ■ Conformity conditions to EMC Directive

Although this product conforms to EN61131-2 for the European EMC Directive (EMC Directive 2004/108/EC), the following wiring condition is required.

- Always use shielded twisted pair (STP) cables that are compatible with category 5e or higher.
- Attach ferrite cores at two points on the FP7 MC Unit side and Servo Amplifier A6B/A5B side, and wire the cable to make a loop. Recommended ferrite core: Takeuchi Industry Co., Ltd. SFT-72SN or equivalent.

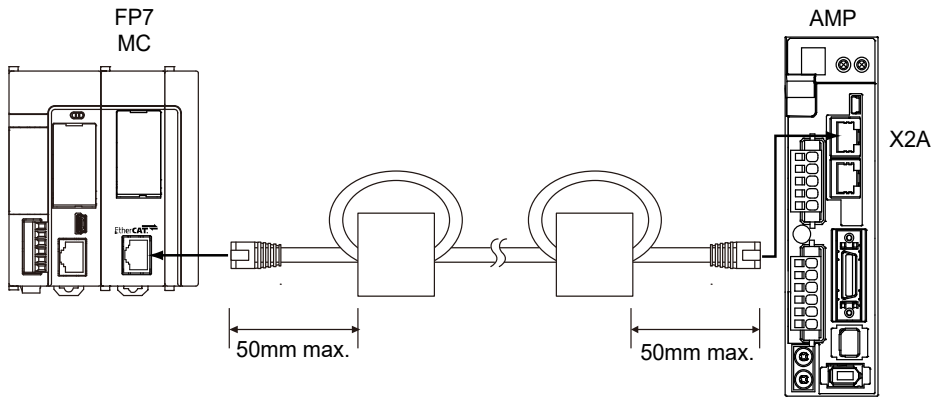

## 3.3 Connection of Servo Amplifier

### 3.3.1 Connection of Input Signals

For the system which uses the over limit switches and near home switch, connect them to the I/O connector of Servo Amplifier A6B/A5B.

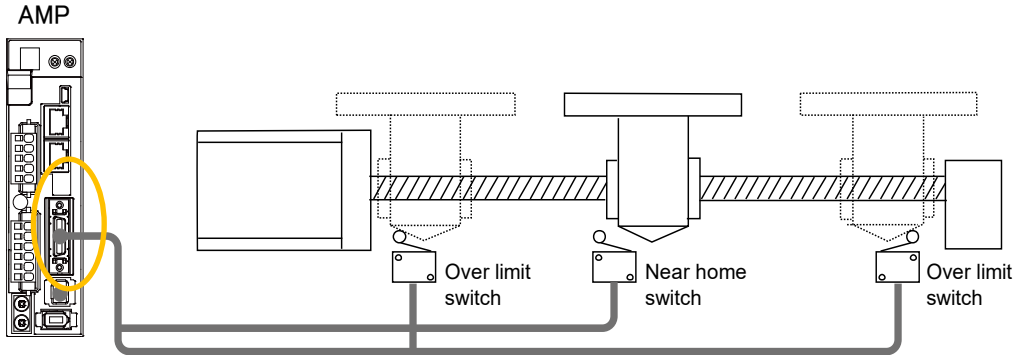

#### ■ I/O connector (X4): Allocation of functions at the factory setting

X4 connector		Function at the factory setting			Application on the FP7 MC Unit side
Name	Pin no.	Signal name	Code	Logic	
SI1	5	General-purpose monitor input 5	SI-MON5	A contact	It can be only monitored by the unit memories.
SI2	7	CW over-travel inhibit input	POT	B contact	
SI3	8	CCW over-travel inhibit input	NOT	B contact	Do not allocate POT or NOT.
SI4	9	Near home input	HOME	A contact	
SI5	10	External latch input 1	EXT1	A contact	It can be only monitored by the unit memories.
SI6	11	External latch input 2	EXT2	A contact	
SI7	12	General-purpose monitor input 3	SI-MON3	A contact	It is used as a limit +.
SI8	13	General-purpose monitor input 4	SI-MON4	A contact	It is used as a limit -.

(Note 1): The above table shows the allocation before shipment. It varies according to the setting of PANATERM.



#### ◆ KEY POINTS

- When using FP7 MC Unit in combination with Servo Amplifier A6B/A5B, the general-purpose inputs (SI-MON3 and SI-MON4) are used as limit inputs. For using the general-purpose monitor inputs (SI-MON3 and SI-MON4) as limit inputs, the setting of the limit switch should be set to "A: Enabled" in the "Axis parameter setting" menu of CMI.
- The over-travel inhibit inputs (POT, NOT) cannot be used as the limit inputs on the FP7 MC Unit side. Do not allocate the over-travel inhibit inputs (POT, NOT) to the I/O connector (X4) of Servo Amplifier A6B/A5B.



◆ **REFERENCE**

---

---

- For details of parameter settings, refer to "4.5 Connection of Limit and Near Home Switches".

# 4

## Basic Procedure

## 4.1 Section Details

The following are the procedures of configuring basic settings by connecting FP7 MC Unit and Servo Amplifier A6B/A5B. Confirm them before setting parameters and creating programs.

### ■ Operation procedure

	Item	Used tool	Outline of operation
①	Registration in I/O map of the unit	FPWIN GR7	Register the unit configuration of the FP7 system in the "I/O map" dialog box.
			Download the "I/O map" information to FP7 CPU Unit.
②	Allocation of used axes	CMI	Register the "configuration of axes" controlled by FP7 MC Unit in the "Used axis" setting dialog box.
③	Registration of network configuration	-	Set the rotary switches on Servo Amplifier A6B/A5B. It is recommended to set "00".
		CMI	Start "EtherCAT Configurator" and register slaves in accordance with the configuration to be used.
			Set station addresses and axis numbers.
			Download the "slave registration" information to FP7 MC Unit.
			Turn on and off the powers of Servo Amplifier A6B/A5B and FP7, and then turn them on again.
Confirm the communication state by LEDs or the monitor of CMI.			
④	Confirmation of the connections of limit and near home switches (Option)	-	Connect the limit and near home input switches to Servo Amplifier A6B/A5B.
		PANATERM	Set the input logic. Monitor the input state.
		CMI	Enable the functions on the FP7 MC Unit side. Set the input logic.
			Download the set information to FP7 MC Unit.
⑤	Storage of files	FPWIN GR7 CMI PANATERM	Save created files.



## 4.2 Registration in I/O Map

### 4.2.1 Creation of I/O Map

Before setting parameters or creating programs, register units to be used in the I/O map. The I/O map is created on FPWIN GR7. The following procedure is explained on the condition that FPWIN GR7 has already started.



#### ◆ PROCEDURE

1. Select "Options" > "FP7 Configuration" > "I/O map" in the menu bar.

The "I/O map" dialog box is displayed.

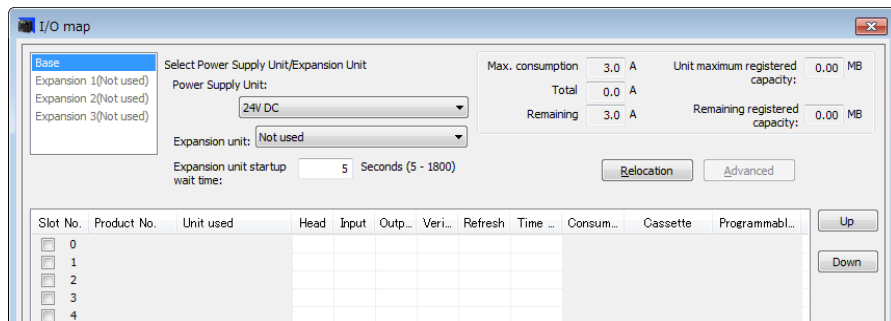

2. Double-click a desired slot.

The unit selection dialog box is displayed.

3. Select "Motion control" for "Unit type" and select the unit name used, and press the "OK" button.

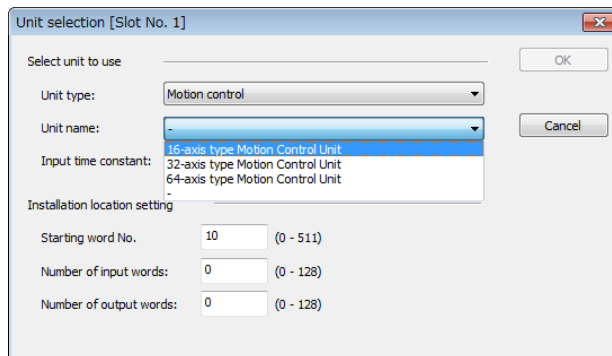

The selected unit is registered in the I/O map.

Slot No.	Product No.	Unit used	Head	Input	Outp...	Veri...	Refresh	Time ...	Consum...	Cassette	Programmabl...
<input type="checkbox"/>	0	AFP7CPS41E	FP7 CPU unit	0	10	10	Valid	Valid	200mA	Not registered	Not registered
<input checked="" type="checkbox"/>	1	AFP7MC16EC	16-axis type Motion .	10	1	1	Valid	Valid	160mA		
<input type="checkbox"/>	2										

4. Confirm the I/O map, and press the "OK" button.

The unit selection dialog box is displayed.

## 4.2.2 Download of I/O Map

---

The created I/O map is downloaded to the CPU unit as part of configuration information. Perform the following operations on FPWIN GR7.

### ■ Download to the CPU unit

The I/O map is saved in the CPU unit together with program data. Execute "Online" > "Download to PLC (Entire Project)".

## 4.2.3 Storage of I/O map

---

The created I/O map is saved as project data as part of configuration information. Perform the following operations on FPWIN GR7.

### ■ Save as files

- To save the I/O map as "Entire project", execute "Project" > "Save As".
- To save only the "I/O map setting" information, press the "Save Setting" button in the "I/O map" setting dialog box.

## 4.2.4 Confirmation of I/O Allocation

---

- I/O numbers allocated to the unit are decided by registering them in the I/O map.
- I/O numbers vary depending on the starting word number registered for the slot where the unit is installed.

Example) When the starting word number is 10, the "link establishment flag" of FP7 MC Unit is X100, and "system stop request signal" is Y100.



### ◆ REFERENCE

---

---

- For details, refer to "16.2 I/O Allocation".

### 4.2.5 Confirmation of Slot Numbers

Slot numbers are decided by registering units in the I/O map. Slot numbers are used when reading or writing the values of unit memories by user programs. They are also used when performing the data monitoring on FPWIN GR7.

#### ■ Slot number

Slot numbers are decided by each installation position of units. They are counted from the unit closest to the CPU unit.

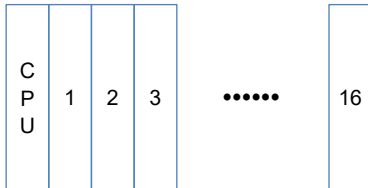

#### ■ Display on the I/O map of FPWIN GR7

Slot numbers are specified in the "I/O map" dialog box of FPWIN GR7.

Slot No.	Product No.	Unit used	Head	Input	Outp...	Veri...	Refresh	Time ...	Consum...	Cassette	Programmabl...
<input type="checkbox"/> 0	AFP7CPS41E	FP7 CPU unit	0	10	10	Valid	Valid		200mA	Not registered	Not registered
<input checked="" type="checkbox"/> 1	AFP7MC16EC	16-axis type Motion .	10	1	1	Valid	Valid		180mA		
<input type="checkbox"/> 2											

#### ■ Using by user programs

The following shows the case that reads values of unit memories using a user program. A slot number is specified at the beginning of a target operand.

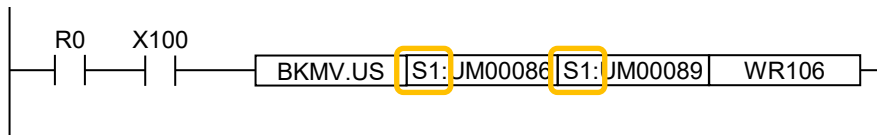

## 4.3 Setting of Used Axes

---

### 4.3.1 Registration of Used Axes

---

Axes to be used in FP7 MC Unit are allocated by CMI. The following procedure is explained on the condition that FP7 MC Unit has been already allocated in the I/O map.



#### ◆ PROCEDURE

---

1. Select "Tools" > "Control Motion Integrator" from the menu bar of FPWIN GR7.

The "Select Slot no." dialog box is displayed.

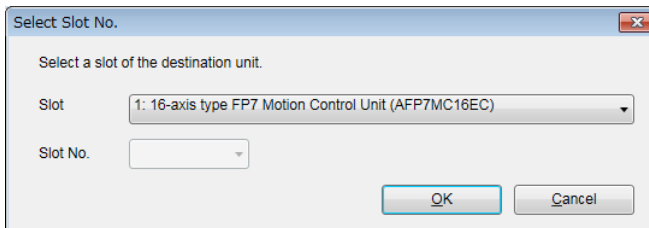

2. Select the slot number and unit of the FP7 MC Unit that the setting is made, and press the [OK] button.

"CMI" is activated, and the start dialog box is displayed.

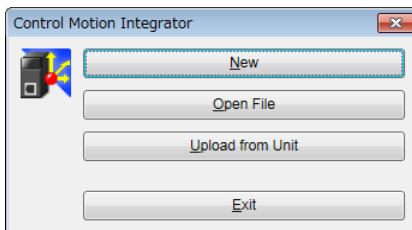

### 3. Press the [New] button.

The "Axis settings" dialog box is displayed.

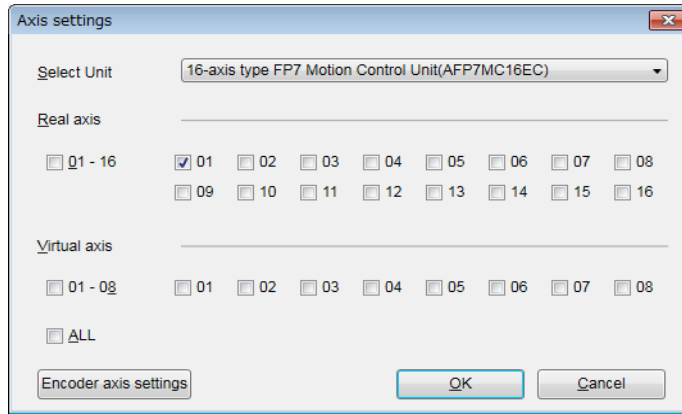

(This is the 16-axis type. For the 32-axis and 64-axis types, see p.4-9.)

Product no.	Number of usable axes	
	Real axis	Virtual axis
AFP7MC16EC	Max. 16 axes	Max. 8 axes
AFP7MC32EC	Max. 32 axes	Max. 16 axes
AFP7MC64EC	Max. 64 axes	Max. 32 axes

### 4. Select the axes to be used, and press the [OK] button.

The dialog box for the interpolation operation group setting is displayed. When you do not set the interpolation operation, go to step 6.

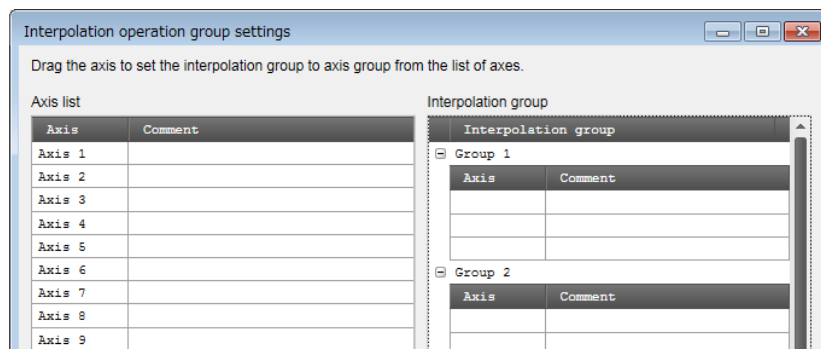

**5. Drag the line to be allocated for interpolation to the interpolation group field.**

The following picture shows the allocations of "axes 1 and 2" to "group 1" and "axes 3 and 4" to "group 2" of interpolation groups. When removing the axes from the interpolation groups, right-click on the target axis in the "Interpolation group" field and execute "Clear".

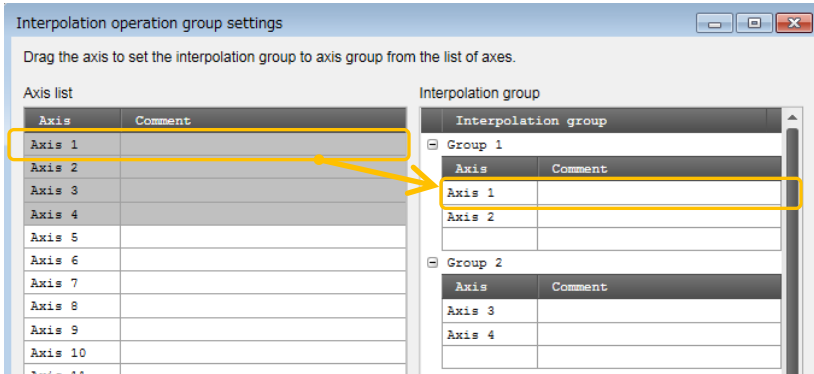

**6. Press the [OK] button.**

A confirmation message is displayed.

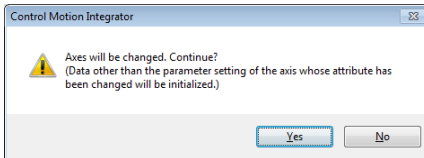

**7. Confirm the change and press the [Yes] button.**

The data table is created in accordance with the setting content. The corresponding axis numbers are also displayed in the project tree.

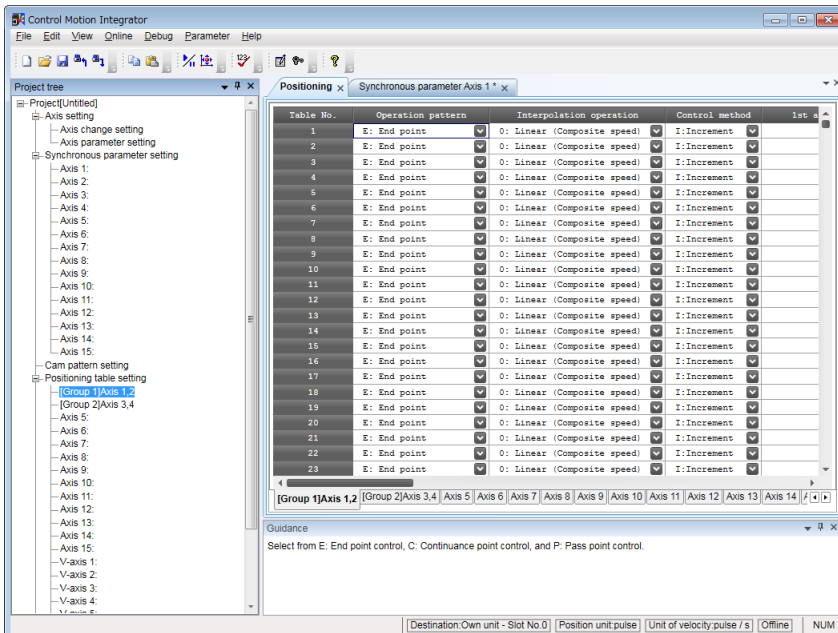



## ◆ KEY POINTS

- When setting interpolation groups, setting items of the movement amount and interpolation operation are added to the data table, and the group numbers are displayed.
- Closing the window with the X mark during editing displays a confirmation message. Press the [Yes] button to cancel and finish the operation.

### ■ Axis settings dialog box (For MC32EC)

Axis settings

Select Unit: 32-axis type FP7 Motion Control Unit (AFP7MC32EC)

Real axis

01 - 16  01  02  03  04  05  06  07  08  
 09  10  11  12  13  14  15  16  
 17 - 32  17  18  19  20  21  22  23  24  
 25  26  27  28  29  30  31  32

Virtual axis

01 - 16  01  02  03  04  05  06  07  08  
 09  10  11  12  13  14  15  16

ALL

Encoder axis settings OK Cancel

### ■ Axis settings dialog box (For MC64EC)

Axis settings

Select Unit: 64-axis type FP7 Motion Control Unit (AFP7MC64EC)

Real axis

01 - 16  01  02  03  04  05  06  07  08  
 09  10  11  12  13  14  15  16  
 17 - 32  17  18  19  20  21  22  23  24  
 25  26  27  28  29  30  31  32  
 33 - 48  33  34  35  36  37  38  39  40  
 41  42  43  44  45  46  47  48  
 49 - 64  49  50  51  52  53  54  55  56  
 57  58  59  60  61  62  63  64

Virtual axis

01 - 16  01  02  03  04  05  06  07  08  
 09  10  11  12  13  14  15  16  
 17 - 32  17  18  19  20  21  22  23  24  
 25  26  27  28  29  30  31  32

ALL

Encoder axis settings OK Cancel

## 4.4 Setting of Network Configuration

### 4.4.1 Registration of Slaves (Offline)

Slaves connected to FP7 MC Unit are registered using the EtherCAT communication setting menu "EtherCAT Configurator" of CMI. The following procedure is explained on the condition that CMI has already started.



#### ◆ PROCEDURE

1. Select "Parameter" > "EtherCAT communication settings" from the menu bar.

The "EtherCAT Configurator" window is displayed.

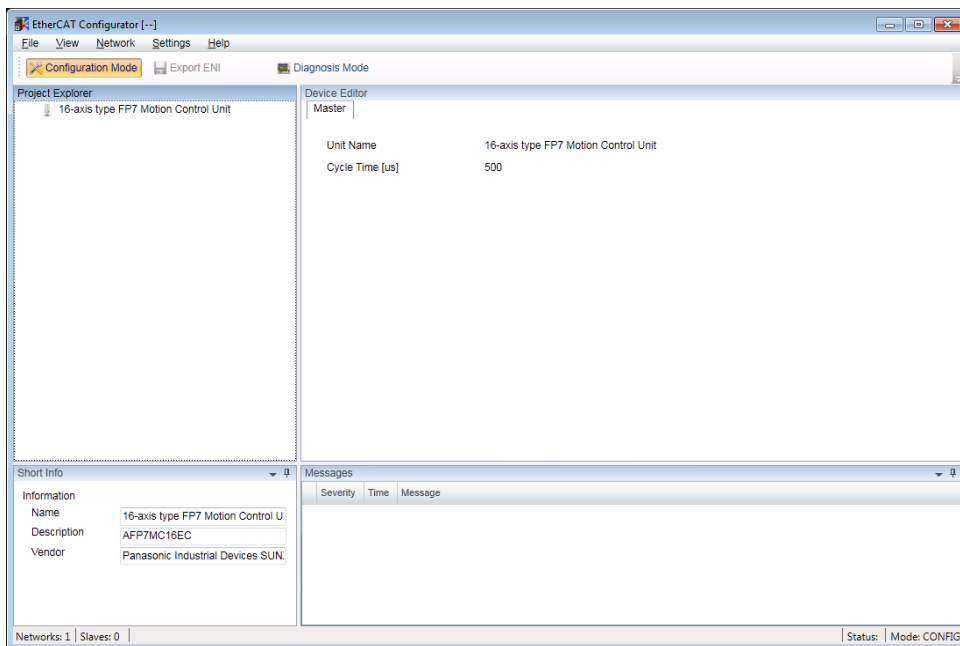

2. Right-click on "FP7 Motion Control Unit" in the project explorer.

The context menu is displayed.

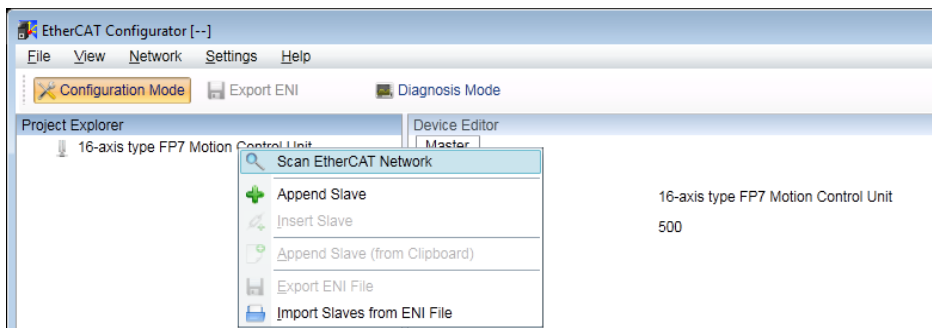



### 3. Select “Append Slave” from the context menu.

The dialog box for selecting slaves is displayed.

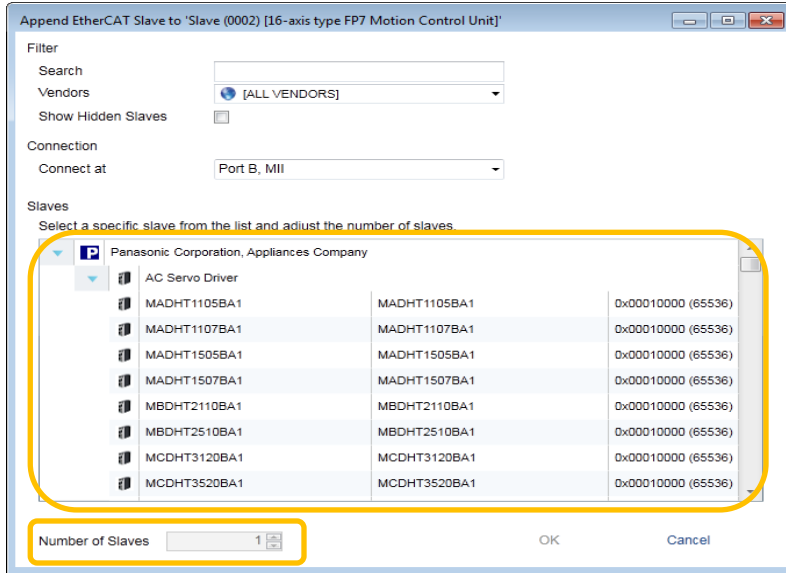

### 4. Select slaves (servo amplifier form) to be used from the list.

### 5. Input the number of slaves, and press the [OK] button.

The registration state of the slaves (A6B/A5B) connected to FP7 MC Unit is displayed in the project explorer. The list shows the slaves in the connection order from the unit connected to FP7 MC Unit first.

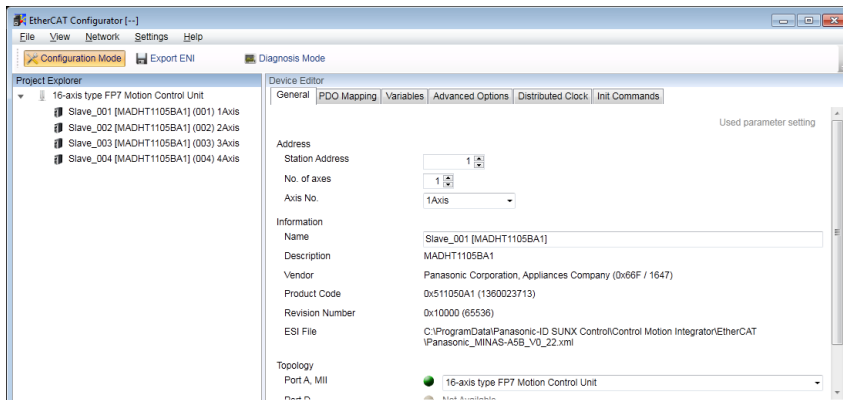

### 6. When there are multiple types of slaves (servo amplifier form), repeat steps 2 to 5.

## 4.4.2 Registration of Slaves (Online)

In FP7 MC Unit, the configuration of slaves connected to the network can be read and registered in online mode. The following procedure is explained on the condition that CMI has already started.



### ◆ PROCEDURE

1. Turn on the power supplies of all servo amplifiers A6B/A5B connected to the network.
2. Turn on the power of the FP7 MC system.

The "EC L/A" LED of FP7 MC Unit turns on or blinks after the execution of EtherCAT communication between FP7 MC Unit and Servo Amplifiers A6B/A5B.

3. Select "Parameter" > "EtherCAT communication settings" from the menu bar.

The "EtherCAT Configurator" window is displayed.

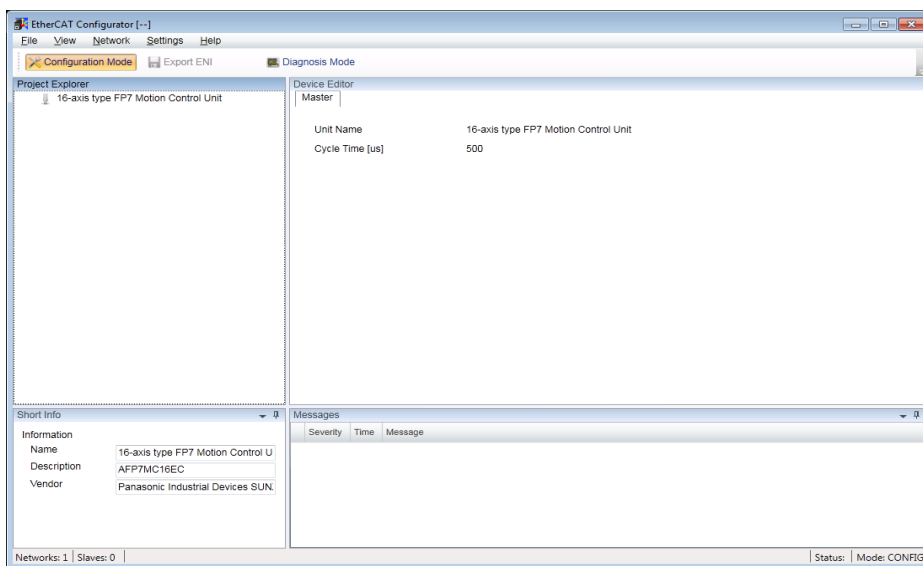

4. Right-click on "FP7 Motion Control Unit" in the project explorer.

The context menu is displayed.

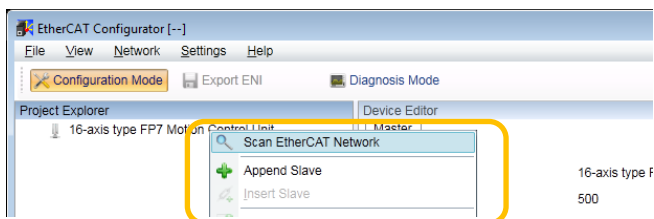

5. Select "Scan EtherCAT Network" from the context menu.

FP7 MC Unit executes scanning the network. The information on Servo Amplifiers A6B/A5B connected to FP7 MC Unit is displayed in the project explorer in the connection order.

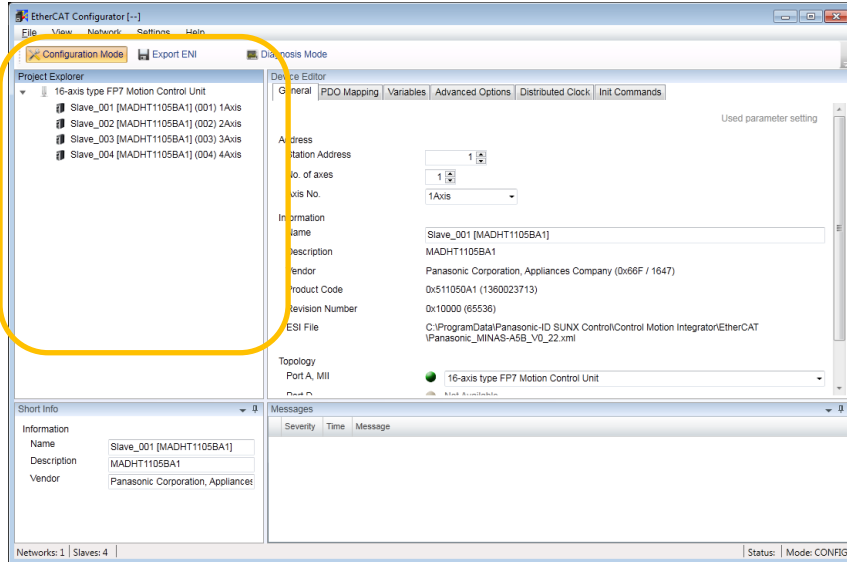

◆ KEY POINTS

- It takes approximately 10 seconds for one axis to complete the scanning of EtherCAT network.
- "Scan EtherCAT network" can be executed when the "EC L/A" LED on FP7 MC Unit is lit or blinking. Possible situations are as follows.

■ Unit state and network scanning operation

LEDs of FP7 MC Unit			Possible case and confirmation method	Network scanning
EC L/A	EC RUN	ERR		
ON	OFF	ON	"Network configurations verify error" occurs. In this case, even when the ERR LED is lit, the network scanning can be executed.  This error also occurs when using FP7 MC Unit for the first time as the information on the network configuration is not downloaded to FP7 MC Unit.	Executable
Flickering	ON	ON	"Network configurations verify error" may occur as the rotary switches on Servo Amplifier A6B/A5B are not set to "00". Set the rotary switches to "00" and restart the power supply.	Not executable
ON or Flickering	ON	OFF	The situation that the network configuration information has been downloaded and the number of connected servo amplifiers matches is possible. The network scanning can be executed.	Executable

### 4.4.3 Setting of Station Addresses and Axis Numbers

Once the information on devices connected to the network is displayed in the project explorer of EtherCAT Configurator, set the station addresses and axis numbers of Servo Amplifiers A6B/A5B.

#### ■ Explanation of terms

Name	Setting range	Description
Station address	1-192	ID of a slave used on the EtherCAT network. In the technical data of Servo Amplifier A6B/A5B, it is expressed as station alias (node ID).
No. of axes	Depends on slave devices.	The number of corresponding axes for slave devices is set.
Axis number	1-16 1-32 1-64	It is linked with various functions set for each axis in CMI such as axis parameter setting, positioning table setting, and synchronous parameter setting.
		The start requests and flags used in user programs are determined based on the "axis numbers" set in CMI. User programs are created using FPWIN GR7.

#### ■ Procedure

The following procedure is explained on the condition that slaves have already been registered in CMI.



#### ◆ PROCEDURE

1. Select an arbitrary slave (servo amplifier) in the project explorer.

The slave information is displayed on the "General" tab in the "Device Editor" window.

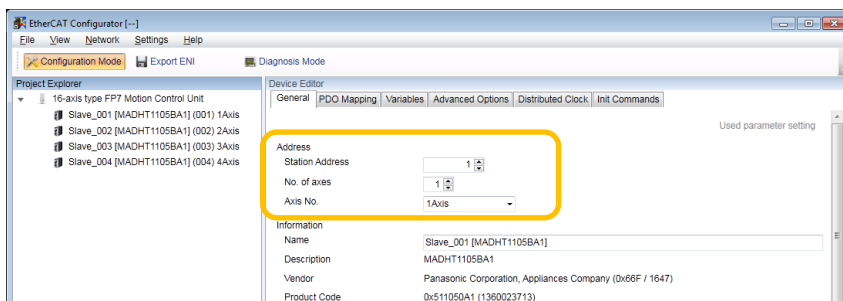

2. Input "Station Address" and "Axis No.".

**◆ KEY POINTS**

- **When a station address is overlapped, an error message is displayed on EtherCAT Configurator of CMI.**

Messages			
Severity	Time	Message	
ERR	14:00:27	Slave 'Slave_001 [MADHT1105BA1]' and slave 'Slave_002 [MADHT1105BA1]' use the same physical address.	
ERR	14:00:27	Slave 'Slave_001 [MADHT1105BA1]' and slave 'Slave_002 [MADHT1105BA1]' use the same physical address.	

- **When "Not use" is displayed in the project explorer, no "Axis no." is set. When slave devices are servo amplifiers or encoders, set axis numbers. If the information on the configuration of slaves (servo amplifiers, encoders) existing on the network without axis numbers is downloaded, an error occurs.**
- **When the number of axes specified in the used axis setting is more than the number of slave axes registered in the project explorer, the download is executed; however, "network configuration error" occurs when the power supplies of servo amplifiers and FP7 MC Unit turn off and on.**

■ **Setting example**

Although station addresses and axis numbers can be set arbitrarily, it is recommended to set the same numbers to facilitate the management. By default, station addresses are allocated in the connection order.

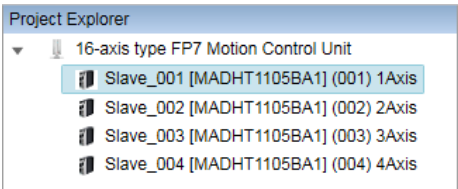
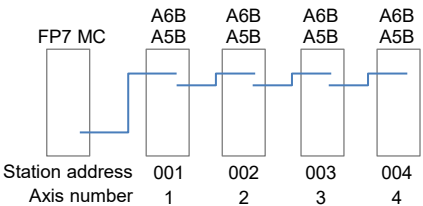
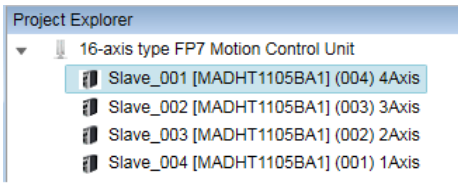
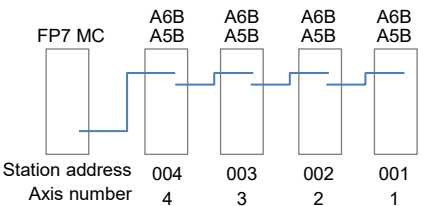
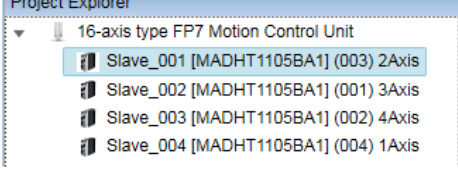
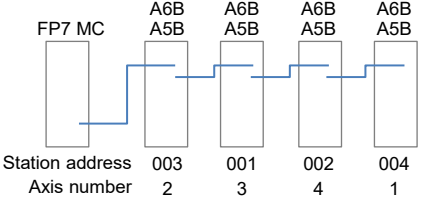
No.	Display of project explorer	Configuration of devices
①		<p>This shows the state the station addresses are the same as axis numbers, and set in the connection order.</p> 
②		<p>This shows the state the station addresses are the same as axis numbers, and set in the reverse order of the connection.</p> 
③		<p>The station addresses do not match the axis numbers.</p> 



◆ **KEY POINTS**

- When closing EtherCAT Configurator of CMI, an error message is displayed if station addresses or axis numbers are duplicated.

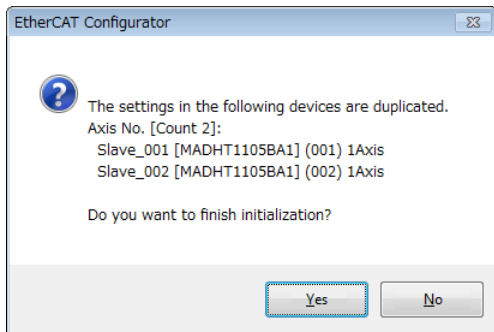

### 4.4.4 Download to FP7 MC Unit

Check the configuration of devices connected to the network, and download setting information to FP7 MC Unit after finishing the setting of station addresses and axis numbers. The following procedure is explained on the condition that CMI has already started.



#### ◆ PROCEDURE

1. Select "File" > "Download to Unit" from the menu bar.

A message confirming the target unit is displayed.

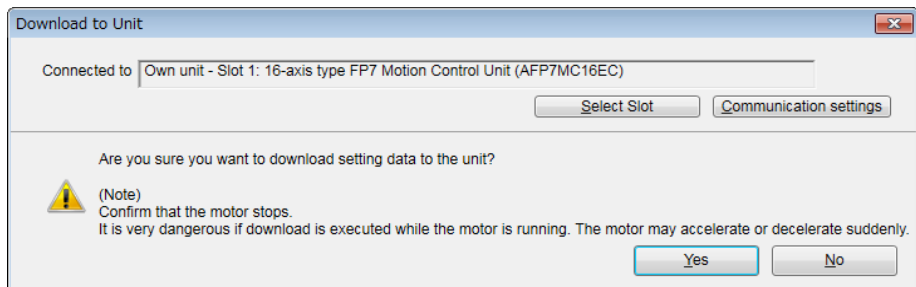

2. Confirm the message, and press the [Yes] button.

When the CPU is in RUN mode, the following message is displayed.

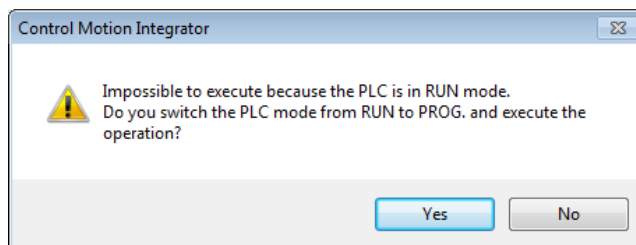

3. Select a unit to which the setting data is downloaded, and press the "Yes" button.

A message confirming whether to execute the writing to FROM is displayed.

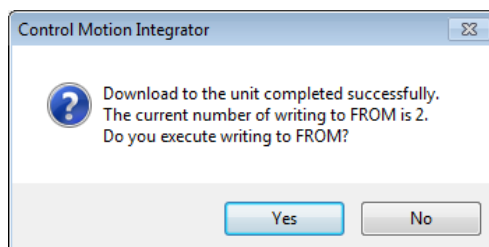

4. Press the [Yes] button to write data to the FROM in the unit, and press the [No] button not to perform the writing.

When the processing is finished, the following message is displayed.

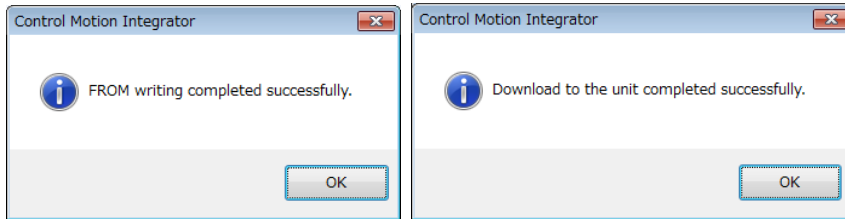

5. Press the [OK] button.

The message for confirming the mode switching of the CPU unit is displayed.

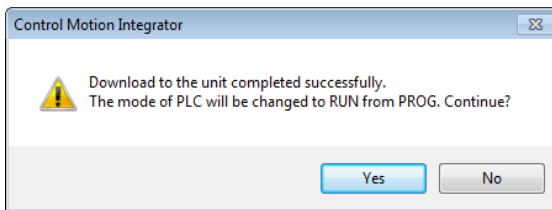

6. Press the [Yes] or [No] button.



---

#### ◆ KEY POINTS

---

- Executing "Writing to FROM" writes set parameters to the FROM in FP7 MC Unit. When the power turns on again, the parameters are read to the unit memory (RAM) from the FROM.
- When "Write to FROM" is not executed, the set parameters are temporarily written to the unit memory (RAM) in the unit and used as data during operation. However, when the power turns on again, they are overwritten by the parameters written into the FROM.
- It is also possible to execute "Online" > "Write to FROM" on CMI.
- "Write to FROM" can also be executed by turning on the FROM write request (Y3) of user programs. However, we recommend using differential execution with this instruction to prevent the writing from being executed continuously.



---

#### ◆ NOTES

---

- Writing to FROM can be performed up to 10000 times. Do not write data to FROM more than 10000 times.



---

### 4.4.5 Restarting Power Supplies and Checking Communication State

---

Download the parameters set by CMI to FP7 MC Unit, and then restart the power supplies for the system (Unit and Servo Amplifier). The setting is reflected and the communication is started.



---

#### ◆ PROCEDURE

---

1. Turn off the power supplies of FP7 MC Unit and Servo Amplifier A6B/A5B.
2. Turn on the power supply of Servo Amplifier A6B/A5B.
3. Turn on the power supply of FP7 MC Unit.

EtherCAT communication is started between Servo Amplifier A6B/A5B and FP7 MC Unit. Once the communication is executed and the link is established properly, the both "EC RUN" LEDs turn on.

4. Confirm that no error occurs.

When an error occurs, the ERR LED on FP7 MC Unit turns on.



---

#### ◆ KEY POINTS

---

- The connection state of the network can be checked by monitoring the unit memories. The information on abnormal slaves is stored in the unit memories (UM 0012E to UM 00139).
- When the configuration is different from the network configuration set by CMI, an error occurs.
- The participation wait time for the nodes (slaves) connected to the EtherCAT network can be set in the "MC common settings" menu of CMI after the power-on of FP7 MC Unit.

■ Unit memories (Slave tables)

●: Available, -: Not available

Slave no.	Unit memory no. (Hex)	Name	Default	Description	R	W
1-16	UM 000FE	Registered slave table	H0	Turns on bits corresponding to each station address (slave number) registered in ENI file.	●	-
17-32	UM 000FF					
-	-					
177-192	UM 00109					
1-16	UM 0010A	Network participating slave table	H0	Turns on the bits corresponding to each station address (slave number) in the OP mode out of the slaves participating in the network.	●	-
17-32	UM 0010B					
-	-					
177-192	UM 00115					
1-16	UM 00122	Normal slave table	H0	Turns on bits corresponding to each station address (slave number) in the OP mode out of the slaves registered in ENI file and participating in the network.	●	-
17-32	UM 00123					
-	-					
177-192	UM 0012D					
1-16	UM 0012E	Abnormal slave table	H0	Turns on bits corresponding to each station address (slave number) in any modes other than OP mode out of the slaves registered in ENI file and participating in the network.	●	-
17-32	UM 0012F					
-	-					
177-192	UM 00139					

(Note 1): Sixteen slave numbers are allocated to each area (1 word).

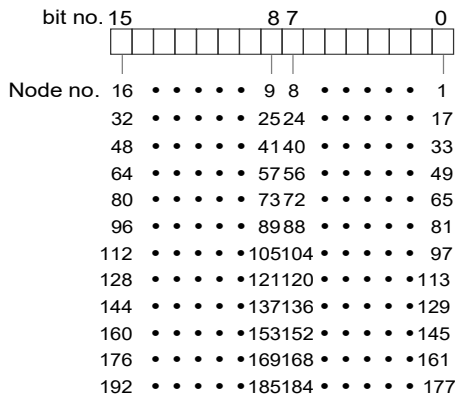

## 4.5 Connection of Limit and Near Home Switches

### 4.5.1 Connection of Input Signals

For the system which uses the over limit switches and near home switch, connect them to the I/O connector (X4) of Servo Amplifier A6B/A5B.

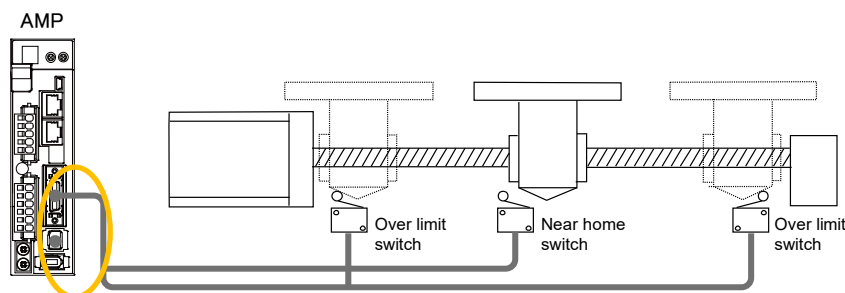

#### ■ I/O connector (X4): Allocation of functions at the factory setting

X4 connector		Function at the factory setting			Application on the FP7 MC Unit side
Name	Pin no.	Signal name	Code	Logic	
SI1	5	General-purpose monitor input 5	SI-MON5	A contact	It can be only monitored by the unit memories.
SI2	7	CW over-travel inhibit input	POT	B contact	
SI3	8	CCW over-travel inhibit input	NOT	B contact	Do not allocate POT or NOT.
SI4	9	Near home input	HOME	A contact	
SI5	10	External latch input 1	EXT1	A contact	It can be only monitored by the unit memories.
SI6	11	External latch input 2	EXT2	A contact	
SI7	12	General-purpose monitor input 3	SI-MON3	A contact	It is used as a limit +.
SI8	13	General-purpose monitor input 4	SI-MON4	A contact	It is used as a limit -.

(Note 1): The above table shows the allocation before shipment. It varies according to the setting of PANATERM.



#### ◆ KEY POINTS

- When using FP7 MC Unit in combination with Servo Amplifier A6B/A5B, the general-purpose inputs (SI-MON3 and SI-MON4) are used as limit inputs. For using the general-purpose monitor inputs (SI-MON3 and SI-MON4) as limit inputs, the setting of the limit switch should be set to "A: Enabled" in the "Axis parameter setting" menu of CMI.
- The over-travel inhibit inputs (POT, NOT) cannot be used as the limit inputs on the MC Unit side. Do not allocate the over-travel inhibit inputs (POT, NOT) to the I/O connector (X4) of Servo Amplifier A6B/A5B.

## 4.5.2 Pin Assignment Setting of Servo Amplifier

The allocation of I/O connector (X4) and input logic is set by PANATERM. The following procedure is explained on the condition that PANATERM has already started.



### ◆ PROCEDURE

1. Select "Other" > "Pin Assign" from the toolbar.

The "Pin Assign" dialog box is displayed.

Pin number	Position / Full-closed control	Velocity control	Torque control
05 (SI1)	SI-MON5_ConnectA	SI-MON5_ConnectA	SI-MON5_ConnectA
07 (SI2)	POT_ConnectB	POT_ConnectB	POT_ConnectB
08 (SI3)	NOT_ConnectB	NOT_ConnectB	NOT_ConnectB
09 (SI4)	HOME_ConnectA	HOME_ConnectA	HOME_ConnectA
10 (SI5)	EXT1_ConnectA	EXT1_ConnectA	EXT1_ConnectA
11 (SI6)	EXT2_ConnectA	EXT2_ConnectA	EXT2_ConnectA
12 (SI7)	SI-MON3_ConnectA	SI-MON3_ConnectA	SI-MON3_ConnectA

2. Double-click the row "Pin number 07 (SI2)" to which "POT" is allocated.

The "Input function select" dialog box is displayed.

Position / Full-closed	Velocity control	Torque control
Invalid	Invalid	Invalid
POT	POT	POT
NOT	NOT	NOT
-	-	-
A-CLR	A-CLR	A-CLR
-	-	-
-	-	-
-	-	-
-	-	-
-	-	-

3. Select the row "Invalid", and press the [OK] button.

The change result can be confirmed in the "Pin Assign" dialog box.

4. Repeat steps 2 and 3 for "NOT: Pin number 08 (SI3)".
5. When changing the input logics of limit and near home switches, go to step 6. When they are not changed, go to step 10.
6. Double-click the row in which the general-purpose monitor input "SI-MON3" is allocated.

The "Input function select" dialog box is displayed.

7. Confirm "SI-MON3" is selected, switch the three radio buttons from "A-Connect" to "B-Connect", and press the [OK] button.

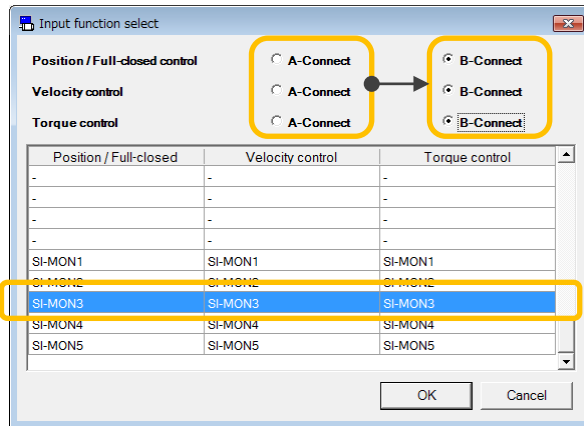

The change result can be confirmed in the "Pin Assign" dialog box.

8. Repeat the same operations in steps 6 and 7 for "SI-MON4", too.
9. When changing the input logic of near home switch, repeat the same operations.
10. Press the [Apply] button in the "Pin Assign" dialog box.

A confirmation message is displayed.

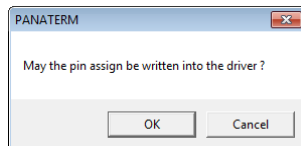

11. Press the [OK] button.

A confirmation message is displayed.

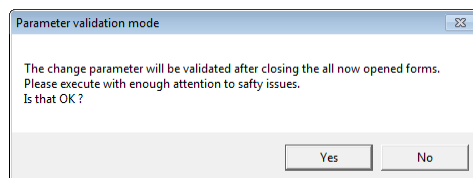

12. Press the [Yes] button.

Writing to the EEPROM to the servo amplifier is executed.



**◆ KEY POINTS**

- When FP7 MC Unit is being controlled, the following message is displayed.

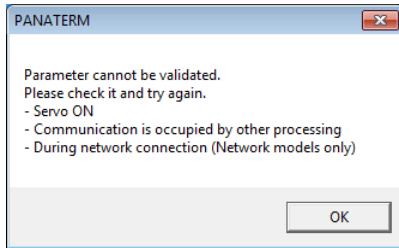

### 4.5.3 Checking Servo Amplifier Input State

After the completion of the pin assign setting of Servo Amplifier, operate the connected limit inputs and near home inputs forcibly and check the input states. The input states can be checked on PANATERM.

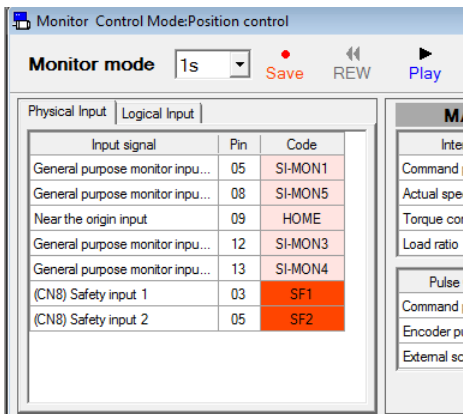

### 4.5.4 Settings of FP7 MC Unit

To enable the limit function, the axis parameter "Limit input" in CMI should be set to be enabled. Also, the input logic should be confirmed on CMI.

■ Settings related to limit switch

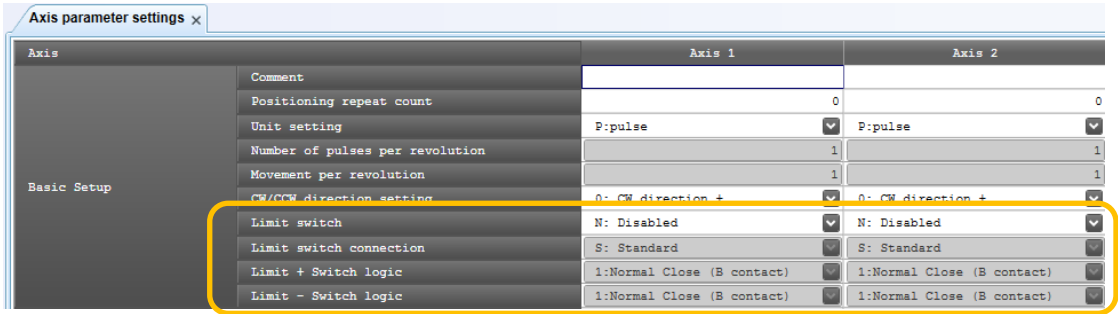

Parameter name	Default	Description
Limit switch	N: Disabled	When using the limit switch function or the home return function using limit switches, select "A: Enabled". N: Disabled, A: Enabled
Limit switch connection	S: Standard	When the arrangement of the connected "limit + switch" and "limit - switch" is opposite to the input state loaded to FP7 MC Unit, select "R: Reverse connection". S: Standard, R: Reverse connection
Limit + switch logic	1: Normal Close (B contact)	Select the input logic of the limit switches.
Limit - switch logic		0: Normal Open (A contact), 1: Normal Close (B contact)



◆ KEY POINTS

- In the system using FP7 MC Unit, limit switches are connected to the general-purpose inputs (SI-MON3 and SI-MON4) of Servo Amplifier A6B/A5B. When the "Limit switch" is set to "Enabled" in the above parameter, the state of the general-purpose inputs (SI-MON3 and SI-MON4) of Servo Amplifier A6B/A5B is reflected as the limit inputs of FP7 MC Unit.
- It is recommended to select "Normal Open (A contact)" for "Limit + Switch logic" and "Limit - Switch logic". The input logic selected on Servo Amplifier A6BA5B is reflected as is.



◆ REFERENCE

- For details of the axis parameter settings, refer to "5.2 Axis Parameter Settings".

### ■ Setting of home position proximity logic

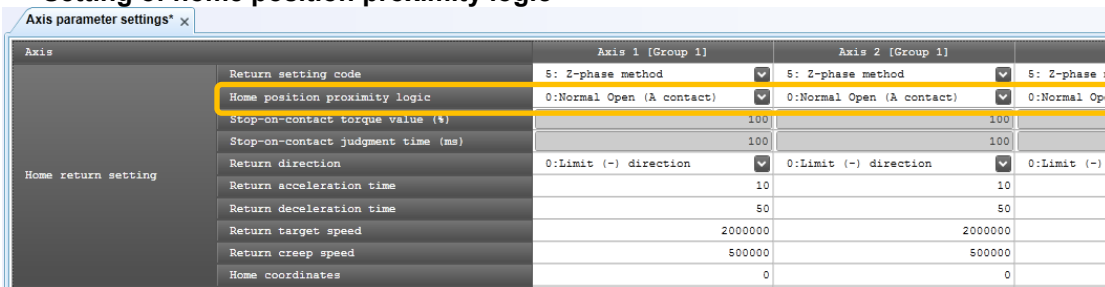

Parameter name	Default	Description
Home position proximity logic	0: Normal Open (A contact)	The near home input logic is selected. 0: Normal Open (A contact), 1: Normal Close (B contact)



#### ◆ KEY POINTS

- It is recommended to select "Normal Open (A contact)" for "Home position proximity logic". The input logic selected on Servo Amplifier A6B/A5B is reflected as is.

### 4.5.5 Download to FP7 MC Unit

Once the settings of limit switches and input logic are completed in CMI, download the parameter information to FP7 MC Unit.



#### ◆ REFERENCE

- For details of the downloading method, refer to "4.4.4 Download to FP7 MC Unit".

### 4.5.6 Checking Input State

After the completion of the settings, operate the limit inputs and near home inputs connected to the servo amplifier forcibly, checker that they can be monitored on the FP7 MC Unit side.

- They can be monitored by the status monitor or unit memories (input control area).
- The unit memories of FP7 MC Unit can also be monitored when FP7 CPU Unit is in PROG. mode.



## 4.6 Saving and Managing Files

### 4.6.1 File Type

The set parameters and positioning table information can be saved or exported in the following four formats.

File name	Extension	Application	Operation
CMI file	.cmi	The whole parameters of FP7 MC Unit are saved. <ul style="list-style-type: none"> <li>● EtherCAT communication parameters</li> <li>● Setting of Positioning Parameters</li> <li>● Setting of positioning tables</li> </ul>	Save Open
Project file	.ecc	Project files (EtherCAT communication parameters) created by EtherCAT Configurator in CMI are saved.	Save Open
ENI file	.xml	ENI files created by EtherCAT Configurator in CMI are exported/imported.	Export Import
CSV file	.csv	The whole parameters of FP7 MC Unit are exported in csv format. They can be used for checking parameters.	Export

### 4.6.2 Saving as CMI Files

Set parameters and positioning table information can be saved and opened on CMI. The saved data can also be reused in multiple units and projects.



#### ◆ PROCEDURE

1. Select **"File" > "Save As"** from the menu bar.

The "Save As" dialog box is displayed.

2. Enter a saving destination and file name, and press **[Save]** button.

Information on parameters and positioning tables is saved as files with the extension (.cmi).



#### ◆ KEY POINTS

- The files saved by the above operations contain the information on all parameters and positioning tables set on CMI.

### 4.6.3 Export to CSV Files

---

The information on set parameters and positioning tables can be exported in csv format. It is possible to open the csv files and check the settings of each parameter and positioning table.



#### ◆ PROCEDURE

---

1. Select "File" > "Export to CSV" from the menu bar.

The "Export to CSV" dialog box is displayed.

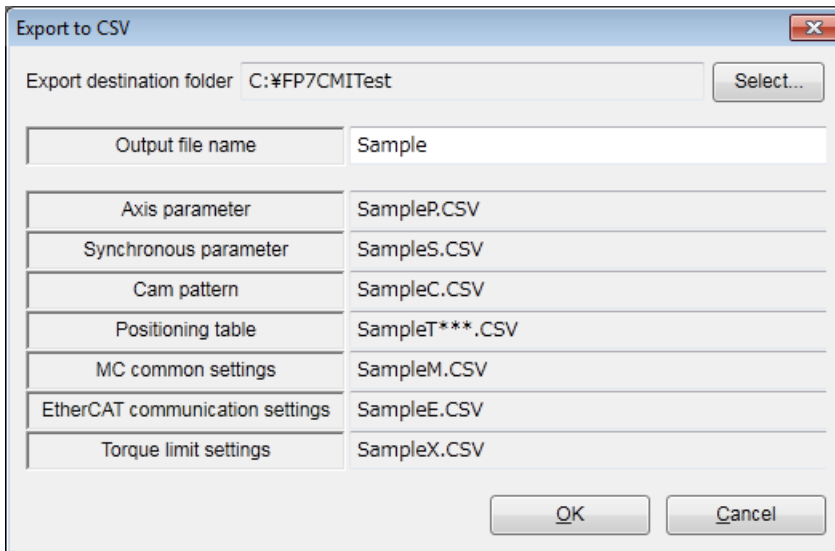

2. Enter an output file name, and press the [OK] button.

CSV files with given file names are saved for each parameter.

# 5

## Settings of FP7 MC Unit Using CMI Tool

## 5.1 FP7 MC Unit Common Settings

### 5.1.1 FP7 MC Unit Common Settings Dialog Box

In the "MC common settings" dialog box, The EtherCAT communication cycle and the operations when errors occur are set. The following procedure is explained on the condition that CMI has already started.



#### ◆ PROCEDURE

1. Select "Parameter" > "MC common settings" from the menu bar.

The "MC common settings" dialog box is displayed.

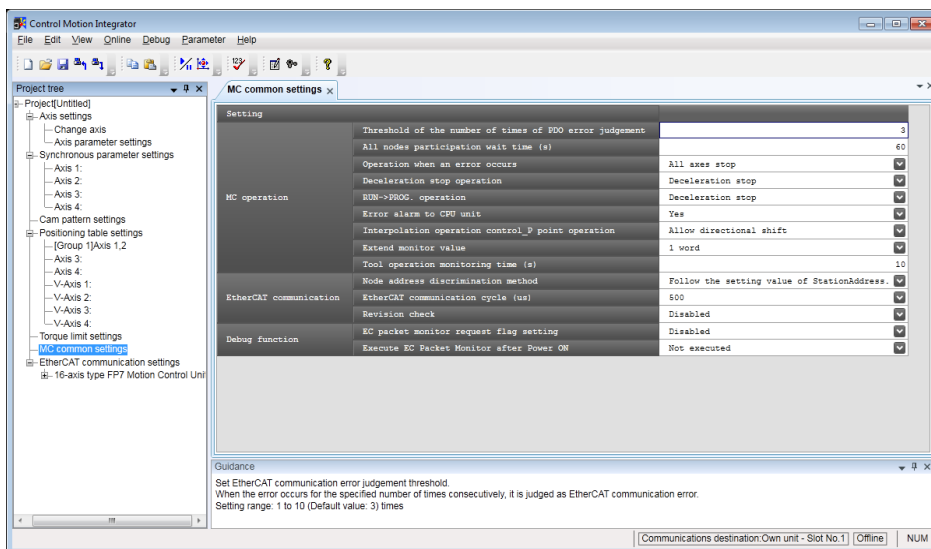

2. Set necessary parameters in accordance with the intended use.



#### ◆ KEY POINTS

- Although the data being edited is held until finishing CMI even when the dialog box is closed with the X mark during the editing, save parameters by executing "File" > "Save As" as necessary.

## 5.1.2 FP7 MC Unit Common Settings Parameters

The Parameters common to the unit, such as error judgement conditions and operation when errors occur, are set.

### ■ MC operation

Parameter name	Default	Description
Threshold of the number of times of PDO error judgement	3	The EtherCAT communication error judgement threshold is set. When the error occurs for the specified number of times consecutively, it is judged as EtherCAT communication error. Range: 1 to 10 (times)
All nodes participation wait time (s)	60	The participation wait time for slaves connected to EtherCAT network after MC Unit is powered on is set. Error occurs when a node does not participate in the network after the elapse of the specified time. Range: 1 to 240 (s)
Operation when an error occurs	All axes stop	The operation performed when an error occurs in axes (nodes) connected to the network is set.  All axes stop      All axes operations stop. The operations of normal axes stop in the deceleration time activated when an error occurs.  Normal axis operation continuance (Degraded operation)      The operation of the axis an error occurred stops. The operations of normal axes continue.
Deceleration stop operation UM 0261D	Deceleration stop	In the case of positioning control, the function when the deceleration stop request of unit memories (output control area) turns on is set. Deceleration stop / Pause
RUN->PROG. operation	Deceleration stop	The operation when the operation mode of CPU unit changes from RUN to PROG is set.  Operation continuance      The operation of each axis continues.  Deceleration stop      Each axis decelerates and stops in a specified deceleration stop time in the current control mode.  Immediate stop      Each axis decelerates and stops in a specified emergency stop deceleration time.
Error alarm to CPU unit	Yes	The error annunciation method to FP7 MC Unit when an error occurs is set.  Yes      Announces errors to the CPU unit. No      Not announce errors to the CPU unit.
Interpolation operation control _P-point operation	Allow directional shift	Set whether or not to allow the shift between the moving direction (vector) to a target point from the operation starting point and the moving direction (vector) to the next target point during the P-point operation of interpolation operation control.  Allow directional shift      P-point operation continues even when the moving direction is displaced.  Not allow directional shift      Operation is performed by replacing P-point with C-point when the moving amount shifts.
Extend monitor value	1 word	"Movement amount automatic check threshold", "Actual speed judgement value" and "Actual speed monitor value" can be extended. 1 word: Not extend 2 words: Extend
Tool operation monitoring time (s)	10	The communication timeout period between CMI and FP7 MC Unit is set. Range: 1 to 240 (s)

➡ next page

■ EtherCAT communication

Parameter name	Default	Description						
Node address discrimination method	Follow the setting value of Station Address.	Select a node address discrimination method.						
		<table border="1"> <thead> <tr> <th>Setting</th> <th>Function</th> </tr> </thead> <tbody> <tr> <td>Follow the setting value of Station Address.</td> <td>Set by the station address in the "General" tab in the EtherCAT communication setting by the software CMI.</td> </tr> <tr> <td>Follow the node address discrimination method of each slave.</td> <td>Set node addresses by the station alias setting of the servo amplifier.</td> </tr> </tbody> </table>	Setting	Function	Follow the setting value of Station Address.	Set by the station address in the "General" tab in the EtherCAT communication setting by the software CMI.	Follow the node address discrimination method of each slave.	Set node addresses by the station alias setting of the servo amplifier.
		Setting	Function					
Follow the setting value of Station Address.	Set by the station address in the "General" tab in the EtherCAT communication setting by the software CMI.							
Follow the node address discrimination method of each slave.	Set node addresses by the station alias setting of the servo amplifier.							
EtherCAT communication cycle (μs)	500	Select the EtherCAT communication cycle. 500 / 1000 / 2000 / 4000 (μs)						
Revision check	Disable	<p>Set the revision number checking method for slave devices. Select from the following items.</p> <p>Disable                      Not check revision numbers.</p> <p>Common to all axes (HW==)      Check revision numbers of all slave devices in the same method (high word match).</p> <p>Common to all axes (==)      Check revision numbers of all slave devices in the same method (all match).</p> <p>Common to all axes (LW==)      Check revision numbers of all slave devices in the same method (low word match).</p> <p>Individual axis setting      Execute according to the revision number checking method for each slave device.</p>						

(Note): Set the EtherCAT communication cycle in accordance with the following contents. The installation condition is the case by our measurement condition.

Control method	No. of used axes	Setting value
Single axis control	Up to 5 axes	From 500 (μs)
	Up to 16 axes	From 1000 (μs)
	Up to 32 axes	From 2000 (μs)
	Up to 64 axes	4000 (μs)
Interpolation control Synchronous control	Up to 4 axes	From 500 (μs)
	Up to 16 axes	From 1000 (μs)
	Up to 32 axes	From 2000 (μs)
	Up to 64 axes	4000 (μs)

### ■ Debug function

Parameter name	Default	Description
EC packet monitor request flag setting	Disabled	<p>The operation of packet monitor request flag of EC(EtherCAT) communication is set.</p> <p>Disabled    Packet monitor is not executed when EC packet monitor request flag turns on.</p> <p>Enabled    Packet monitor is executed when EC packet monitor request flag turns on.</p>
Execute EC Packet Monitor after Power ON	Not executed	<p>The operation of the EC (EtherCAT) packet monitor when FP7 MC Unit is powered on is set.</p> <p>Not executed    EC packet monitoring is not executed after the power turns on.</p> <p>Executed    EC packet monitoring is executed after the power turns on.</p>



### ◆ REFERENCE

- For details of "EC packet monitor" function, refer to "13.13 EC Packet Monitor Function".

## 5.2 Axis Parameter Settings

### 5.2.1 Setting by CMI

The parameters common to each axis, such as the motor rotation direction and the logics of near home input and limit input, are set by CMI. The following procedure is explained on the condition that CMI has already started.



#### ◆ PROCEDURE

1. Select "Parameter" > "Axis parameter settings" from the menu bar.

The "Axis parameter settings" dialog box is displayed.

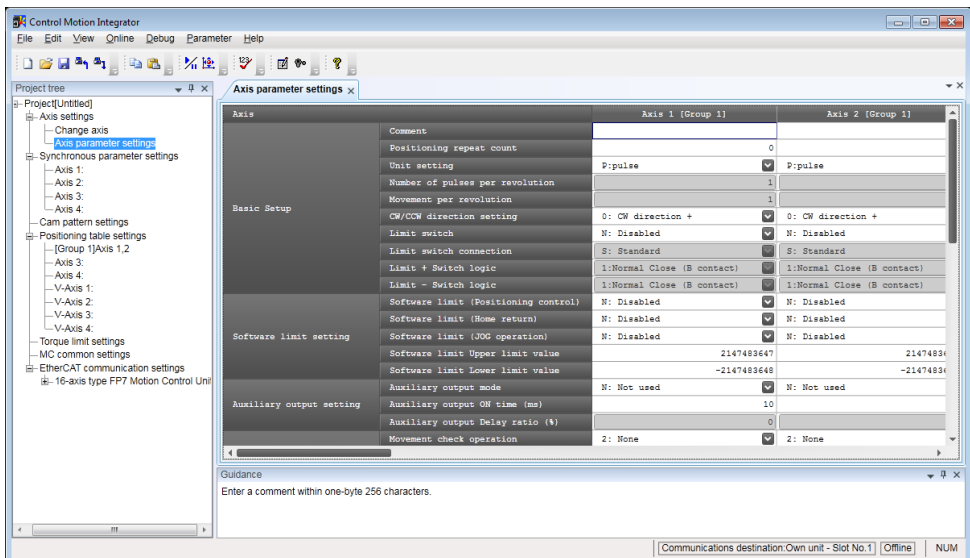

2. Set necessary parameters in accordance with the intended use.
3. Select "File" > "Save As" from the menu bar.
4. Enter an arbitrary file name, and press the [Save] button.



#### ◆ KEY POINTS

- Although the data being edited is held until finishing CMI even when the dialog box is closed with the X mark during the editing, save parameters by executing "File" > "Save As".



## 5.2.2 Axis Parameters (Basic Setup)

### ■ Basic Setup

Parameter name	Default	Description
Comment	Blank	Arbitrary comments can be input. Comments can be stored in FP7 MC Unit since Ver.1.2.
Positioning repeat count UM 009F0	0	The number of repetitions of positioning control is set. Range: 0 to 255 times Repeat count: When it is 0 or 1, the positioning operation is not repeated. Repeat count: In the case of 255, operation is repeated unlimitedly.
Unit setting UM 03240	P: pulse	The units for specifying position command values and speed command values are set. P: pulse M: $\mu\text{m}$ [Min 0.1], M: $\mu\text{m}$ [Min 1] I: inch [Min 0.00001 inches], I: inch [Min 0.0001 inches ] D: degree [Min 0.1], D: degree [Min 1]
Number of pulses per revolution UM 03242-UM 03243	1	Only when the unit is set to um, inch, or degree, the pulse number and movement amount per revolution are set. The ranges vary depending on the unit settings as below.
Movement per revolution UM 03244-UM 03245	1	$\mu\text{m}$ : 1 $\mu\text{m}$ inch: 1/10,000 inch degree: 1 degree
CW/CCW direction setting UM 03254 bit1	0: CW direction +	0: CW direction +: Set the direction that an elapsed value is + as CW. 1: CCW direction +: Set the direction that an elapsed value is + as CCW.
Limit switch UM 03254 bit0	N: Disabled	When using the limit switch function or the home return function using limit switches, select "A: Enabled". N: Disabled, A: Enabled
Limit switch connection UM 03254 bit2	S: Standard	When the arrangement of the connected "limit +" and "limit -" is opposite to the input state loaded to FP7 MC Unit, select "R: Reverse connection". S: Standard, R: Reverse connection
Limit + Switch logic UM 03254 bit4	1: Normal Close (B contact)	Select the input logic of the limit switches. 0: Normal Open (A contact), 1: Normal Close (B contact)
Limit - Switch logic UM 03254 bit5		

(Note): The values set in these parameters are stored in the unit memory numbers described below the parameter names.



### ◆ KEY POINTS

- In FP7 MC Unit, CW refers to the rotating direction with a count increase and CCW refers to the direction with a count decrease. Therefore, limit input in the CW direction is limit + input and that in the CCW direction is limit -.
- In the system using FP7 MC Unit, limit switches are connected to the general-purpose inputs (SI-MON3 and SI-MON4) of Servo Amplifier A6B/A5B. When the "Limit switch" is set to "Enabled" in the above parameter, the state of the general-purpose inputs (SI-MON3 and SI-MON4) of Servo Amplifier A6B/A5B is reflected as the limit inputs of FP7 MC Unit.
- It is recommended to select "Normal Open (A contact)" for "Limit + Switch logic" and "Limit - Switch logic". The input logic selected on the Servo Amplifier A6B/A5B side is reflected as is.

### 5.2.3 Axis Parameters (Options)

These parameters are set according the used functions.

#### ■ Software limit setting

Parameter name	Default	Description
Software limit (Positioning control) UM 0324B bit0	N: Disabled	Select whether to enable or disable the software limit when executing the positioning control, home return or JOG operation. N: Disabled, A: Enabled
Software limit (Home return) UM 0324B bit1	N: Disabled	
Software limit (JOG operation) UM 0324B bit2	N: Disabled	
Software limit Upper limit value UM 0324C - UM0324D	2147483647	Set the upper or lower limit of the software limit.
Software limit Lower limit value UM 0324E - UM 0324F	-2147483648	

(Note): The values set in these parameters are stored in the unit memory numbers described below the parameter names.

#### ■ Auxiliary output setting

Parameter name	Default	Description
Auxiliary output mode UM 03252 bit7-0	N: Not used	Select the operation mode of auxiliary output contact and auxiliary output code. N: Not used, W: With mode, D: Delay mode
Auxiliary output ON time (ms) UM 03252 bit15-8	10	Set the time period that auxiliary output contact is ON. Range: 0 to 255 ms
Auxiliary output delay ratio (%) UM 03253	0	When using the delay mode for the auxiliary output, specify the ratio to output. Range: 0 to 100 %

(Note): The values set in these parameters are stored in the unit memory numbers described below the parameter names.

### ■ Monitor setting

Parameter name	Default	Description											
Movement check operation UM 0324A	2: None	Select the operation when exceeding the movement amount automatic check threshold. 0: Error, 1: Warning, 2: None											
Movement check value (pulse) UM 03258-UM 03259	10000	Set the threshold for the movement amount automatic check operation. (Note) <table border="1"> <thead> <tr> <th>Extend monitor value</th> <th>Range</th> </tr> </thead> <tbody> <tr> <td>1 word</td> <td>0 to 65535 pulses</td> </tr> <tr> <td>2 words</td> <td>0 to 2147483647 pulses</td> </tr> </tbody> </table>	Extend monitor value	Range	1 word	0 to 65535 pulses	2 words	0 to 2147483647 pulses					
Extend monitor value	Range												
1 word	0 to 65535 pulses												
2 words	0 to 2147483647 pulses												
Completion width check time (ms) UM 03257	0	Specify the width of the completion of command operation. When "0" is set, the completion width is not checked. Range: 0 to 10,000 ms											
Completion width (pulse) UM 0325A-UM 0325B	10	Turns on the completion flag when the AMP current value [feedback value] becomes within this completion width after the movement of a set amount during the positioning control, JOG operation. Range: 1 to 2,147,483,647 Any other settings will be errors.											
Monitor error - Torque judgement UM 0325C bit1-0	N: Disabled	Select the operation of FP7 MC Unit when the torque value of the amplifier is monitored and exceeds the judgement value. N: Disabled, E: Enabled (Error), W: Enabled (Warning)											
Monitor error- Torque judgement value (%) UM 0325D	5000	Set the torque judgement value. Range: 0 to 5000 (0.0 % to 500.0 %)											
Monitor error - Actual speed judgement UM 0325C bit3-2	N: Disabled	Select the operation of FP7 MC Unit when the actual speed of the amplifier is monitored and exceeds the judgement value. N: Disabled, E: Enabled (Error), W: Enabled (Warning)											
Monitor error - Actual speed judgement value unit UM 0325C bit4	0: 0.1 rpm	When "2 words" is set for "Extend monitor value", set the unit for the monitor error actual speed judgement. (Note) 0: 0.1 rpm 1: Command unit/s											
Monitor error - Actual speed judgement value UM 0325E-UM 0325F	5000	Set the actual speed judgement value. (Note) <table border="1"> <thead> <tr> <th>Extend monitor value</th> <th>Monitor error unit</th> <th>Range</th> </tr> </thead> <tbody> <tr> <td>1 word</td> <td>1 rpm</td> <td>0 to 5000 rpm</td> </tr> <tr> <td rowspan="2">2 words</td> <td>0.1 rpm</td> <td>0 to 6500.0 rpm</td> </tr> <tr> <td>Command unit/s</td> <td>2147483647 command unit/s</td> </tr> </tbody> </table>	Extend monitor value	Monitor error unit	Range	1 word	1 rpm	0 to 5000 rpm	2 words	0.1 rpm	0 to 6500.0 rpm	Command unit/s	2147483647 command unit/s
Extend monitor value	Monitor error unit	Range											
1 word	1 rpm	0 to 5000 rpm											
2 words	0.1 rpm	0 to 6500.0 rpm											
	Command unit/s	2147483647 command unit/s											

(Note): The values set in these parameters are stored in the unit memory numbers described below the parameter names.



### ◆ REFERENCE

- For details of each function of software limit, auxiliary output and monitor setting, refer to "13 Supplementary Functions".
- For details of the "Extend monitor value" setting, refer to "5.1.2 FP7 MC Unit Common Settings Parameters".

## 5.2.4 Axis Parameters (Operation)

Common parameters to each axis related to operations are set.

### ■ Home return setting

Parameter name	Default	Description
Return setting code UM 03260	0: DOG method 1	Select the pattern of home return. 0: DOG method 1 (Based on front end + Z phase) 1: DOG method 2 (Based on front end) 2: DOG method 3 (Based on back end + Z phase) 9: DOG method 4 (Based on back end) 3: Limit method 1 (Limit signal + Z phase) 4: Limit method 2 (Limit signal) 5: Z phase method 6: Stop-on-contact method 1 7: Stop-on-contact method 2 (Stop-on-contact + Z phase) 8: Data set method
Home position proximity logic UM 03254 bit3	0: Normal Open (A contact)	Select the near home input logic. 0: Normal Open (A contact) 1: Normal Close (B contact)
Stop-on-contact torque value (%) UM 0327D	100 (10.0%)	This parameter is used for selecting the stop-on-contact method as the home return method. It is regarded as a criterion for judging the home return once the torque value of the servo amplifier exceeded this set value by the stop-on-contact. Range: 0 to 5000 (0.0 % to 500.0 %)
Stop-on-contact judgment time (ms) UM 0327E	100	This parameter is used for selecting the stop-on-contact method as the home return method. When using the stop-on-contact method, it is regarded as a criterion for judging the home return once this set time has passed after the torque value of the servo amplifier exceeded the stop-on-contact torque value. Range: 0 to 10000 (ms)
Return direction UM 03261	0: Limit (-) direction	Select the operation direction of home return. 0: Elapsed value decreasing direction (Limit - direction) 1: Elapsed value increasing direction (Limit + direction)
Return acceleration time (ms) UM 03262	100	Set the acceleration time when performing the home return. Range: 0 to 10000 (ms)
Return deceleration time (ms) UM 03263	100	Set the deceleration time when performing the home return. Range: 0 to 10000 (ms)
Return target speed UM 03264-UM 03265	1000	Set the target speed when performing the home return. Range: 1 to 2,147,483,647
Return creep speed UM 03266-UM 03267	100	Set the creep speed to search the home position in the home return operation. Range: 1 to 2,147,483,647
Home coordinates UM 0328E-UM 0328F	0	Set the home coordinates to be set after the completion of the home return. Range: -2,147,483,648 to 2,147,483,647  The ranges vary depending on the unit settings as below. pulse: -2,147,483,648 to 2,147,483,647 pulses $\mu\text{m}$ (0.1 $\mu\text{m}$ ): -214,748,364.8 to 214,748,364.7 $\mu\text{m}$ $\mu\text{m}$ (1 $\mu\text{m}$ ): -2,147,483,648 to 2,147,483,647 $\mu\text{m}$ inch (0.0001 inch): -21,474.83648 to 21,474.83647 inches inch (0.0001 inch): -214,748.3648 to 214,748.3647 inches degree (0.1 degree): -214,748,364.8 to 214,748,364.7 degrees degree (1 degree): -2,147,483,648 to 2,147,483,647 degrees

(Note): The values set in these parameters are stored in the unit memory numbers described below the parameter names.



## ◆ KEY POINTS

- It is recommended to select "Normal Open (A contact)" for "Home position proximity logic". The input logic selected on Servo Amplifier A6B/A5B is reflected as is.

### ■ JOG operation setting

Parameter name	Default	Description
Acceleration/deceleration pattern setting UM 03269 bit1	0: Linear acceleration/deceleration	Select the acceleration/deceleration pattern when performing the JOG operation. 0: Linear acceleration/deceleration 1: S-shaped acceleration/deceleration
JOG acceleration time (ms) UM 0326A	100	Set the acceleration time when performing the JOG operation. Range: 0 to 10000 (ms)
JOG deceleration time (ms) UM 0326B	100	Set the deceleration time when performing the JOG operation. Range: 0 to 10000 (ms)
JOG target speed UM 0326C-UM 0326D	1000	Set the target speed for performing the JOG operation. Range: 1 to 2,147,483,647 Any other settings will be errors.  The ranges vary depending on the unit settings as below. pulse: 1 to 2,147,483,647 pps $\mu$ m: 1 to 2,147,483,647 $\mu$ m/s inch: 0.001 to 2,147,483.647 inch/s degree: 0.001 to 2,147,483.647 rev/s
JOG operation - Inching movement UM 0326E-UM 0326F	1	Set the movement amount when starting JOG inching operation. Range: 1 to 2147483647  The ranges vary depending on the unit settings as below. pulse: 1 to 2,147,483,647 pulses $\mu$ m (0.1 $\mu$ m): 0.1 to 214,748,364.7 $\mu$ m $\mu$ m (1 $\mu$ m): 1 to 2,147,483,647 $\mu$ m inch (0.00001 inch): 0.00001 to 21,474.83647 inches inch (0.0001 inch): 0.0001 to 214,748.3647 inches degree (0.1 degree): 0.1 to 214,748,364.7 degrees degree (1 degree): 1 to 2,147,483,647 degrees

(Note): The values set in these parameters are stored in the unit memory numbers described below the parameter names.

### ■ Stop function setting

Parameter name	Default	Description
Emergency stop deceleration time (ms) UM 03273	100	Set the deceleration time at the time of emergency stop. Range: 0 to 10000 (ms)
Limit stop deceleration time (ms) UM 03275	100	Set the deceleration time at the time of limit stop. Range: 0 to 10000 (ms)
Error stop deceleration time (ms) UM 03277	100	Set the deceleration time at the time of error stop. Range: 0 to 10000 (ms)

(Note): The values set in these parameters are stored in the unit memory numbers described below the parameter names.

**Settings of FP7 MC Unit**  
Using CMI Tool

■ **J-point operation setting**

Parameter name	Default	Description
Operation setting code UM 03281 bit1	0: Linear acceleration/ deceleration	Select the acceleration/deceleration pattern when performing the J-point control 0: Linear acceleration/deceleration 1: S-shaped acceleration/deceleration
Acceleration time (ms) UM 03282	100	Set the acceleration time when performing the J-point control. Range: 0 to 10000 (ms)
Deceleration time (ms) UM 03283	100	Set the deceleration time when performing the J-point control. Range: 0 to 10000 (ms)
Target speed UM 03284-UM 03285	1000	Set the target speed when performing the J-point control. Range: 1 to 2,147,483,647 Any other settings will be errors.  The ranges vary depending on the unit settings as below. pulse: 1 to 2,147,483,647 pps $\mu$ m: 1 to 2,147,483,647 $\mu$ m/s inch: 0.001 to 2,147,483.647 inch/s degree: 0.001 to 2,147,483.647 rev/s

(Note): The values set in these parameters are stored in the unit memory numbers described below the parameter names.

## 5.3 Positioning Table Setting

### 5.3.1 Construction of Positioning Tables

Positioning tables are assigned using CMI. The following procedure is explained on the condition that CMI has already started.

#### ■ Positioning table setting screen of CMI

- Sheets are divided for each axis, and 1000 tables ranging no. 1 to no. 1000 can be set.
- By double-clicking an arbitrary axis of the project tree in CMI, the positioning data table opens.
- When setting the interpolation control, the cell for "Interpolation operation" as a selection item is added between Operation pattern and Control method. Also, the input cells for Movement amount and Auxiliary point are added according to the number of axes.

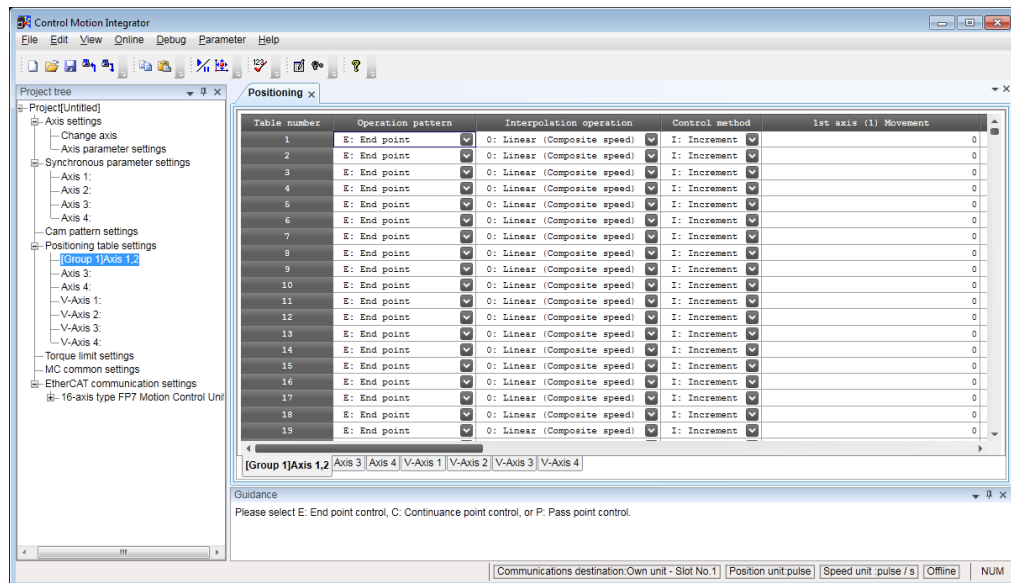

In the above example, the real axes 1 to 16 and virtual axes 1 to 8 are displayed.



#### ◆ REFERENCE

- For details of each control, refer to "8 Automatic Operation (Position Control)".

**Settings of FP7 MC Unit**  
Using CMI Tool

■ **Setting items (Common)**

Parameter name	Default	Description
Operation pattern	E: End point	Select one from the following operation patterns. E: End point, C: Continuance point, P: Pass point, J: Speed point
Control method	I: Increment	Select the control method. I: Increment, A: Absolute
1st axis (L) movement amount	0	Input the movement amount (position command value). The movement amount depends on the unit system specified in the parameter settings. Axis numbers are displayed in (L). Range: -2147483648 to 2147483647
Acceleration/ deceleration type	L: Linear	Select the acceleration/deceleration method. L: Linear, S: S-shaped
Acceleration time (ms)	100	Set the acceleration time. Range: 1 to 10000 (ms)
Deceleration time (ms)	100	Set the deceleration time. Range: 1 to 10000 (ms)
Target speed	1000	Set the target speed. Range: 1 to 2,147,483,647 Any other settings will be errors. The ranges vary depending on the unit settings as below. pulse: 1 to 2,147,483,647 pps μm: 1 to 2,147,483,647 μm/s inch: 0.001 to 2,147,483.647 inch/s degree: 0.001 to 2,147,483.647 rev/s
Dwell time (ms)	0	Set the time from the completion of the positioning instruction in the E-point control until the positioning done flag turns on. For the C-point control, it is the wait time between each table. For the P-point control, the dwell time is ignored.
Auxiliary output	0	Set the auxiliary output code. When the auxiliary output is set to be enabled in the parameter settings, the auxiliary output code specified here is output.
Comment	-	Arbitrary comments can be input for each table. Comments can be stored in FP7 MC Unit since Ver.1.2.

■ **Setting items (Additional items for 2-axis interpolation)**

Parameter name	Default	Description
Interpolation operation	0: Linear (Composite speed)	Select one from the following operation patterns. 0: Linear (Composite speed) 1: Linear (Major axis speed) S: Circular (Center point / CW direction) T: Circular (Center point / CCW direction) U: Circular (Pass point)
1st axis (L) Movement amount	0	Input the movement amount (position command value). The auxiliary point is input for the circular interpolation.  The axis numbers allocated to interpolation groups are displayed in (L) and (m) in the ascending order from the smaller number.
1st axis (L) Auxiliary point	0	
2nd axis (m) Movement amount	0	
2nd axis (m) Auxiliary point	0	



### ■ Setting items (Additional items for 3-axis interpolation)

Parameter name	Default	Description
Interpolation operation	0: Linear (Composite speed)	Select one from the following operation patterns. 0: Linear (Composite speed) 1: Linear (Major axis speed) A: Spiral (Center point / CW direction / 1st axis feed) B: Spiral (Center point / CCW direction / 1st axis feed) C: Spiral (Center point / CW direction / 2nd axis feed) D: Spiral (Center point / CCW direction / 2nd axis feed) E: Spiral (Center point / CW direction / 3rd axis feed) F: Spiral (Center point / CCW direction / 3rd axis feed) L: Spiral (Pass point / 1st axis feed) M: Spiral (Pass point / 2nd axis feed) N: Spiral (Pass point / 3rd axis feed)
1st axis (L) Movement amount	0	Input the movement amount (position command value). The auxiliary point is input for the spiral interpolation.  The axis numbers allocated to interpolation groups are displayed in (L), (m) and (n) in the ascending order from the smaller number.
1st axis (L) Auxiliary point	0	
2nd axis (m) Movement amount	0	
2nd axis (m) Auxiliary point	0	
3rd axis (n) Movement amount	0	
3rd axis (n) Auxiliary point	0	

### 5.3.2 Operation Patterns and Tables

- Use a number of tables if the positioning patterns consist of P-point control (pass point control), C-point control (continuance point control), and J-point control (speed point control).
- In these types of control, the tables are created continuously on CMI, and "E-point control" is selected for the operation pattern for the last table.
- Start requests are made by specifying the starting data table numbers for each control in user programs.

**Example) When performing three-speed positioning control by P-point control (pass point control)**

Create three positioning tables, and select "E: End point" for the last table. Also, start requests are made by specifying the starting table numbers in user programs.

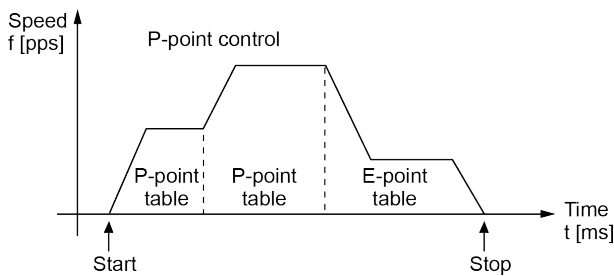

Table No.	Operation pattern	Control method	1st axis (1) Movement amount	Acceleration/deceleration type
1	E: End point	I: Increment	50000	L: Linear
2	E: End point	I: Increment	100000	L: Linear
3	E: End point	I: Increment	30000	L: Linear



#### ◆ REFERENCE

- For details of each control, refer to "8 Automatic Operation (Position Control)".

## 5.4 Synchronous Parameter and Cam Pattern Settings

### 5.4.1 Synchronous Parameter Settings

Parameters required for the synchronous control are assigned using CMI. The following procedure is explained on the condition that CMI has already started. The synchronous parameter setting is made for slave axes.



#### ◆ PROCEDURE

1. Select and double-click the axis for setting the parameters from the project tree.

The synchronous parameter dialog box is displayed.

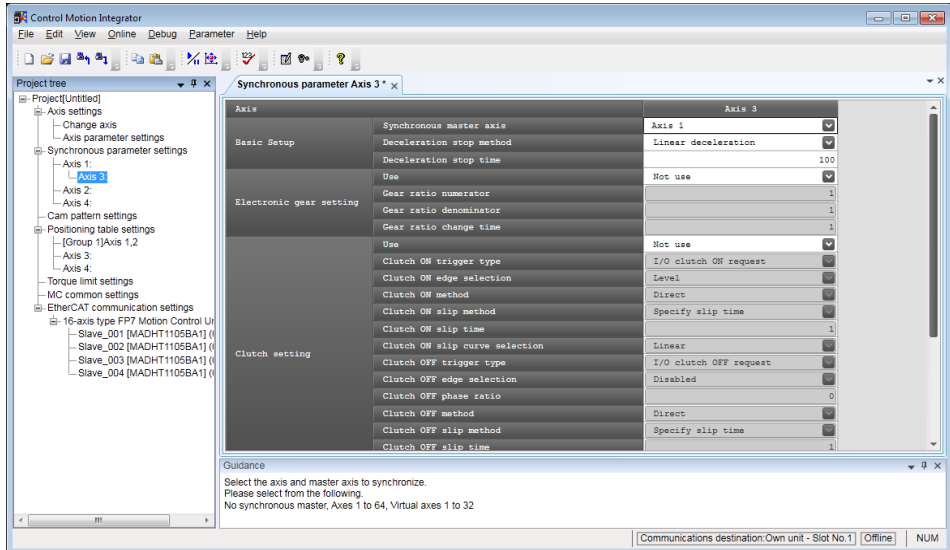

2. Set necessary parameters in accordance with the intended use.



#### ◆ REFERENCE

- For details of the methods of setting parameters related to synchronous control, refer to "9 Automatic Operation (Synchronous Control)".

## 5.4.2 Cam Pattern Setting

Make electronic cam settings in the case of using an electronic cam. Necessary parameters are assigned using CMI. The following procedure is explained on the condition that CMI has already started. The cam pattern setting is made for the cam pattern operation for slave axes.



### ◆ PROCEDURE

1. Select "Parameter" > "Cam pattern settings" from the menu bar.

The cam pattern settings dialog box is displayed.

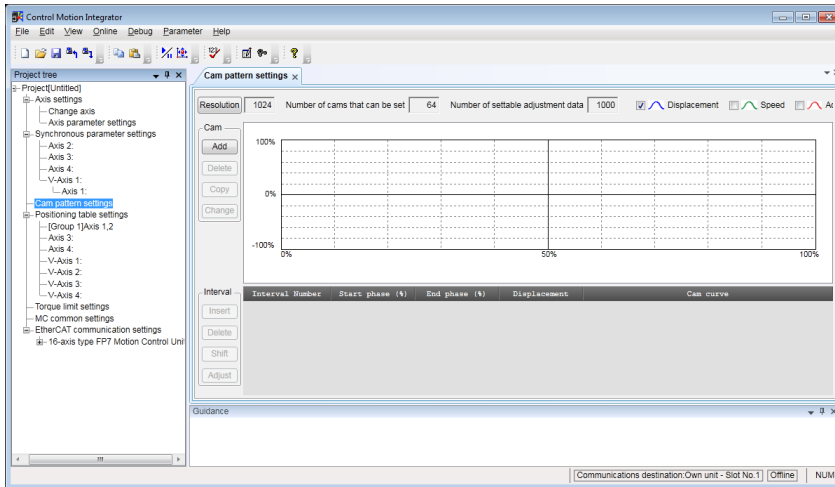

2. Set necessary parameters in accordance with the intended use.



### ◆ KEY POINTS

- The saved parameter information can be read on CMI.
- In the case of synchronous control, it also operates according to the parameters specified in "5.2 Axis Parameter Settings".

## 5.5 Confirmation of Setting Contents

### 5.5.1 Check on Parameter Data

The following procedure is explained on the condition that CMI has already started.



#### ◆ PROCEDURE

1. Select "Debug" > "Check parameters and data values" from the menu bar.

A message box is displayed to show the check result.

(In normal state)

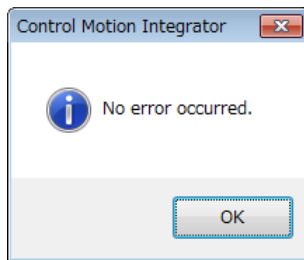

(In abnormal state)

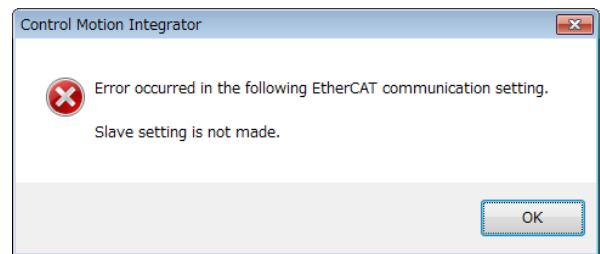

2. Press the [OK] button.

The screen returns to the editing screen of CMI.

## 5.5.2 Comparison of Parameter Information

The following items can be verified using CMI.

- Verifying the data being edited with saved cmi files
- Verifying the data being edited with the unit memory (RAM) data in FP7 MC Unit

The following procedure is explained on the condition that CMI has already started.



### ◆ PROCEDURE

1. **Select "Debug" > "Verify" > "File" or "Unit" from the menu bar.**

When "File" is selected, the "Select verification file" dialog box is displayed.

When "Unit" is selected, the "Verify - Unit" dialog box is displayed.

2. **Select a target (file or unit) to be verified, and press the [OK] button.**

The verification result is displayed.

(In normal state)

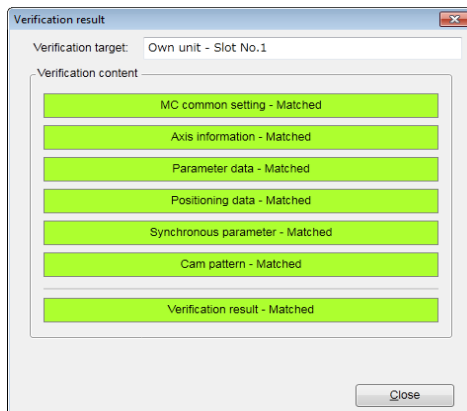

(In abnormal state)

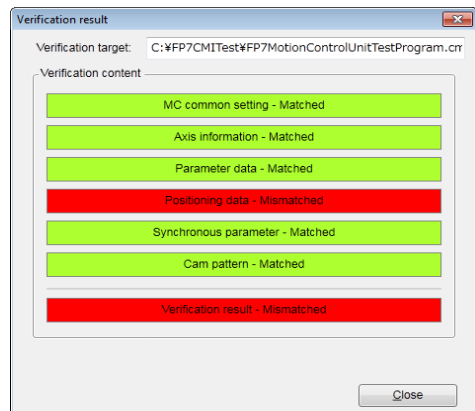

3. **Press the [Close] button.**

The screen returns to the editing screen of CMI.



### ◆ KEY POINTS

- When selecting "Unit" for the verification target, the contents of the unit memories (RAM) in FP7 MC Unit are verified. The contents of the FROM in FP7 MC Unit may not match the contents of the unit memories (RAM).

## 5.6 Transfer of Parameters

### 5.6.1 Writing Parameters to Unit

The set parameter information is downloaded to the memory of FP7 MC Unit. The following procedure is explained on the condition that CMI has already started.



#### ◆ PROCEDURE

1. Select "File" > "Download to Unit" from the menu bar.

A confirmation message is displayed.

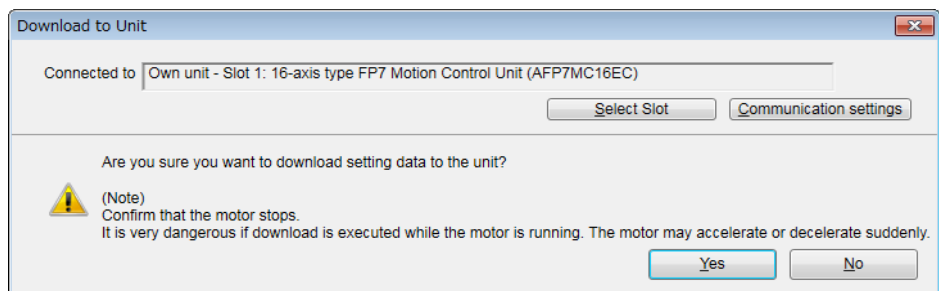

2. Confirm the message, and press the [Yes] button.

When the CPU is in RUN mode, the following message is displayed.

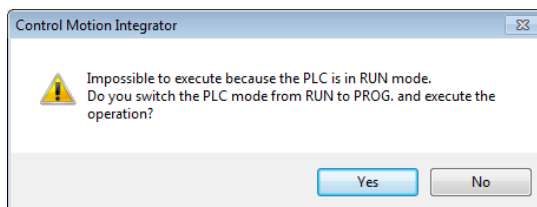

3. Select a unit to which the setting data is downloaded, and press the [Yes] button.

The FROM confirmation message is displayed.

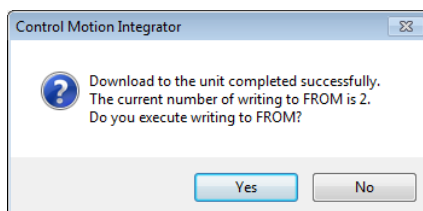

4. Press the [Yes] button to write data to the FROM in FP7 MC Unit, and press the [No] button not to perform the writing.

When the processing is finished, the following message is displayed.

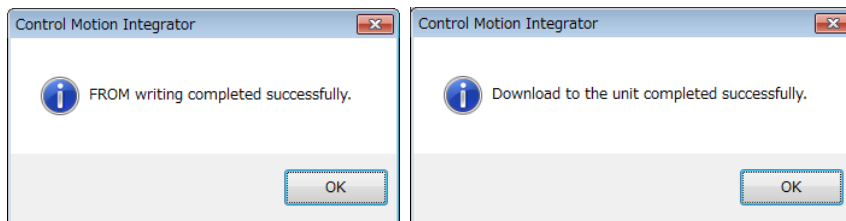

5. Press the [OK] button.

The message for confirming the mode switching of the CPU unit is displayed.

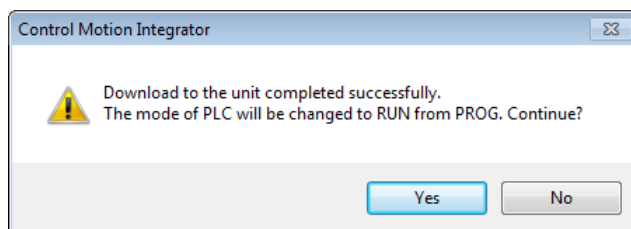

6. Press the [Yes] or [No] button.



#### ◆ KEY POINTS

---

- Executing "Writing to FROM" writes set parameters to the FROM in FP7 MC Unit. When the power turns on again, the parameters are read into the unit memory (RAM) from the FROM.
- When "Write to FROM" is not executed, the set parameters are temporarily written to the unit memories (RAM) in FP7 MC Unit and used as data during operations. However, when the power turns on again, they are overwritten by the parameters written into the FROM.
- It is also possible to execute "Online" > "Write to FROM" on CMI.
- "Write to FROM" can also be executed by turning on the FROM write request (Y3) of user programs. However, we recommend using differential execution with this instruction to prevent the writing from being executed continuously.



#### ◆ NOTES

---

- Writing to FROM can be performed up to 10000 times. Do not write data to FROM more than 10000 times.



# 6

## Data Transfer to MC Unit and Test Operation

## 6.1 Before Turning On the Power

### System configuration example

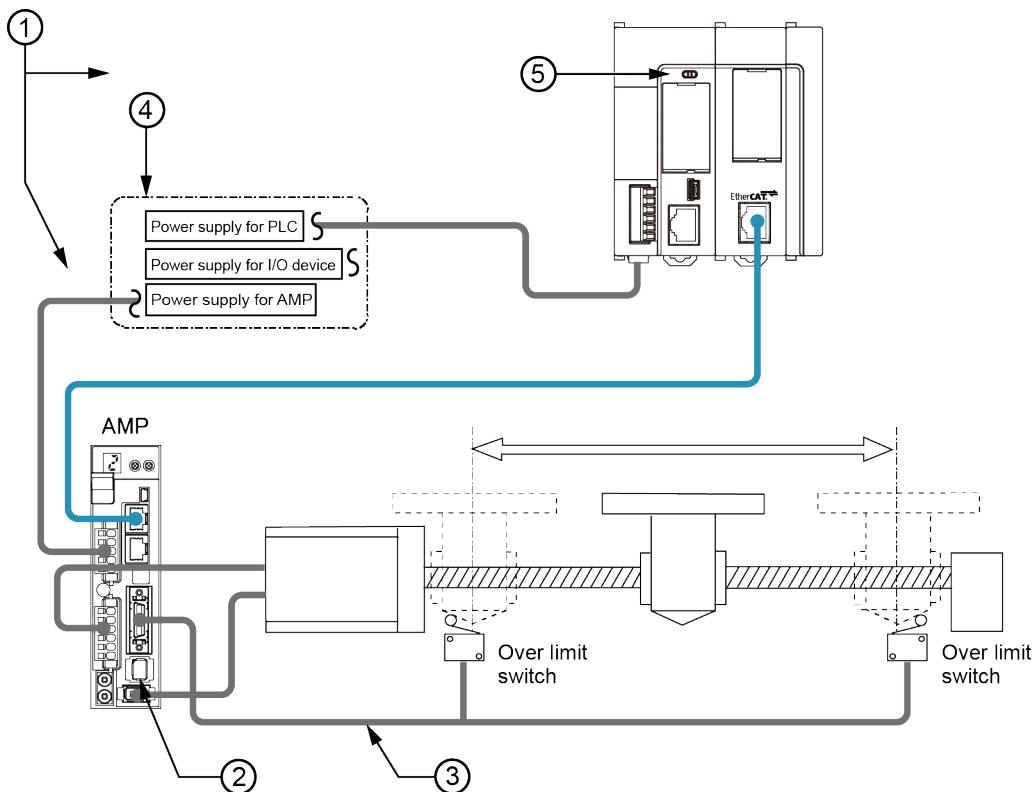

#### ■ Items to check before turning on the power

No.	Item	Description
①	Checking connections to the various devices	Check to make sure the various devices have been connected as indicated by the design.
②	Checking the servo amplifier	Check the wiring of servo amplifier and parameter settings.
③	Checking the installation of the safety circuit	Check the connection between the servo amplifier and over limit switches. Check the installation condition of the over limit switches. Check if the limit input can be monitored on PLC.
④	Checking the procedure settings for turning on the power supplies	Check to make sure settings have been entered so that power supplies are turned on according to the procedure outlined in the section "Procedure for Turning On the Power" on the next page.
⑤	Setting configuration data	Check if the parameters and positioning data are configured in FP7 MC Unit as designed.
	Checking the CPU mode selection switch	Set the CPU unit to PROG. mode. Setting it in RUN mode can cause inadvertent operation.
	Checking user programs	Create programs to turn off the start request of each operation when switching the mode to RUN mode. If they are on, they may activate improperly.

## 6.2 Power-on and Power-off Sequences

---

### 6.2.1 Procedure for Turning On the Power

---

When turning on the power to the system incorporating the unit, consider the nature and states of any external devices connected to the system, and take sufficient care so that turning on the power will not initiate unexpected movements.



#### ◆ PROCEDURE

---

---

1. Turn on the power supplies for the input and output devices connected to the PLC.
2. Turn on the power supply for the servo amplifier.
3. Turn on the power supply for the PLC.



#### ◆ REFERENCE

---

---

- If you want to delay the EtherCAT communication start time after the PLC is turned ON, refer to "13.14 How to Delay EtherCAT Communication Startup after Power ON".

### 6.2.2 Procedure for Turning Off the Power

---



#### ◆ PROCEDURE

---

---

1. Check to make sure the rotation of the motor has stopped, and then turns off the power supply for the PLC.
2. Turn off the power supply for the servo amplifier.
3. Turn off the power supplies for the input and output devices connected to the PLC.

## 6.3 Checking While the Power is ON

### 6.3.1 Items to Check When the Power is ON

#### System configuration example

Check each item in the following four major steps.

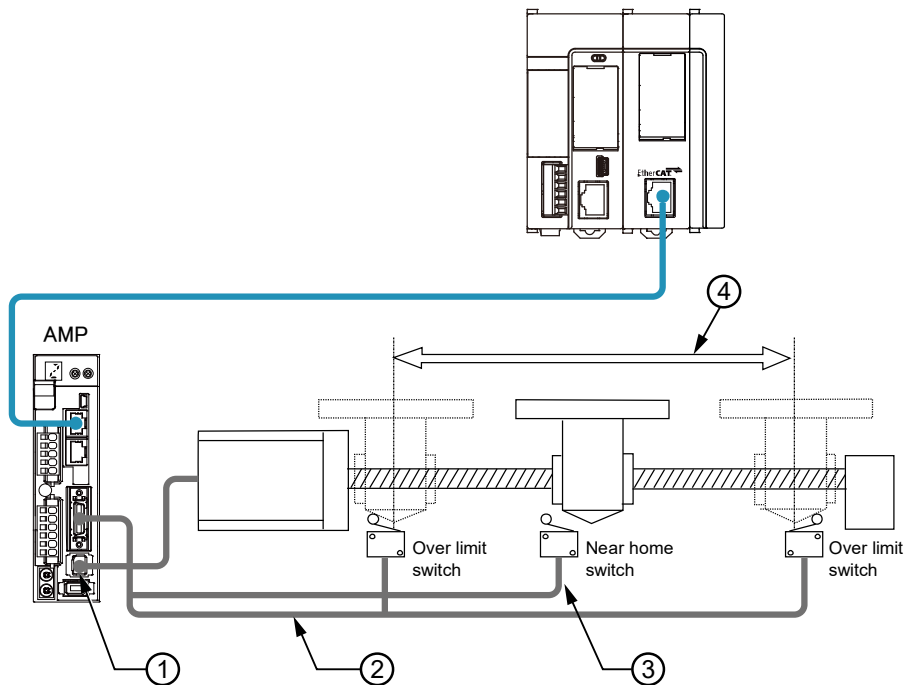

#### ■ Items to check after turning on the power

No.	Item	Description
①	Checking the communication state	Check if the communication between FP7 MC Unit and Servo Amplifier is performed properly.
②	Checking the safety circuit by the PLC unit	Check the connection between the servo amplifier and over limit switches. Check the installation condition of the over limit switches. Check if the over limit switch is loaded as the limit input of FP7 MC Unit and activated properly by performing JOG operation.
③	Checking the near home input	Check the connection between the servo amplifier and near home input. Check the installation condition of the near home input. Check if the near home input is loaded as the near home input of FP7 MC Unit and activated properly by performing JOG operation or home return operation.
④	Checking the rotation, moving direction, and moving distance.	Check the rotation, moving direction and moving distance by performing JOG operation or positioning operation.

## 6.3.2 Checking Network Communication State

---

### Procedure 1

Turn on the powers of the servo amplifier and FP7 MC Unit in this order, and check if no error occurs.

### Procedure 2

If an error occurs, check if the settings agree with the actual network configuration on CMI.

### Points to check

After turning on FP7 MC Unit, the time until slaves participate in the network can be confirmed and changed in the axis parameter setting menu of CMI.

### 6.3.3 Checking the Safety Circuit by the PLC Unit

---

#### Procedure 1

Check if the input of the over limit switches connected to the servo amplifier is loaded to FP7 MC Unit by operating them forcibly.

#### Points to check

Check if the limit setting is enabled, input logic is correct in the parameter setting menu of CMI.

#### Procedure 2

Check if the limit stop is activated at the time of limit input by the tool operation function of CMI or performing the JOG operation with a program.

#### Procedure 3

Using the JOG operation, check if the over limit switch is functioning properly.

#### ■ Operation at Over limit input (Limit is Enabled)

Condition	Direction	Limit status	Operation
When JOG operation is started	Forward	Over limit input (+): ON	Not executable, Error occurs.
		Over limit input (-): ON	Executable
	Reverse	Over limit input (+): ON	Executable
		Over limit input (-): ON	Not executable, Error occurs.
During JOG operation	Forward	Over limit input (+): ON	Limit stops, Error occurs.
	Reverse	Over limit input (-): ON	Limit stops, Error occurs.

### 6.3.4 Checking the Operation of Near Home Input

---

#### Procedure 1

Check if the near home input is loaded as an input signal on the PLC properly by operating the input forcibly.

#### Procedure 2

Start the home return by the tool operation function of CMI or inputting the home return program, and check if the operation transits to the deceleration operation by the near home input.

#### Points to check

The logic of near home input depends on the settings of Servo Amplifier and FP7 MC Unit.

#### Procedure 3

Check if the home stop position shifts by repeating the JOG and home return operations.

#### Procedure 4

If the home stopping position is shifted, change the position of near home input or reduce the home return speed.

### 6.3.5 Checking Rotating and Moving Directions and Moving Distance

---

#### Procedure 1

Execute the JOG operation to confirm the rotating direction and moving direction of the motor. Use the tool operation function of CMI and perform the JOG operation.

#### Points to check

The rotating direction is determined according to the installation of the ball screw or the "CW/CCW direction setting" of the axis parameter.

#### Procedure 2

Check if the moving distance is that as designed by performing the JOG operation or positioning operation.

#### Points to check

The moving distance is determined according to the pitch of the ball screw, deceleration gear ratio or setting movement amount of the positioning data.

## 6.4 Monitor Function of CMI

### 6.4.1 Status Monitor

- The connection state of each axis and input state of external terminals can be monitored.
- The following procedure is explained on the condition that CMI has already started.



#### ◆ PROCEDURE

1. Select "Online" > "Status Monitor" from the menu bar.

The status monitor dialog box is displayed.

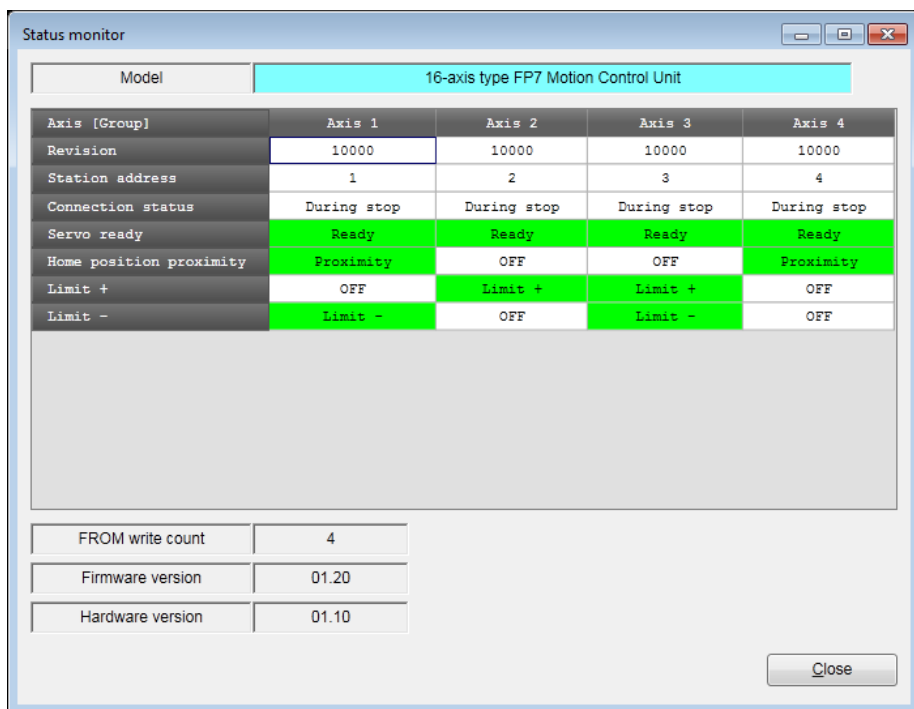



### ■ Monitoring item

Item	Description
Revision	Indicates the revision number of Servo Amplifier A6B/A5B.
Station address	Indicates the station address of Servo Amplifier A6B/A5B allocated to each axis.
Connection status	Indicates the connection status of each axis. Not connected / During stop / During operation / Warning occurs / Error occurs
Servo ready	Indicates the servo ready status on the servo amplifier side. Ready (Green): Indicates that the servo is ready. Off (White): Indicates the servo is off.
Home position proximity	Indicates the status of the near home input (HOME). Near home (Green): Indicates the input is valid. Off (White): Indicates the input is invalid.
Limit +	Indicates the status of the limit input. Monitored signals vary according to the settings of "Axis parameter settings" of FP7 MC Unit. Limit + (Green) or limit - (Green): Indicates the input is enabled. Off (White): Indicates the input is disabled.
Limit -	
FROM write count	Indicates the number of times of writing to FROM in FP7 MC Unit. Writing can be performed up to 10000 times.
Firmware version	Indicates the firmware version of FP7 MC Unit.
Hardware version	Indicates the hardware version of FP7 MC Unit.



### ◆ KEY POINTS

- The input logics of the near home, limit + and limit - depend on the settings of Servo Amplifier A6B/A5B and FP7 MC Unit.
- The target limit inputs to be monitored vary according to the settings of axis parameters as below. Confirm them with CMI.

Parameter name	Selection	Description
Axis parameters - Basic setup - Limit switch	N: Disabled	Indicates the POT/NOT status of Servo Amplifier A6B/A5B. Limit +: POT (CW over-travel inhibit input) Limit -: NOT (CCW over-travel inhibit input)
	A: Enabled	Indicates the SI-MON3/SI-MON4 status of Servo Amplifier A6B/A5B. Limit +: SI-MON3 (General-purpose monitor input 3) Limit -: SI-MON4 (General-purpose monitor input 4)

## 6.4.2 Data Monitor

The operating state can be monitored.



### ◆ PROCEDURE

1. Select "Online" > "Data Monitor" from the menu bar.

The data monitor dialog box is displayed.

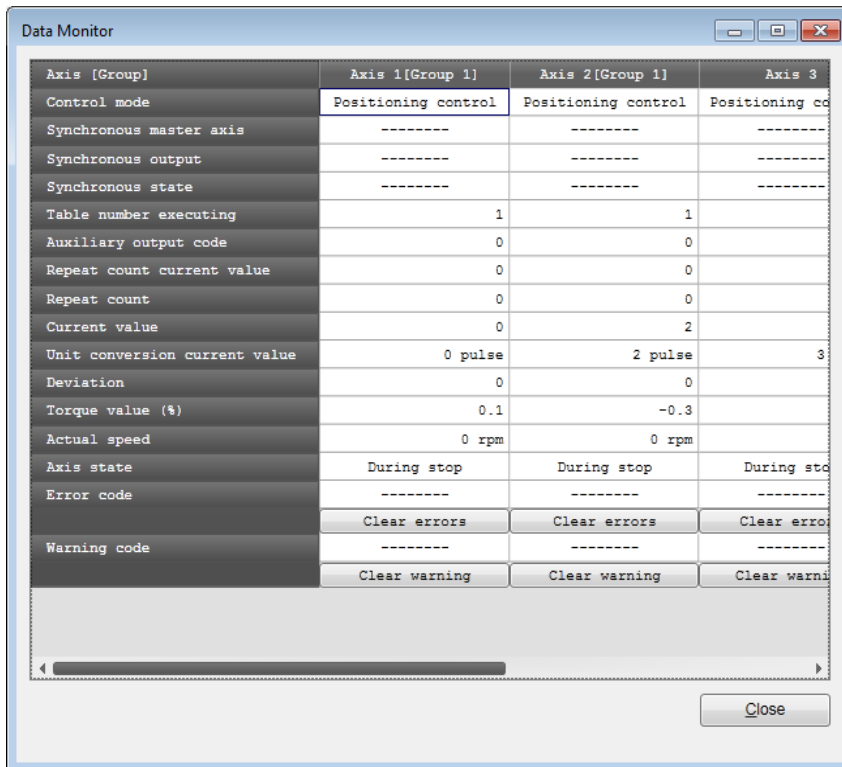

### ◆ KEY POINTS

- If a recoverable error occurs in FP7 MC Unit, click the [Clear errors] button to clear the error.
- If a warning occurs in FP7 MC Unit, click [Clear warning] to clear the warning of FP7 MC Unit.
- The difference between the value of the position specified in FP7 MC Unit and the value of the position fed back from Servo Amplifier A6B/A5B is calculated on the FP7 MC Unit side as a deviation. This value is not the same as the value of the deviation counter of the servo amplifier.

### ■ Monitoring item

Item	Description	Related page
Control mode	Displays the control mode. Positioning control / J-point control / Home return / JOG operation	
Synchronous master axis	When an axis has been set as master axis, "Master" is displayed. When an axis has been set as slave axis, the master axis which this axis follows is displayed. Example) When the second axis has been set as a slave axis for the master of first axis, "1 axis" is displayed in the column of 2 axes. For axes that are not used for the synchronous control, "-----" is displayed.	9.2 Settings for Master and Slave Axes
Synchronous output	Displays the functions of synchronous operation that have been set for slave axes. Gear, Clutch, Cam Gear+Clutch, Gear+Cam, Clutch+Cam Gear+Clutch+Cam For axes that are not used for the master axes and synchronous control, "--- ----" is displayed.	9.1 Synchronous Control
Synchronous state	Displays the states (synchronous/asynchronous) that have been set for each axis.	
Table number executing	Displays the table number that the positioning data is being executed or has been executed.	
Auxiliary output code	When the auxiliary output function is enabled, output code is output within the range of 0 to 65535.	8.7 Auxiliary Output Code and Auxiliary Output Contact
Repeat count current value	Displays the current value of the repeat count.	8.3 Repeat Function
Repeat count	When setting to repeat operations, the repeat count is displayed (0 to 255). When this function is not set, the repeat count is "0".	
Current value (pulse)	Displays the current value of FP7 MC Unit. It will return to "0" on the completion of home return.	13.2 Current Value Update 13.3 Home Coordinates
Unit conversion current value	Displays the unit-converted current value of FP7 MC Unit. It will return to "0" on the completion of home return. When the home coordinate has been set, it will be preset to the home coordinate on the completion of home return.	
Deviation	The difference value between the value of the position specified in FP7 MC Unit and the value of the position fed back from the amplifier is stored. In the case of virtual axes, "-----" is displayed.	
Torque value (%)	Displays the current value of the torque value.	13.6.1 Torque Judgement
Actual speed (rpm)	Displays the current value of the actual speed.	13.6.2 Actual Speed Judgement
Axis state	Displays "During operation" or "During stop". Displays "Error occurs" when an error occurs.	
Error code	Displays the latest error code when an error has occurred. Pressing the "Clear errors" button clears errors.	
Warning code	Displays the latest warning code when a warning has occurred. Pressing the "Clear warning" button clears warnings of FP7 MC Unit.	

## 6.5 Tool Operation Function of CMI

---

### 6.5.1 Tool Operation Function

---

You can perform commissioning with CMI before actually starting user programs. The following procedure is explained on the condition that CMI has already started.



#### ◆ PROCEDURE

---

1. Select "Online" > "Tool Operation" from the menu bar.

A confirmation message is displayed.

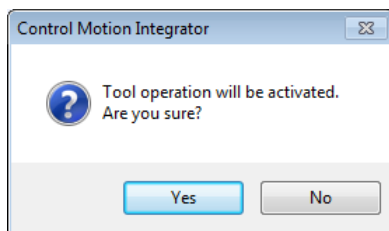

2. Press the [Yes] button.

The "Tool operation" dialog box is displayed.

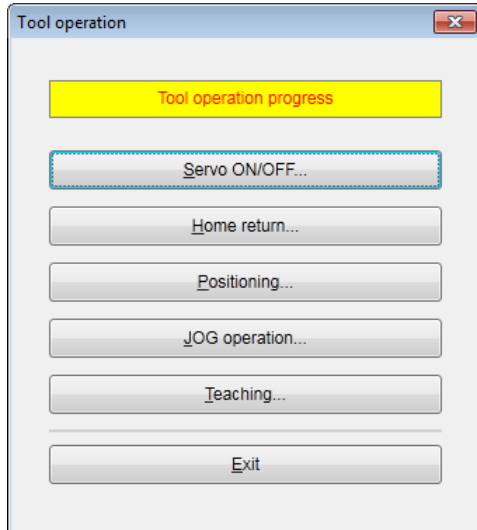

### ■ Type of tool operation

Item	Description
Servo ON/OFF	Specify the servo ON/OFF setting for each axis.
Home Return	A home return is performed to the home of the machine coordinates according to the specified parameter.
Positioning	Moves from the start table number according to the set contents of the positioning table.
JOG Operation	The specified axis can be moved to the specified direction at the specified speed while the operation command is on.
Teaching	Controls the axis like JOG operation, and reflects the resulting positioning address on the data editing screen.



### ◆ KEY POINTS

- The unit cannot go into the tool operation while the unit is operated with a user program.
- Operation requests using unit memories (output control area) are disabled during the tool operation.
- If any communication error occurs during the tool operation, FP7 MC Unit will detect the error and stop automatically. Also, if the previous tool operation does not finish properly due to any error such as communication error, the tool operation mode will be canceled forcibly when the next tool operation starts. Exit the operation once, and start the tool operation again.

## 6.5.2 Serve ON/OFF with Tool Operation Function

The following procedure is explained on the condition that CMI has already started.



### ◆ PROCEDURE

1. Select "Online" > "Tool Operation" from the menu bar.

The "Tool operation" dialog box is displayed.

2. Select "Servo ON/OFF" in the "Tool operation" dialog box.

The "Servo ON/OFF" dialog box is displayed.

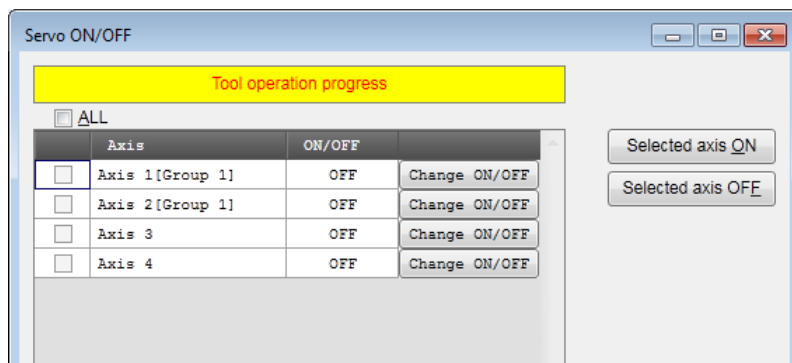

3. Select a desired axis, and press the [Change ON/OFF] button.

The state is switched between servo lock and servo free.

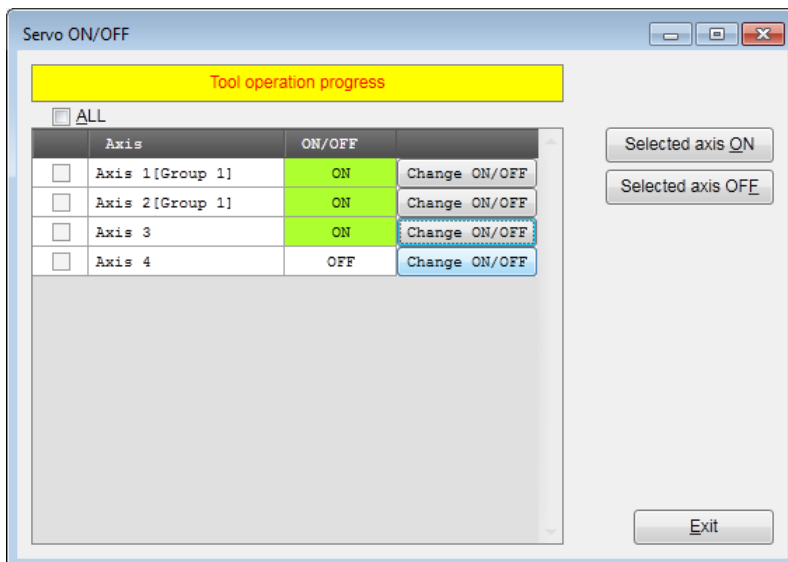

4. Confirm the servo ON/OFF states of arbitrary axes, and press the "Exit" button.

This returns to the "Tool operation" dialog box.



---

◆ **KEY POINTS**

---

- If the servo ON/OFF has been controlled using user programs, the servo-lock or servo-free state before the start of the tool operation is kept and the operation shifts to the tool operation.
- The servo-lock or servo-free state before the completion will be kept even after finishing the tool operation mode.

### 6.5.3 JOG Operation with Tool Operation Function

- You can perform commissioning with CMI before actually starting user programs.
- The following procedure is explained on the condition that CMI has already started.



#### ◆ PROCEDURE

1. Select "Online" > "Tool Operation" from the menu bar.  
The "Tool operation" dialog box is displayed.
2. Select "JOG operation" from the tool operation dialog box.  
The "Tool operation - JOG operation" dialog box is displayed.

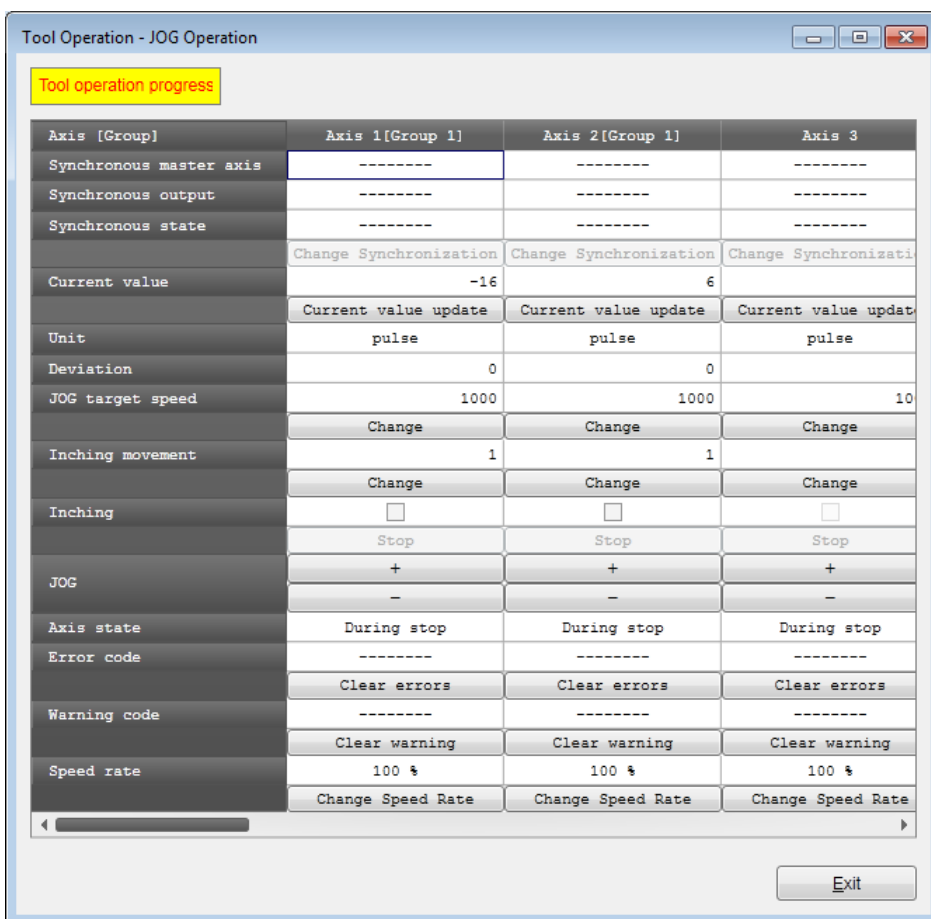

3. Press [+] or [-] button in the JOG field.  
The JOG operation is executed.
4. Press [Exit] button to terminate the JOG operation.





## ◆ KEY POINTS

- If a recoverable error occurs in FP7 MC Unit, click the [Clear errors] button to clear the error.
- If a warning occurs in FP7 MC Unit, click [Clear warning] to clear the warning of FP7 MC Unit.

### ■ Items of dialog box

Item	Description	Related page
Synchronous master axis	When an axis has been set as master axis, "Master" is displayed. When an axis has been set as slave axis, the master axis which this axis follows is displayed. Example) When the second axis has been set as a slave axis for the master of first axis, "1 axis" is displayed in the column of 2 axes. For axes that are not used for the synchronous control, [- - - - -] is displayed.	9.2 Settings for Master and Slave Axes
Synchronous output	The functions of synchronous operation that have been set for slave axes are displayed. Gear, Clutch, Cam Gear+Clutch, Gear+Cam, Clutch+Cam Gear+Clutch+Cam For axes that are not used for the master axes and synchronous control, [- - - - -] is displayed.	9.1 Synchronous Control
Synchronous state	The states (synchronous/asynchronous) that have been set for each axis are displayed. Pressing the "Change synchronization" button switches the state between Synchronous and Asynchronous.	
Current value	Displays the current value after the unit system conversion. Click [Current value update] to display the dialog for inputting value to change the preset value.	13.2 Current Value Update
Unit	The units of the position command value and speed command value are displayed for each axis.	
Deviation (pulse)	The difference value between the value of the position specified in FP7 MC Unit and the value of the position fed back from the amplifier is stored. For virtual axes, [- - - - -] is always displayed.	
JOG target speed	Monitors and displays the target speed in the JOG operation. Click [Change] to change the target speed for the JOG operation.	10.1 Settings and Operations of JOG Operation 10.3 Setting and Operation of JOG Inching Operation
Inching movement	The inching movement amount is set.	
Inching	Check the box for performing the inching operation.	
JOG [+]	Click [+] to perform the forward rotation of the JOG operation.	
JOG [-]	Click [-] to perform the reverse rotation of the JOG operation.	
Axis state	Displays "During operation" or "During stop". Displays "Error occurs" when an error occurs. Displays "Warning occurs" when a warning occurs.	
Error code	Displays the latest error code when an error has occurred. Pressing the "Clear errors" button clears errors.	
Warning code	Displays the latest warning code when a warning has occurred. Pressing the "Clear warning" button clears warnings of FP7 MC Unit.	
Speed rate	The target speed of the JOG operation set in the parameter settings for each axis is regarded as 100%, and the operation is executed in the specified speed rate. Clicking [Change Speed Rate] shows the dialog for inputting the value.	

## 6.5.4 Home Return by Tool Operation Function

- When the power is turned on, the coordinates of FP7 MC Unit do not coincide with those of the machine position. Execute a home return before starting positioning.
- You can perform commissioning with CMI before actually starting user programs.
- The following procedure is explained on the condition that CMI has already started.



### ◆ PROCEDURE

1. Select "Online" > "Tool Operation" from the menu bar.

The "Tool operation" dialog box is displayed.

2. Select "Home Return" from the tool operation dialog box.

The "Tool operation - Home return" dialog box is displayed.

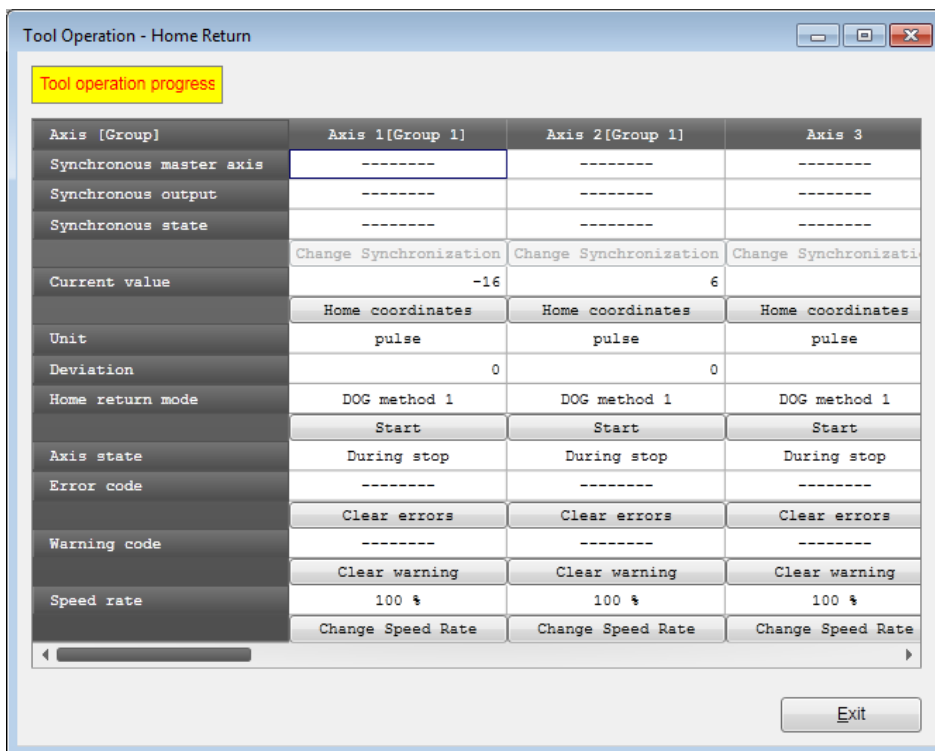

3. Click [Start] for the axis to execute the home return.

Execute the home return operation.

4. Press [Exit] button to terminate the home return operation.



## ◆ KEY POINTS

- If a recoverable error occurs in FP7 MC Unit, click the [Clear errors] button to clear the error.
- If a warning occurs in FP7 MC Unit, click [Clear warning] to clear the warning of FP7 MC Unit.
- This dialog box cannot be closed during the operation.

### ■ Items of dialog box

Item	Description	Related page
Synchronous master axis	When an axis has been set as master axis, "Master" is displayed. When an axis has been set as slave axis, the master axis which this axis follows is displayed. Example) When the second axis has been set as a slave axis for the master of first axis, "Axis 1" is displayed in the column of Axis 2. For axes that are not used for the synchronous control, [- - - - -] is displayed.	9.2 Settings for Master and Slave Axes
Synchronous output	The functions of synchronous operation that have been set for slave axes are displayed. Gear, Clutch, Cam Gear+Clutch, Gear+Cam, Clutch+Cam Gear+Clutch+Cam For axes that are not used for the master axes and synchronous control, [- - - - -] is displayed.	9.1 Synchronous Control
Synchronous state	The states (synchronous/asynchronous) that have been set for each axis are displayed. Pressing the "Change synchronization" button switches the state between Synchronous and Asynchronous.	
Current value	Displays the current value after the unit system conversion. Click [Home position coordinate] to display the dialog box for inputting value to change the value after home return.	13.3 Home Coordinates
Unit	The units of the position command value and speed command value are displayed for each axis.	
Deviation (pulse)	The difference value between the value of the position specified in FP7 MC Unit and the value of the position fed back from the amplifier is stored. For virtual axes, [- - - - -] is always displayed.	
Home return mode	Displays the content of the home return setting code registered in the positioning setting data.	
Start/Stop	Executes the operation to start/stop the home return. - Click [Start] to execute the home return operation. The button name changes to [Stop]. - Click [Stop] to execute the deceleration stop operation. The button name changes to [Start].	
Axis state	Displays "During operation" or "During stop". Displays "Error occurs" when an error occurs. Displays "Warning occurs" when a warning occurs.	
Error code	Displays the latest error code when an error has occurred. Pressing the "Clear errors" button clears errors.	
Warning code	Displays the latest warning code when a warning has occurred. Pressing the "Clear warning" button clears warnings of FP7 MC Unit.	
Speed rate	The target speed of the home return set in the parameter settings for each axis is regarded as 100%, and the operation is executed in the specified speed rate. Clicking [Change Speed Rate] shows the dialog for inputting the value.	

## 6.5.5 Positioning by Tool Operation Function

Specifying a starting table number enables to check if positioning from the starting table operates properly.



### ◆ PROCEDURE

1. Select "Online" > "Tool Operation" from the menu bar.

The "Tool operation" dialog box is displayed.

2. Select "Positioning" from the tool operation dialog box.

The "Tool operation - Positioning" dialog box is displayed.

Axis [Group]	Axis 1[Group 1]	Axis 2[Group 1]	Axis 3
Synchronous master axis	-----	-----	-----
Synchronous output	-----	-----	-----
Synchronous state	-----	-----	-----
	Change Synchronization	Change Synchronization	Change Synchroniz
Repeat count current value	0	0	
Repeat count	0	0	
	Change	Change	Change
Current value	-16	5	
	Current value update	Current value update	Current value up
Unit	pulse	pulse	pulse
Deviation	0	1	
Table number executing	1	1	
Start table number	1	1	
	Change	Change	Change
	Operate	Operate	Operate
Axis state	During stop	During stop	During stop
Error code	-----	-----	-----
	Clear errors	Clear errors	Clear errors
Warning code	-----	-----	-----
	Clear warning	Clear warning	Clear warning
Speed rate	100 %	100 %	100 %
	Change Speed Rate	Change Speed Rate	Change Speed Re

3. Press the [Change] button under the target start table number field.

The starting table no. setting dialog box is displayed.

4. Input a starting table number.

5. Press the [Operate] button.

Positioning starts from the specified start table number.

6. Press [Exit] button to terminate the positioning operation.

### ■ Items of dialog box

Item	Description	Related page
Synchronous master axis	When an axis has been set as master axis, "Master" is displayed. When an axis has been set as slave axis, the master axis which this axis follows is displayed. Example) When the second axis has been set as a slave axis for the master of first axis, "Axis 1" is displayed in the column of Axis 2. For axes that are not used for the synchronous control, [- - - - -] is displayed.	9.2 Settings for Master and Slave Axes
Synchronous output	The functions of synchronous operation that have been set for slave axes are displayed. Gear, Clutch, Cam Gear+Clutch, Gear+Cam, Clutch+Cam Gear+Clutch+Cam For axes that are not used for the master axes and synchronous control, [- - - - -] is displayed.	9.1 Synchronous Control
Synchronous state	The states (synchronous/asynchronous) that have been set for each axis are displayed. Pressing the "Change synchronization" button switches the state between Synchronous and Asynchronous.	
Repeat count current value	Displays the current value of the repeat count.	8.3 Repeat Function
Repeat count	Displays the setting value of the repeat count.	
Current value	Displays the current value after the unit system conversion. Click [Current value update] to display the dialog for inputting value to update the current value.	13.2 Current Value Update
Unit	The units of the position command value and speed command value are displayed for each axis.	
Deviation (pulse)	The difference value between the value of the position specified in FP7 MC Unit and the value of the position fed back from the amplifier is stored. For virtual axes, [- - - - -] is always displayed.	
Table number executing	Displays the table number during the operation or when it completes.	
Start table number	The starting table number for the positioning control. Click [Change] to change the starting table number.	
Operate/Stop	Execute the operation to start/stop the home return. - Click [Operate] to execute the positioning operation. The button name changes to [Stop]. - Click [Stop] to execute the deceleration stop operation. The button name changes to [Operate].	
Axis state	Displays "During operation" or "During stop". Displays "Error occurs" when an error occurs. Displays "Warning occurs" when a warning occurs.	
Error code	Displays the latest error code when an error has occurred. Pressing the "Clear errors" button clears errors.	
Warning code	Displays the latest warning code when a warning has occurred. Pressing the "Clear warning" button clears warnings of FP7 MC Unit.	
Speed rate	The target speed set in the parameter settings for each axis is regarded as 100 %, and the operation is executed in the specified speed rate. Clicking [Change Speed Rate] shows the dialog for inputting the value.	



## ◆ KEY POINTS

---

- Even in the tool operation, the unit operates in accordance with the data of the positioning table downloaded to FP7 MC Unit. The operations after the starting table number vary depending on operation patterns.
- If a recoverable error occurs in FP7 MC Unit, click the [Clear errors] button to clear the error.
- If a warning occurs in FP7 MC Unit, click [Clear warning] to clear the warning of FP7 MC Unit.
- The positioning operation of an interpolation group starts and stops the axis with the smallest number in the group. In the case of the tool operation function, the "Operate" buttons other than that for the smallest axis number cannot be pressed
- This dialog box cannot be closed during the operation.
- When conditions are changed during the tool operation, the operation continues by updating the unit memories temporarily, however, the changes are not reflected in the configuration data written in the FROM within FP7 MC Unit. Therefore, when the power is turned on again, the unit is booted based on the configuration data written in the FROM within FP7 MC Unit.

## 6.5.6 Teaching by Tool Operation Function

Activate each axis manually by the tool operation, and register the positioning addresses where each axis stops as the point data.



### ◆ PROCEDURE

1. Select "Online" > "Tool Operation" from the menu bar.

The "Tool Operation" dialog box is displayed.

2. Select "Teaching" from the tool operation dialog box.

The "Tool Operation - Teaching" dialog box is displayed.

Axis [Group]	Axis 1[Group 1]	Axis 2[Group 1]	Axis 3
Synchronous master axis	-----	-----	-----
Synchronous output	-----	-----	-----
Synchronous state	-----	-----	-----
Current value	Change Synchronization -16	Change Synchronization 5	Change Synchronizati -----
Unit	Current value update pulse	Current value update pulse	Current value updat pulse
Deviation	0	1	-----
JOG target speed	1000	1000	10
Inching movement	Change 1	Change 1	Change -----
Inching	Change <input type="checkbox"/>	Change <input type="checkbox"/>	Change <input type="checkbox"/>
JOG	Stop +	Stop +	Stop +
Table number	- 1	- 1	- -----
Axis state	Teaching During stop	Teaching During stop	Teaching During stop
Error code	----- Clear errors	----- Clear errors	----- Clear errors
Warning code	----- Clear warning	----- Clear warning	----- Clear warning
Speed rate	100 % Change Speed Rate	100 % Change Speed Rate	100 % Change Speed Rate

3. Stop at the positioning point by the JOG operation.
4. Press the [Teaching] button.
5. Input the table number where the desired positioning information is registered, and click the [OK] button.

The current value is registered for the amount of movement of the table number specified. Also, if the axis that the teaching operation is performed is an interpolation axis, the current value is registered for the movement amount of the equivalent coordinate in the interpolation group.

6. Press [Exit] button to terminate the teaching operation.

■ Items of dialog box

Item	Description	Related page
Synchronous master axis	When an axis has been set as master axis, "Master" is displayed. When an axis has been set as slave axis, the master axis which this axis follows is displayed. Example) When the second axis has been set as a slave axis for the master of first axis, "Axis 1" is displayed in the column of Axis 2. For axes that are not used for the synchronous control, [- - - -] is displayed.	9.2 Settings for Master and Slave Axes
Synchronous output	The functions of synchronous operation that have been set for slave axes are displayed. Gear, Clutch, Cam Gear+Clutch, Gear+Cam, Clutch+Cam Gear+Clutch+Cam For axes that are not used for the master axes and synchronous control, [- - - -] is displayed.	9.1 Synchronous Control
Synchronous state	The states (synchronous/asynchronous) that have been set for each axis are displayed. Pressing the "Change synchronization" button switches the state between Synchronous and Asynchronous.	
Current value	Displays the current value after the unit system conversion. Click [Current value update] to display the dialog for inputting value to change the preset value.	13.2 Current Value Update
Unit	The units of the position command value and speed command value are displayed for each axis.	
Deviation (pulses)	The difference value between the value of the position specified in FP7 MC Unit and the value of the position fed back from the amplifier is stored. For virtual axes, [- - - -] is always displayed.	
JOG target speed	Monitors and displays the target speed in the JOG operation. Click [Change] to change the target speed for the JOG operation.	10.1 Settings and Operations of JOG Operation
Inching movement	The inching movement amount is set.	
Inching	Check the box for performing the inching operation.	10.3 Setting and Operation of JOG Inching Operation
JOG [+]	Click [+] to perform the forward rotation of the JOG operation.	
JOG [-]	Click [-] to perform the reverse rotation of the JOG operation.	
Table number	Displays the table number to perform the teaching. Click [Teaching] to change the table number for the teaching and register the current value.	
Axis state	Displays "During operation" or "During stop". Displays "Error occurs" when an error occurs. Displays "Warning occurs" when a warning occurs.	
Error code	Displays the latest error code when an error has occurred. Pressing the "Clear errors" button clears errors.	
Warning code	Displays the latest warning code when a warning has occurred. Pressing the "Clear warnings" button clears warnings of FP7 MC Unit.	
Speed rate	The target speed of the JOG operation set in the parameter settings for each axis is regarded as 100%, and the operation is executed in the specified speed rate. Clicking [Change Speed Rate] shows the dialog for inputting the value.	





---

◆ **KEY POINTS**

---

- If a recoverable error occurs in FP7 MC Unit, click the [Clear errors] button to clear the error.
- If a warning occurs in FP7 MC Unit, click [Clear warning] to clear the warning of FP7 MC Unit.
- The control method for the table number that the teaching operation was performed is automatically changed to “Absolute”.
- The result of the teaching becomes effective once the tool operation quits and the setting data is downloaded to FP7 MC Unit.
- This dialog box cannot be closed during the operation.



# 7

## Creation of User Programs

## 7.1 How to Create User Programs

### 7.1.1 Basic Configuration of Program

The user programs which control FP7 MC Unit are created by the tool software "FPWIN GR7".

- To support the multi-axis control through network, for FP7 MC Unit, main input and output signals required for the control are allocated to the unit memories (input control area/output control area).
- For various controls, the processes of reading flags from unit memories (input control area) and writing operation results to unit memories (output control area) are created as programs. They are executed to transfer data between units at the time of I/O refresh.
- As exceptions, the "link establishment flag (X0)" for storing the link establishment of network and "system stop request (Y0)" for stopping the whole system are allocated to the area of I/O signals (XY).

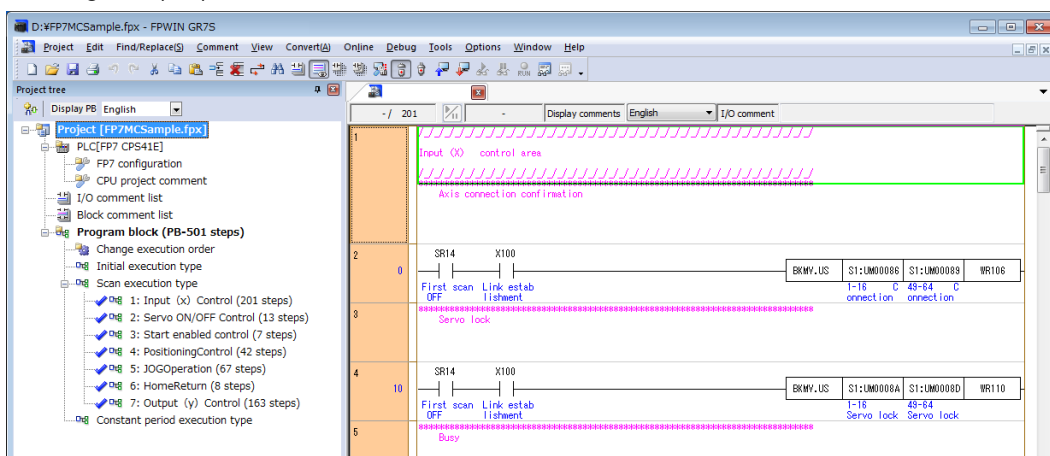

#### ■ Configuration of program

Item	Description
①	Reading from unit memories UM (input control area) Reads information required for confirming states from the unit memories (input control area) to an arbitrary operation memories (such as internal relay area WR). Example) Connection confirmation flag, servo lock flag, busy flag, error annunciation flag
②	Servo control Outputs the requests for the servo on and servo off controls to the operation memories (such as internal relay area WR).
③	Start enabled control Checks the states of read flags if each control (such as position control, JOG operation, home return) can be started, and outputs the start enabled states to internal relays.
④	Various control programs (such as position control, JOG operation, home return) Checks the results of start enabled controls, and outputs the start requests for position control, JOG operation or home return to the operation memories (such as internal relays).
⑤	Writing to unit memories UM (output control area) Writes the results of the operation memories (such as internal relay area) in which the above operation results are reflected to the unit memories (output control area). Example) Startup of positioning, JOG operation, or home return, stop control

■ Program example

The following program is simplified to show the whole configuration. The reading data from the input control area is inserted in the beginning of the program, and the writing data to the output control area is inserted at the end of the program.

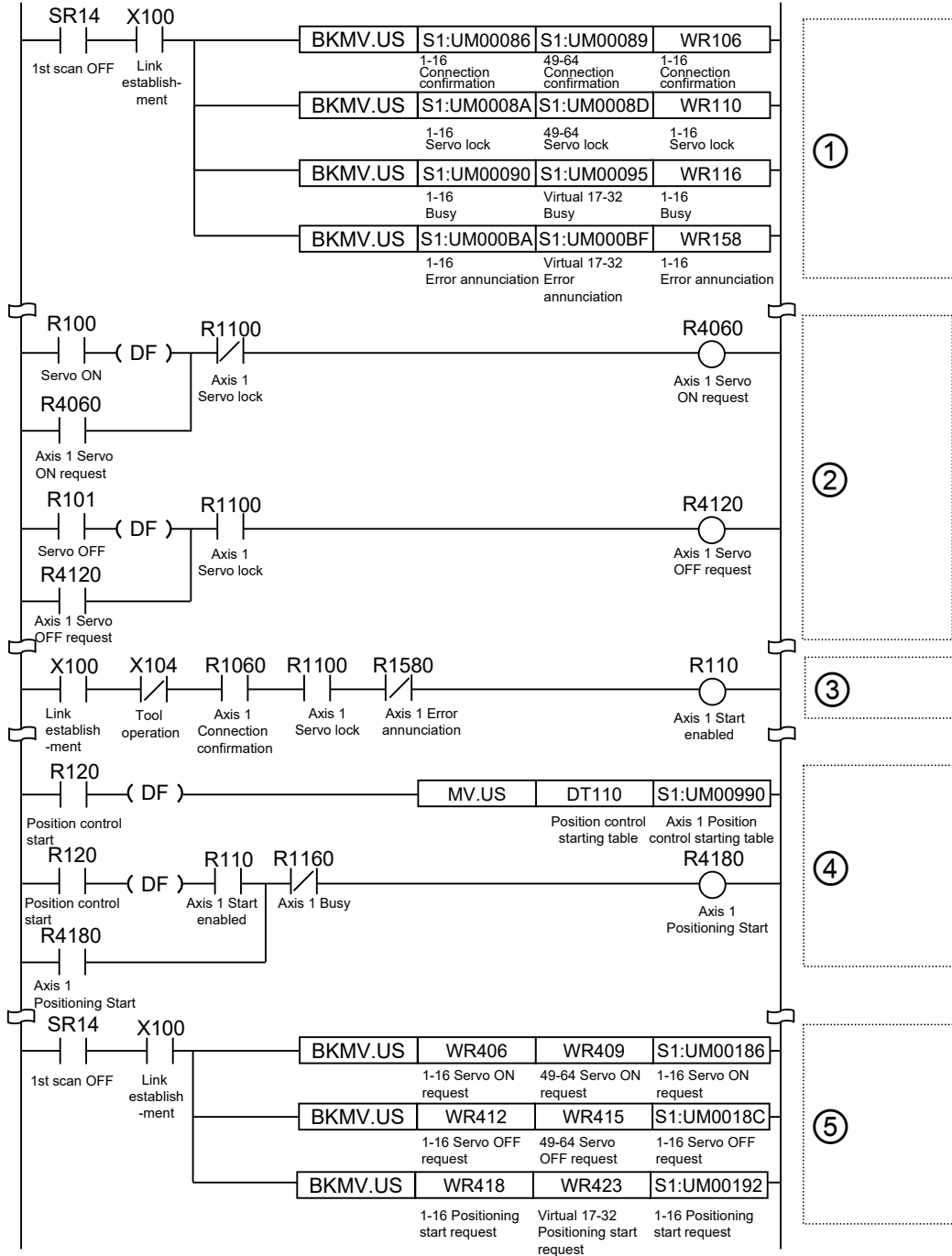

## 7.2 Overview of Programs

### 7.2.1 Reading Data From Input Control Area

- The reading program from the unit memories (input control area) reads and stores flags in the operation memories such as internal relays to enable them to be treated easily in consecutive control programs.
- Most flags are allocated to 1-word (16-bit) unit memory for 16 axes. As for the limit inputs, 2 bits (+ and - sides) are required for 1 axis, therefore, flags for 8 axes are allocated to 1-word (16-bit) unit memory.

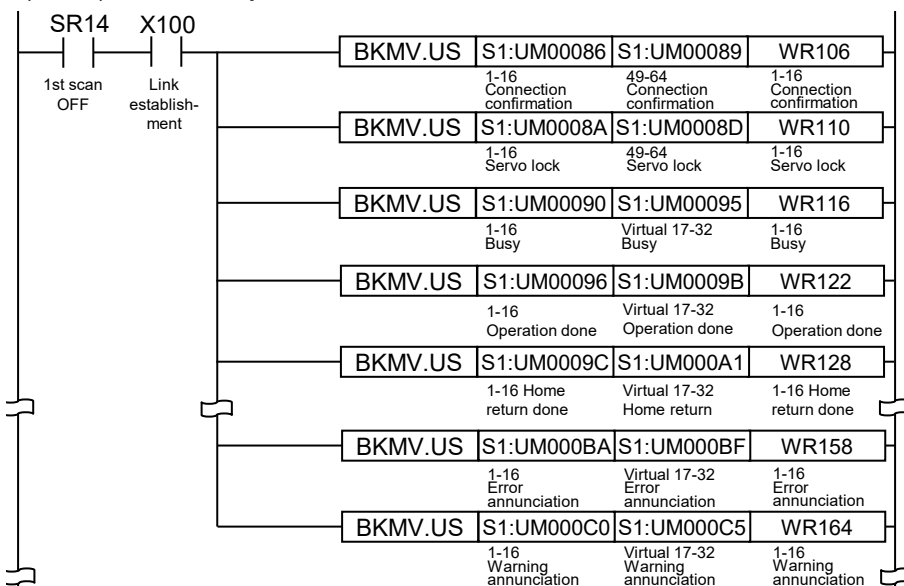

#### ◆ REFERENCE

- For details of the configuration and contents of input control area, refer to "16.4.1 Configuration of Input Control Area" and "16.4.2 List of Input Control Area Functions".

### 7.2.2 Servo ON/OFF Control Program

- The Servo ON/OFF is controlled by writing requests into the unit memories (output control area).
- Create a program to turn on each bit of the unit memories allocated to the Servo ON request signal or Servo OFF request signal. The part of the following ② indicates the control program of axis no. 1.

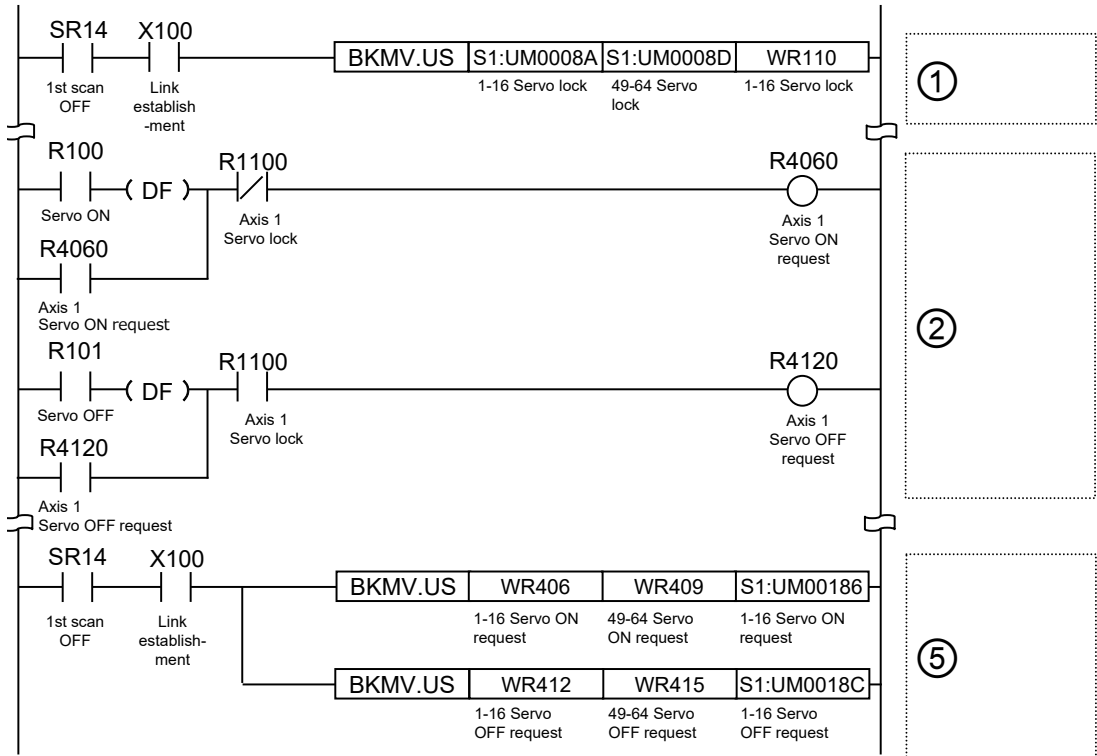

#### Allocation of unit memories

Signal name	Real axis				Virtual axis	
	Axes 1-16	Axes 17-32	Axes 33-48	Axes 49-64	Axes 1-16	Axes 17-32
Servo lock	UM0008A	UM0008B	UM0008C	UM0008D	-	-
Servo ON request	UM00186	UM00187	UM00188	UM00189	-	-
Servo OFF request	UM0018C	UM0018D	UM0018E	UM0018F	-	-

(Note 1): Flags or request signals for 16 axes are allocated to each unit memory (1 word) in the above table.

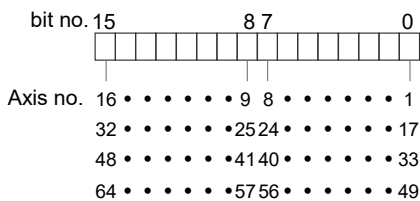

### 7.2.3 Start Enabled Program

- The start enabled control program is inserted to check flags read from the unit memories (input control area) to confirm if each consecutive control (such as position control, JOG operation and home return) can be started.
- Collected start conditions are output as arbitrary start enabled flags (internal relays).

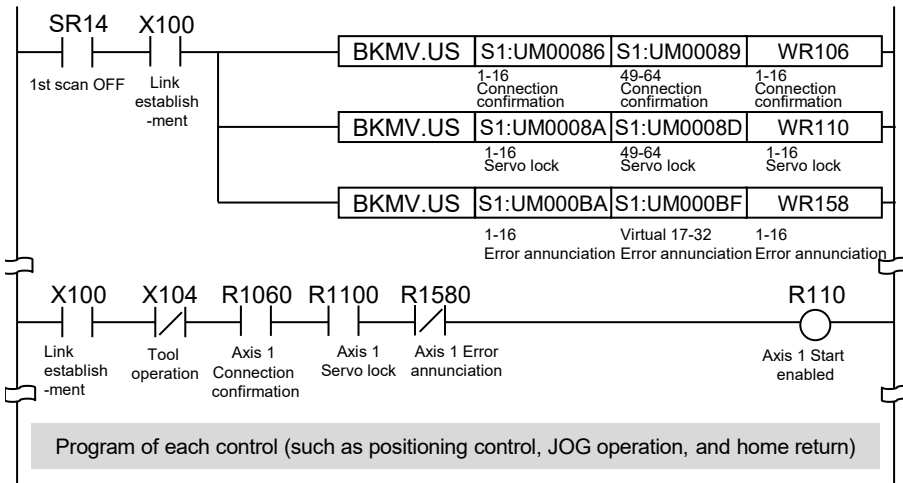

### 7.2.4 Each Control Programs

Each control programs (such as position control, JOG operation and home return) operates the start requests which require the output result of the above start enabled program.



#### ◆ REFERENCE

- For details of positioning control programs, refer to "8.8.1 Sample Programs (E-point, P-point and C-point Controls)".
- For details of JOG operation programs, refer to "10.4.1 Sample Program (JOG Operation)".
- For details of home return programs, refer to "11.3.1 Sample Program (Home Return)".



## 7.2.5 Writing Data to Output Control Area

- The values of the operation memories (such as WR) in which the results operated in each control program are reflected are written to the unit memories (output control area).
- Most flags are allocated to 1-word (16-bit) unit memory for 16-axes. As for JOG operation, 2 bits (forward and reverse) are required for 1 axis; therefore, flags for 8-axes are allocated to 1-word (16-bit) unit memory.

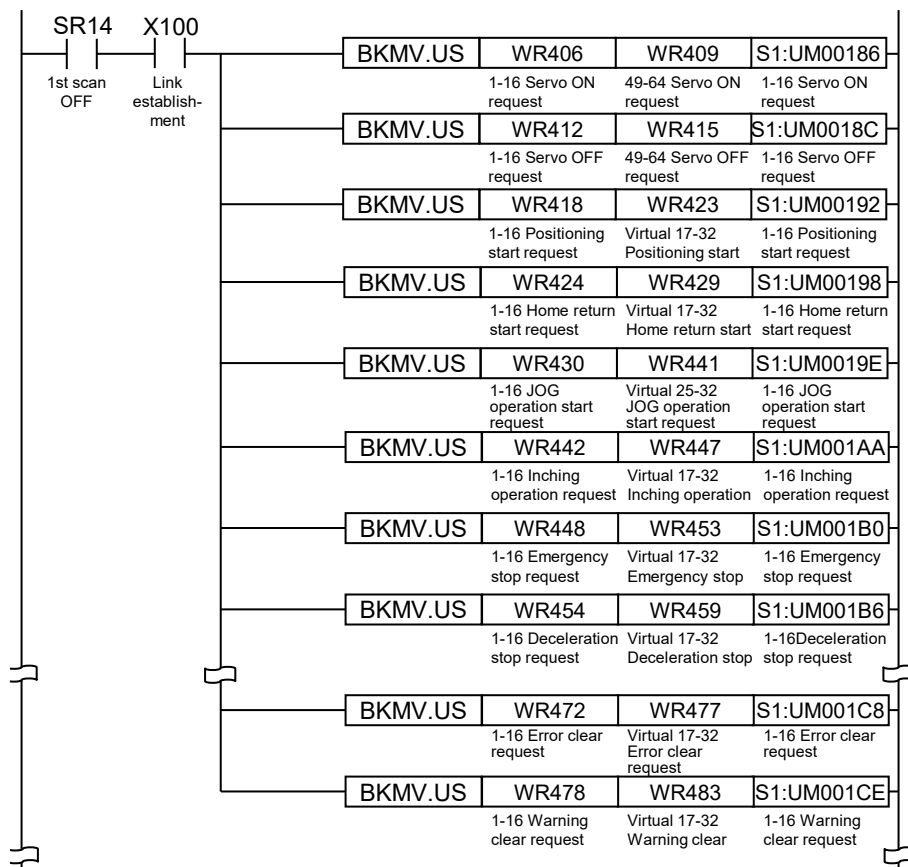

### ◆ REFERENCE

- For details of the configuration and contents of output control area, refer to "16.4.3 Configuration of Output Control Area" and "16.4.4 List of Output Control Area Functions".

## 7.3 Precautions on Programming

---

### 7.3.1 Turning Off Power Supply Clears Contents in Unit Memories

---

- Data in unit memories are cleared when the power is turned off.
- When the power is turned on again, data is preset in the parameters saved in the FROM within FP7 MC Unit.

### 7.3.2 Operation Cannot be Switched Once One Operation Has Started

---

- If any of the startup requests for position control, synchronous control, JOG operation and home return turns on and the operation is initiated, this operation cannot be switched to another operation even if another request turns on.
- BUSY flags corresponding to each axis turn on during operation. Insert them as interlock signals for each start request on user programs.
- The stop operations (system stop, limit stop, error stop, emergency stop and deceleration stop) are preferentially activated even in other operations.

### 7.3.3 Operation When PLC Mode Changes from RUN to PROG.

---

The operation when the mode of the CPU unit changes from RUN to PROG. varies depending on the setting of “RUN > PROG operation” of “MC common settings”.

#### ■ MC common settings

Parameter name	Default	Description	
RUN->PROG. operation	Deceleration stop	Set the operation of FP7 MC Unit when the mode of CPU unit changes from RUN to PROG.	
		Operation continuance	The operation of each axis continues.
		Deceleration stop	Each axis decelerates and stops in a specified deceleration stop time in the current control mode.
		Immediate stop	Each axis decelerates and stops in a specified emergency stop deceleration time.

# 8

## **Automatic Operation (Position Control)**

## 8.1 Basic Operation

### 8.1.1 Patterns of Position Control

- The automatic operation is an operation mode to perform a position control. For the position control, there are a single axis control and an interpolation control that starts and stops multiple axes simultaneously.
- For the operations of position controls, there are E-point, P-point and C-point controls which are performed regardless of single axis control or interpolation axis control. Also, there is J-point control which is activated only by the single axis control. The operation patterns of each control are as follows.

#### ■ Operation pattern

●: Available, -: Not available

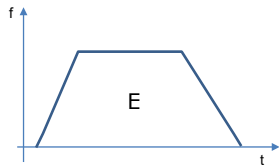
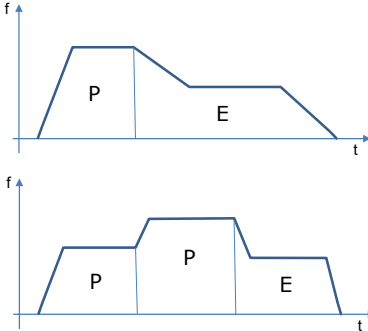
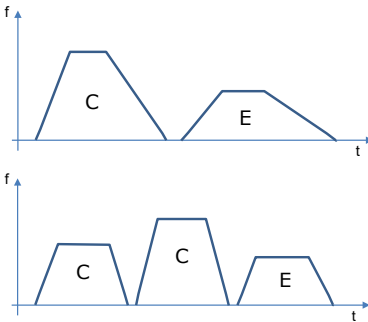
Name	Time chart	Operation and application	Repeat	Interpolation
E-point control		<ul style="list-style-type: none"> <li>● This is a method of control which is initiated up to an end point, and is called "E-point control".</li> <li>● This method is used for a single-speed acceleration/deceleration.</li> </ul>	●	●
P-point control		<ul style="list-style-type: none"> <li>● This refers to control which passes through a "Pass Point", and is called "P-point control".</li> <li>● This method is used for performing acceleration/deceleration by two-speed control or more.</li> <li>● After the P-point control is performed for a specified movement amount, it shifts to the E-point control.</li> <li>● The last table should be set to E: End point.</li> </ul>	●	●
C-point control		<ul style="list-style-type: none"> <li>● This refers to control which passes through a "Continuance Point", and is called "C-point control".</li> <li>● This method is used for performing two successive single-speed positioning control with different target speeds or acceleration/deceleration times.</li> <li>● The time taken until the operation shifts to the next table is specified as a dwell time.</li> <li>● The last table should be set to E: End point.</li> </ul>	●	●

●: Available, -: Not available

Name	Time chart	Operation and application	Repeat	Interpolation				
J-point control	<p>No speed change</p>	<ul style="list-style-type: none"> <li>This refers to control which passes through a speed point "JOG Operation Point", and is called "J-point control".</li> <li>After the start, it is controlled at specified speeds.</li> <li>Once the J-point positioning request turns on, the positioning control (E-point control) starts.</li> <li>When the J-point speed change request is set, the speed changes.</li> </ul> <table border="1"> <tr> <td>①</td> <td>J-point positioning start request</td> </tr> <tr> <td>②</td> <td>J-point speed change contact</td> </tr> </table> <ul style="list-style-type: none"> <li>The last table should be set to E: End point.</li> </ul>	①	J-point positioning start request	②	J-point speed change contact	—	—
	①		J-point positioning start request					
②	J-point speed change contact							
<p>Speed changes</p>								

**■ Selection of operation patterns**

The positioning operation mode is selected in the "Positioning table setting" menu of CMI.

- For the E-point control, input settings in one row.
- For P-point, C-point and J-point controls, input settings to make the last table to be the E-point control in combination.

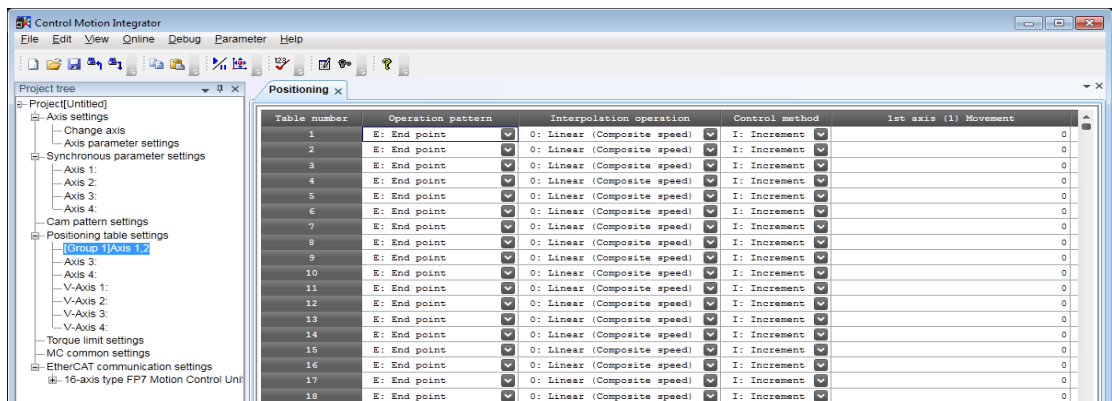

**■ Settings of J-point control**

- Set the positioning unit to increment mode to implement P-point control, C-point control, or E-point control with positions specified after J-point control is implemented.
- For changing the speed during the J-point control, set the acceleration/deceleration time and target speed when the speed is changed in the "Axis parameter" menu of CMI.

### 8.1.2 Setting and Operation of E-point Control

In the following example, a single-speed acceleration/deceleration control is performed by a single-axis control.

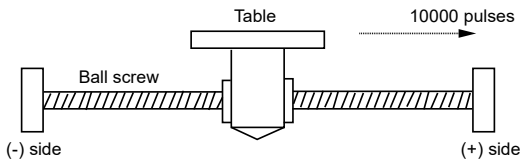

#### ■ Settings

Item	Setting example
Operation pattern	E: End point
Control method	I: Increment
1st axis (L) movement amount	10000 pulses
Acceleration/deceleration type	L: Linear
Acceleration time (ms)	100 ms
Deceleration time (ms)	100 ms
Target speed	10000 pps

(Note): The (L) in the above table is an axis number.

#### ■ Operation diagram

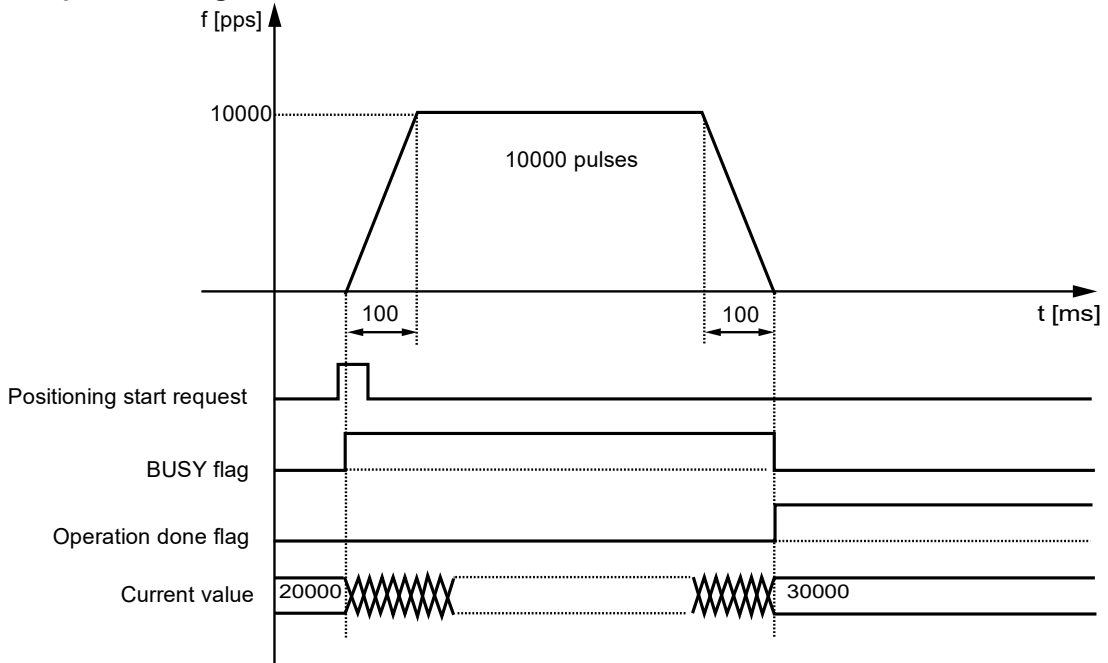

■ Operation of input control/output control signals

- When a positioning start request (corresponding bit allocated to UM00192 to UM00197) turns on by a user program, the positioning control will start. The positioning start request will be enabled at the edge where it turns on.
- A busy flag (corresponding bit allocated to UM00090 to UM00095), which indicates that a requested operation is being controlled, will turn on when the positioning control starts, and it will turn off when the operation completes.
- An operation done flag (corresponding bit allocated to UM00096 to UM0009B), which indicates the completion of operation, will turn on when the current operation is completed, and it will be held until the next positioning control, JOG operation, or home return starts.

■ Allocation of unit memories

Signal name	Real axis				Virtual axis	
	Axes 1-16	Axes 17-32	Axes 33-48	Axes 49-64	Axes 1-16	Axes 17-32
Positioning start request	UM00192	UM00193	UM00194	UM00195	UM00196	UM00197
BUSY flag	UM00090	UM00091	UM00092	UM00093	UM00094	UM00095
Operation done flag	UM00096	UM00097	UM00098	UM00099	UM0009A	UM0009B

(Note 1): Flags or request signals for 16 axes are allocated to each unit memory (1 word) in the above table. When the value of each bit is 1, it turns on. When the value of each bit is 0, it turns off.

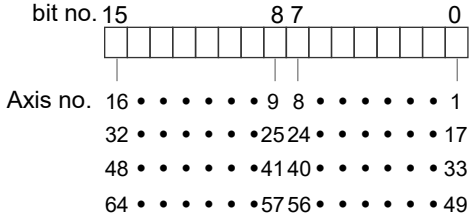

### 8.1.3 Setting and Operation of P-point Control

In the following example, a three-speed acceleration/deceleration control is performed by a single-axis control.

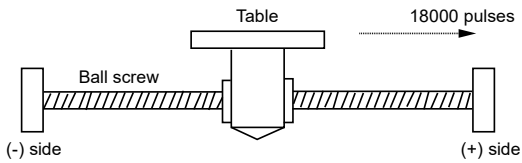

#### ■ Settings

Item	Setting example		
	Table 1	Table 2	Table 3
Operation pattern	P: Pass point	P: Pass point	E: End point
Control method	I: Increment	I: Increment	I: Increment
1st axis (L) movement amount	5000 pulses	10000 pulses	3000 pulses
Acceleration/deceleration type	L: Linear	L: Linear	L: Linear
Acceleration time (ms)	100 ms	200 ms	30 ms
Deceleration time (ms)	10 ms	20 ms	150 ms
Target speed	10000 pps	20000 pps	5000 pps

(Note): The (L) in the above table is an axis number.

#### ■ Operation diagram

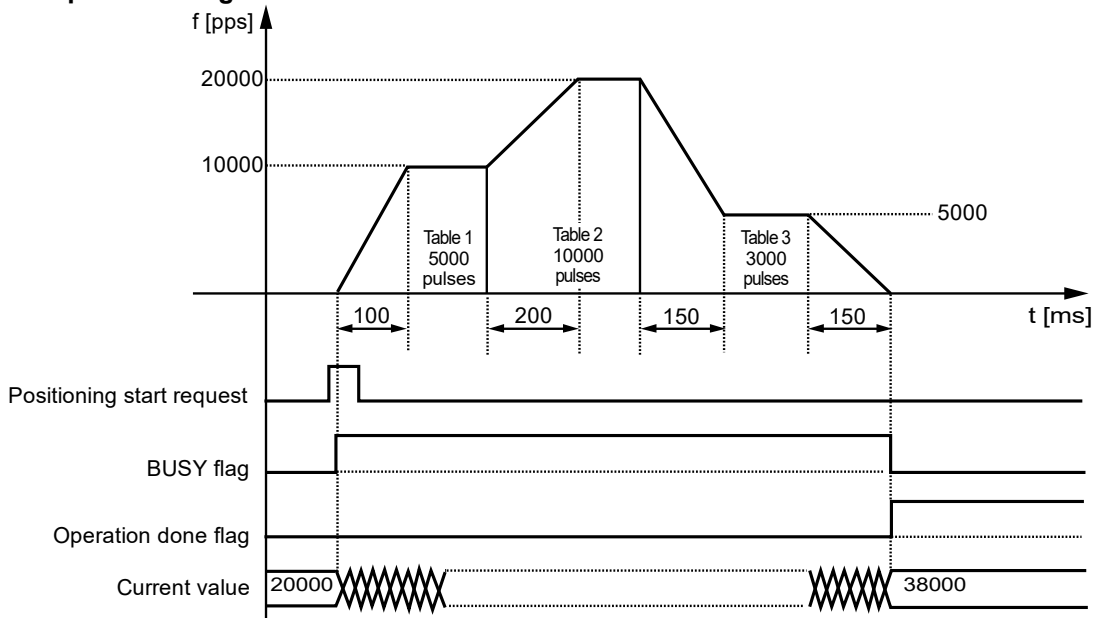





### 8.1.4 Setting and Operation of C-point Control

In the following example, three successive acceleration/deceleration controls are performed by a single-axis control.

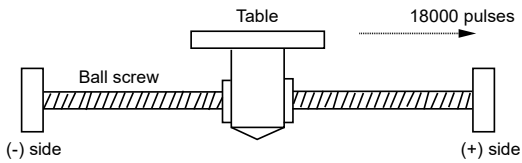

#### ■ Settings

Item	Setting example		
	Table 1	Table 2	Table 3
Operation pattern	C: Continuance point	C: Continuance point	E: End point
Control method	I: Increment	I: Increment	I: Increment
1st axis (L) movement amount	5000 pulses	10000 pulses	3000 pulses
Acceleration/deceleration type	L: Linear	L: Linear	L: Linear
Acceleration time (ms)	100 ms	200 ms	30 ms
Deceleration time (ms)	10 ms	20 ms	150 ms
Target speed	10000 pps	20000 pps	5000 pps

(Note): The (L) in the above table is an axis number.

#### ■ Operation diagram

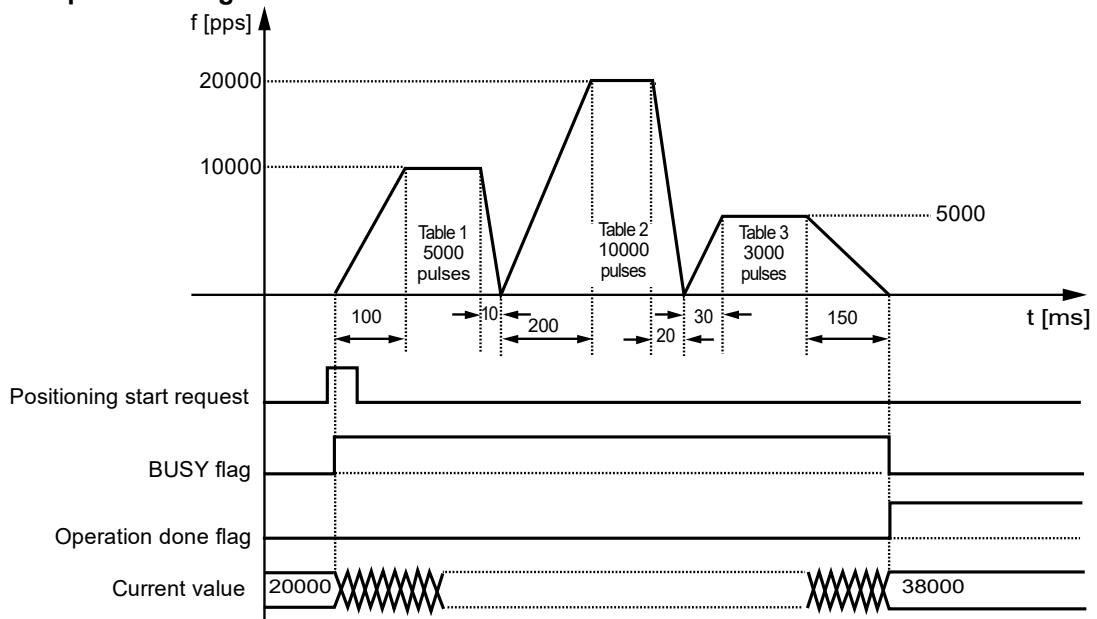

### ■ Operation of input control/output control signals

- When a positioning start request (corresponding bit allocated to UM00192 to UM00197) turns on by a user program, the positioning control will start. The positioning start request will be enabled at the edge where it turns on.
- A busy flag (corresponding bit allocated to UM00090 to UM00095), which indicates that a requested operation is being controlled, will turn on when the positioning control starts, and it will turn off when the operation completes.
- An operation done flag (corresponding bit allocated to UM00096 to UM0009B), which indicates the completion of operation, will turn on when the current operation is completed, and it will be held until the next positioning control, JOG operation, or home return starts.

### ■ Allocation of unit memories

Signal name	Real axis				Virtual axis	
	Axes 1-16	Axes 17-32	Axes 33-48	Axes 49-64	Axes 1-16	Axes 17-32
Positioning start request	UM00192	UM00193	UM00194	UM00195	UM00196	UM00197
BUSY flag	UM00090	UM00091	UM00092	UM00093	UM00094	UM00095
Operation done flag	UM00096	UM00097	UM00098	UM00099	UM0009A	UM0009B

(Note 1): Flags or request signals for 16 axes are allocated to each unit memory (1 word) in the above table. When the value of each bit is 1, it turns on. When the value of each bit is 0, it turns off.

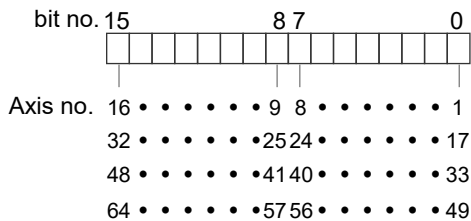

### 8.1.5 Setting and Operation of J-point Control

In the following example, a J-point control is performed by a single-axis control. The unit operates at the target speed and J-point target speed until the J-point positioning start request turns on (without depending on a set movement amount). The position control starts once the J-point positioning start request turns on.

■ Settings

Item	Setting example			
	Table 1	J-point axis parameter setting	Table 2	Table 3
Operation pattern	J: Speed point	—	P: Pass point	E: End point
Control method	I: Increment	—	I: Increment	I: Increment
1st axis (L) movement amount	5000 pulses	—	10000 pulses	3000 pulses
Acceleration/deceleration type	L: Linear	—	L: Linear	L: Linear
Acceleration time (ms)	100 ms	—	200 ms	30 ms
Deceleration time (ms)	10 ms	—	20 ms	150 ms
Target speed	10000 pps	—	20000 pps	5000 pps
J-point operation setting code	—	Linear acceleration/ deceleration	—	—
J-point acceleration time (ms)	—	10 ms	—	—
J-point deceleration time (ms)	—	10 ms	—	—
J-point target speed	—	30000 pps	—	—

(Note): The (L) in the above table is an axis number.

■ Operation diagram

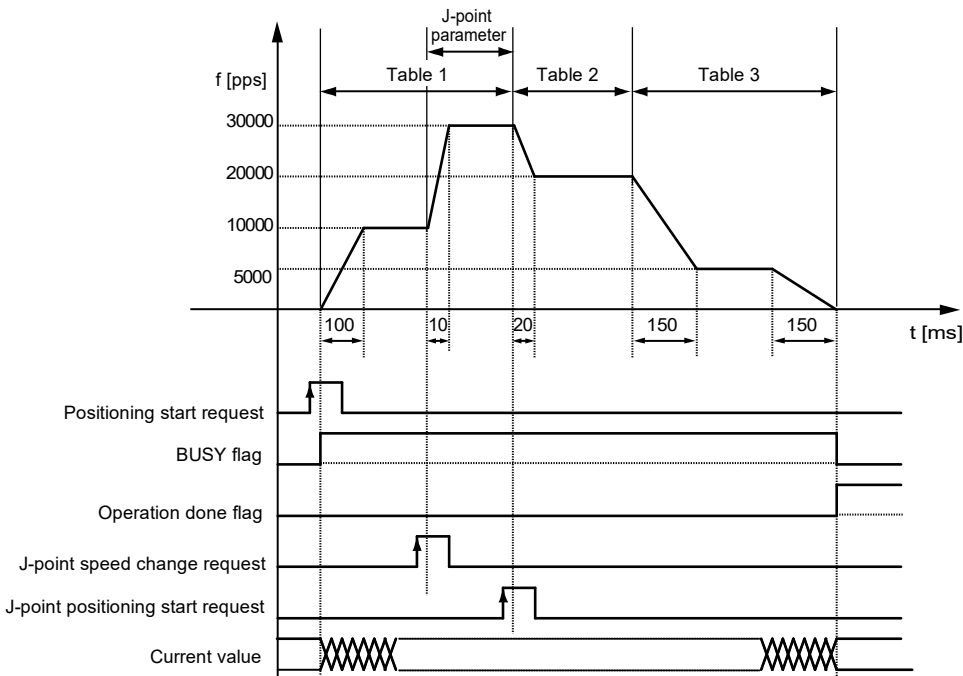

### ■ Operation of input control/output control signals

- When a positioning start request (corresponding bit allocated to UM00192 to UM00197) turns on by a user program, the positioning control will start. The positioning start request will be enabled at the edge where it turns on.
- A busy flag (corresponding bit allocated to UM00090 to UM00095), which indicates that a requested operation is being controlled, will turn on when the positioning control starts, and it will turn off when the operation completes.
- An operation done flag (corresponding bit allocated to UM00096 to UM0009B), which indicates the completion of operation, will turn on when the current operation is completed, and it will be held until the next positioning control, JOG operation, or home return starts.
- When a J-point speed change request (corresponding bit allocated to UM001BC to UM001C1) turns on, the target speed will change. The speed change request will be enabled at the edge where it turns on.
- When a J-point positioning start request (corresponding bit allocated to UM001C2 to UM001C7) turns on, the next positioning control will start.

### ■ Allocation of unit memories

Signal name	Real axis				Virtual axis	
	Axes 1-16	Axes 17-32	Axes 33-48	Axes 49-64	Axes 1-16	Axes 17-32
Positioning start request	UM00192	UM00193	UM00194	UM00195	UM00196	UM00197
BUSY flag	UM00090	UM00091	UM00092	UM00093	UM00094	UM00095
Operation done flag	UM00096	UM00097	UM00098	UM00099	UM0009A	UM0009B
J-point speed change request	UM001BC	UM001BD	UM001BE	UM001BF	UM001C0	UM001C1
J-point positioning start request	UM001C2	UM001C3	UM001C4	UM001C5	UM001C6	UM001C7

(Note 1): Flags or request signals for 16 axes are allocated to each unit memory (1 word) in the above table. When the value of each bit is 1, it turns on. When the value of each bit is 0, it turns off.

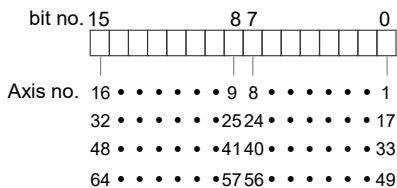

### ■ Behaviors when the speed change request turns on while the positioning unit is accelerating or decelerating the speed

A speed change is possible during J-point control, but impossible during acceleration or deceleration. A speed change will be made after the unit goes to constant speed when the speed change signal turns on during acceleration or deceleration. Be sure to input the amount of movement for positioning with a value that can secure a target constant-speed area.

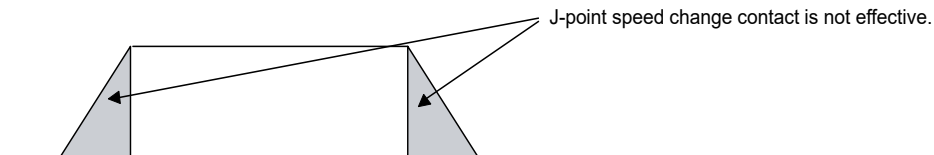

## 8.2 Interpolation Control

---

### 8.2.1 Type of Interpolation Control (2-Axis Interpolation)

---

- The following types and operation specification methods are available for the 2-axis interpolation.
- The axes in the relation of an interpolation are called 1st axis and 2nd axis for the 2-axis interpolation. Also, the 1st axis and 2nd axis are automatically allocated from the smallest axis number in ascending order.

#### ■ Type and operation specification method

Type	Operation specification method	Necessary data
2-axis linear interpolation control	Composite speed	Composite speed of 1st axis and 2nd axis
	Long axis speed	Speed of long axis (Axis of which moving distance is long)
2-axis circular interpolation control	Center point/CW direction	Coordinates of 1st axis and 2nd axis of center point
	Center point/CCW direction	Coordinates of 1st axis and 2nd axis of center point
	Pass point	Coordinates of 1st axis and 2nd axis of pass point on arc

#### ■ Positioning table and operation characteristics

- When specifying the long axis speed method, the composite speed is faster than the long axis speed.
- In the case of the center point specification, the coordinate of the center point on arc is specified as the data of 1st-axis (X-axis) auxiliary point and 2nd-axis (Y-axis) auxiliary point of positioning data. Also, In the case of the pass point specification, the coordinate of the pass point on arc is specified as the data of 1st-axis (X-axis) auxiliary point and 2nd-axis (Y-axis) auxiliary point of positioning data.
- When the control method is increment, for the both center point and pass point, the increment coordinate from the start point is specified.
- When the start point and the operation done point is the same, it performs one circular operation when using the center point method. However, when using the pass point method, an error occurs.
- In case of the pass point method, when the start point, pass point and operation done point exist in the same straight line, an arc is not comprised, and an error occurs.
- In each interpolation control, the E-point control which uses one table, P-point control and C-point control which uses multiple tables can be combined arbitrarily as positioning data. For the P-point and C-point controls, the last table should be set as an end point.



#### ◆ REFERENCE

---

- For details of E-point, P-point, and C-point controls, refer to "8.1.1 Patterns of Position Control".

2-axis linear interpolation  
(Composite speed specification)

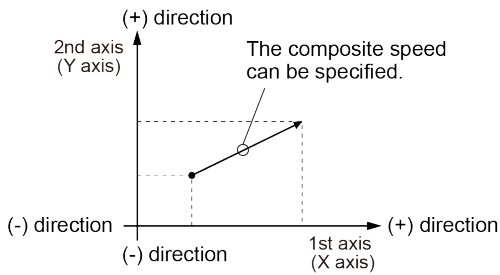

2-axis linear interpolation  
(Long axis speed specification)

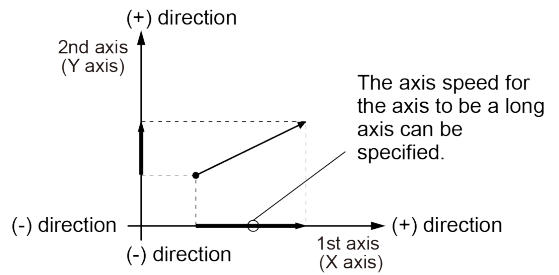

2-axis circular interpolation  
(Center point specification/CW direction)

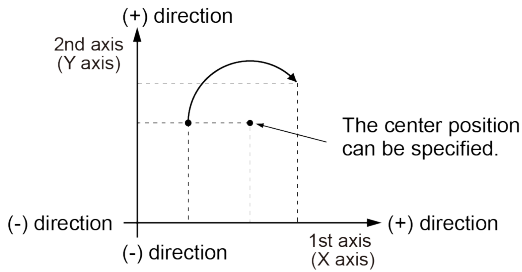

2-axis circular interpolation  
(Center point specification/CCW direction)

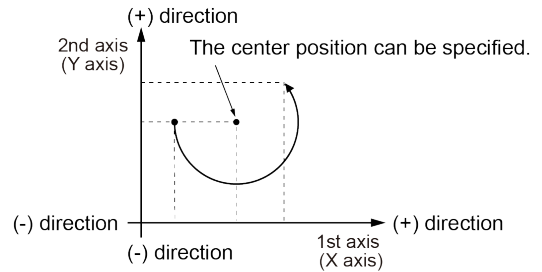

2-axis circular interpolation  
(Pass point specification)

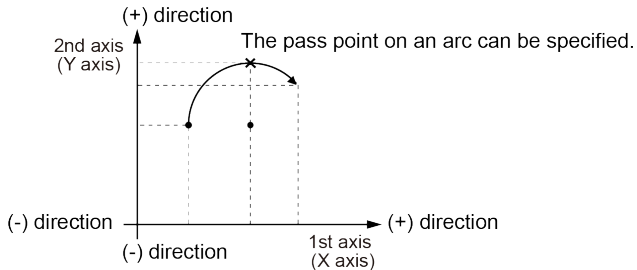

### 8.2.2 Setting and Operation of 2-Axis Linear Interpolation

In the following example, a 2-axis linear interpolation control is performed by a composite speed.

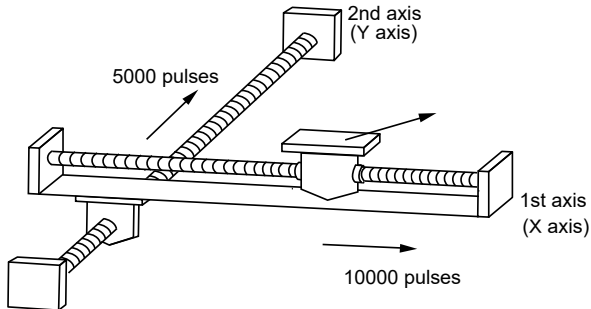

■ Settings

Item	Setting example	Remark
Operation pattern	E: End point	
Interpolation operation	0: Linear (Composite speed)	
Control method	I: Increment	
1st axis (L) movement amount	10000 pulses	Axis numbers are put in (L) and (m). The values of auxiliary points are invalid for the linear interpolation.
1st axis (L) auxiliary point	0 pulses	
2nd axis (m) movement amount	5000 pulses	
2nd axis (m) auxiliary point	0 pulses	
Acceleration/deceleration type	L: Linear	
Acceleration time (ms)	100 ms	
Deceleration time (ms)	100 ms	
Interpolation speed	10000 pps	



### ■ Operation diagram

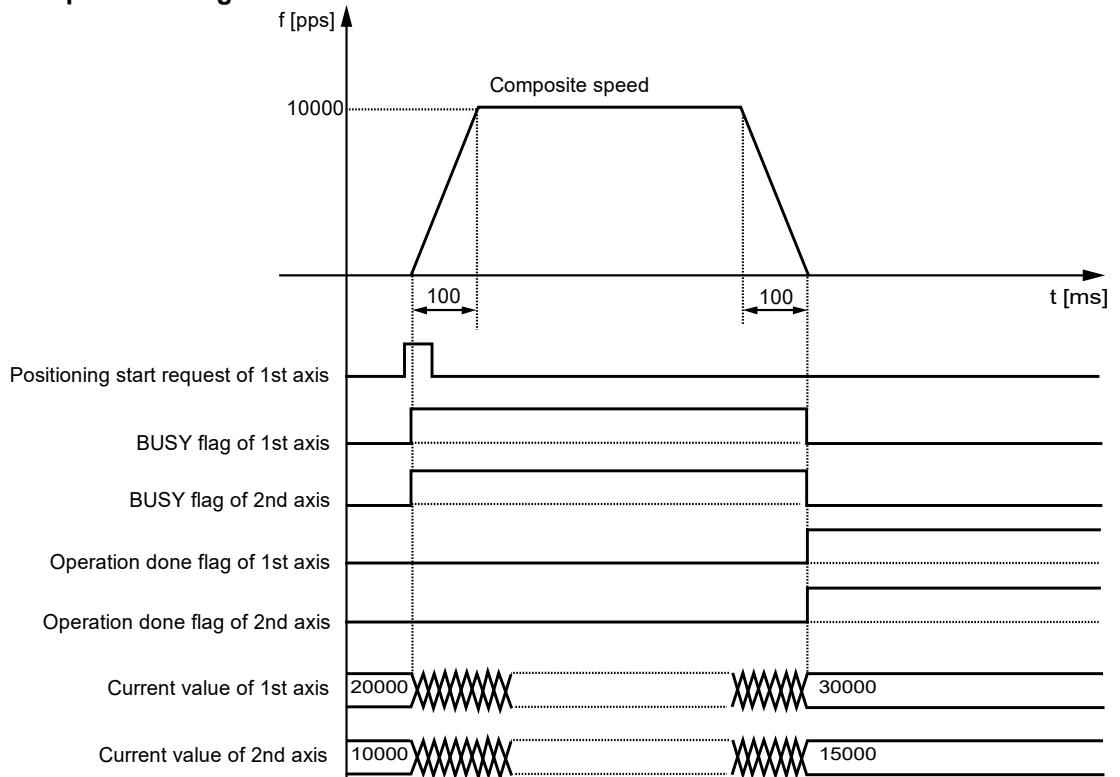

### ■ Operation of input control/output control signals

- When a positioning start request (corresponding bit allocated to UM00192 to UM00197) turns on by a user program, the positioning control will start. The positioning start request will be enabled at the edge where it turns on. In the interpolation control, turn on the positioning start request of the smallest axis number in the same interpolation group.
- A busy flag (corresponding bit allocated to UM00090 to UM00095), which indicates that a motor is running, will turn on when the positioning control starts, and it will turn off when the operation completes.
- An operation done flag (corresponding bit allocated to UM00096 to UM0009B), which indicates the completion of operation, will turn on when the current operation is completed, and it will be held until the next positioning control, JOG operation, or home return starts.

### 8.2.3 Setting and Operation of 2-Axis Circular Interpolation

In the following example, a 2-axis circular interpolation control is performed by specifying the center point.

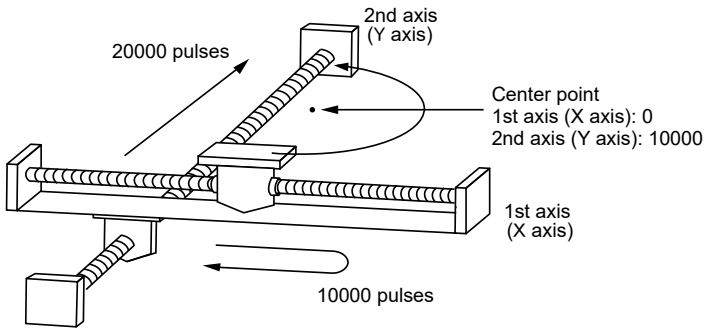

#### ■ Settings

Item	Setting example	Remark
Operation pattern	E: End point	
Interpolation operation	S: Circular (Pass point/CW direction)	
Control method	I: Increment	
1st axis (L) movement amount	0 pulses	Axis numbers are put in (L) and (m). For the auxiliary points, specify the coordinate (0, 10000) to be the center of an arc.
1st axis (L) auxiliary point	0 pulses	
2nd axis (m) movement amount	20000 pulses	
2nd axis (m) auxiliary point	10000 pulses	
Acceleration/deceleration type	L: Linear	
Acceleration time (ms)	100 ms	
Deceleration time (ms)	100 ms	
Interpolation speed	10000 pps	Specify the speed of a tangent of an arc.

### ■ Operation diagram

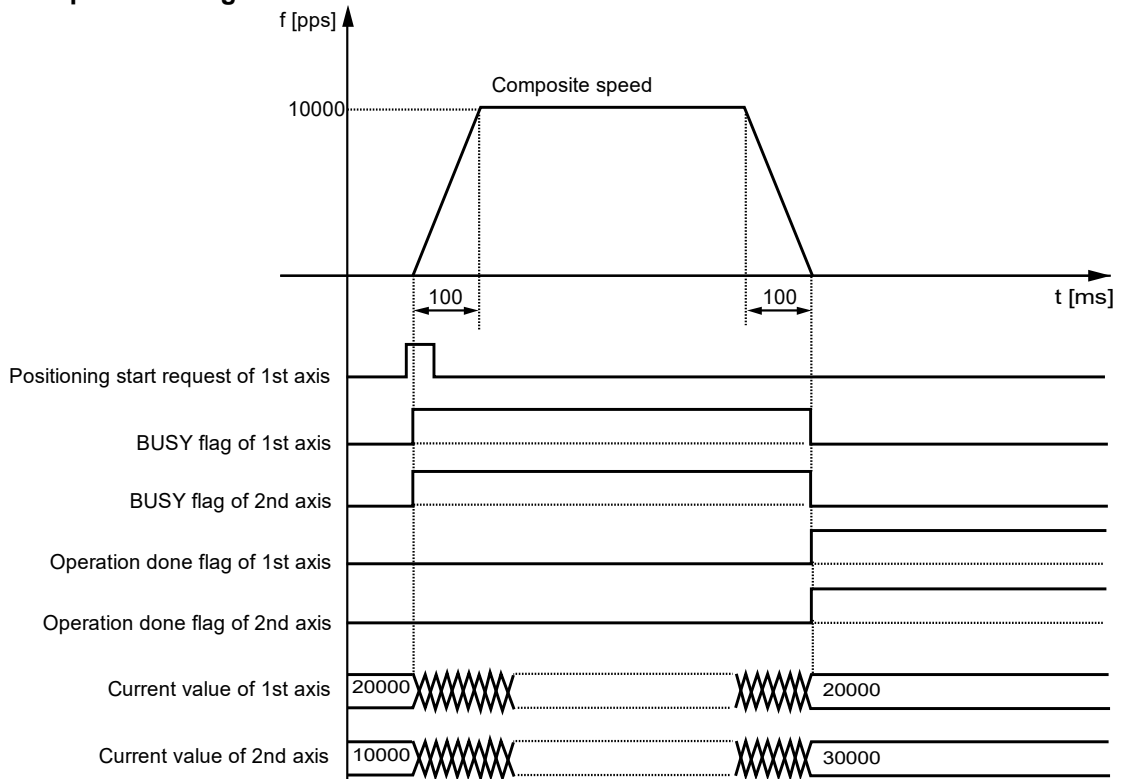

### ■ Operation of input control/output control signals

- When a positioning start request (corresponding bit allocated to UM00192 to UM00197) turns on by a user program, the positioning control will start. The positioning start request will be enabled at the edge where it turns on. In the interpolation control, turn on the positioning start request of the smallest axis number in the same interpolation group.
- A busy flag (corresponding bit allocated to UM00090 to UM00095), which indicates that a motor is running, will turn on when the positioning control starts, and it will turn off when the operation completes.
- An operation done flag (corresponding bit allocated to UM00096 to UM0009B), which indicates the completion of operation, will turn on when the current operation is completed, and it will be held until the next positioning control, JOG operation, or home return starts.

### 8.2.4 Type of Interpolation Control (3-axis Interpolation)

- The following types and operation specification methods are available for the 3-axis interpolation.
- The axes in the relation of an interpolation are called 1st axis, 2nd axis and 3rd axis for the 3-axis interpolation. Also, the 1st, 2nd and 3rd axes are automatically allocated from the smallest axis number in ascending order.

**■ Type and operation specification method**

Type	Operation specification method	Necessary data
3-axis linear interpolation control	Composite speed	Composite speed of 1st, 2nd and 3rd axes
	Long axis speed	Speed of long axis (Axis of which moving distance is long)
3-axis spiral interpolation control	Center point/CW direction/1st axis movement	Coordinates of 2nd and 3rd axes of center point
	Center point/CCW direction/1st axis movement	Coordinates of 2nd and 3rd axes of center point
	Center point/CW direction/2nd axis movement	Coordinates of 1st and 3rd axes of center point
	Center point/CCW direction/2nd axis movement	Coordinates of 1st and 3rd axes of center point
	Center point/CW direction/3rd axis movement	Coordinates of 1st and 2nd axes of center point
	Center point/CCW direction/3rd axis movement	Coordinates of 1st and 2nd axes of center point
	Pass point/1st axis movement	Coordinates of 2nd and 3rd axes of pass point on arc
	Pass point/2nd axis movement	Coordinates of 1st and 3rd axes of pass point on arc
	Pass point/3rd axis movement	Coordinates of 1st axis and 2nd axis of pass point on arc

**■ Positioning table and operation characteristics**

- When specifying the long axis speed method, the composite speed is faster than the long axis speed.
- In the case of the center point specification, the coordinates of the center point for two axes which draw an arc is specified as the data of 1st-axis (X-axis) auxiliary point and 2nd-axis (Y-axis) auxiliary point of positioning data. Also, in the case of the pass point specification, the coordinate of the pass point on arc is specified as the data of 1st-axis (X-axis) auxiliary point and 2nd-axis (Y-axis) auxiliary point of positioning data.
- When the control method is increment, for the both center point and pass point, the increment coordinate from the start point is specified.
- When the start point and the operation done point is the same, it performs one circular operation when using the center point method. However, when using the pass point method, an error occurs.
- In case of the pass point method, when the start point, pass point and operation done point exist in the same straight line, an arc is not comprised, and an error occurs.
- In each interpolation control, the E-point control which uses one table, P-point control and C-point control which uses multiple tables can be combined arbitrarily as positioning data. For the P-point and C-point controls, the last table should be set as an end point.



◆ REFERENCE

- For details of the position control patterns, refer to "8.1.1 Patterns of Position Control".

3-axis linear interpolation  
(Composite speed specification)

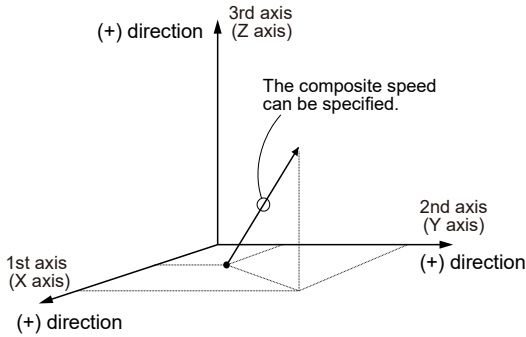

3-axis linear interpolation  
(Long axis speed specification)

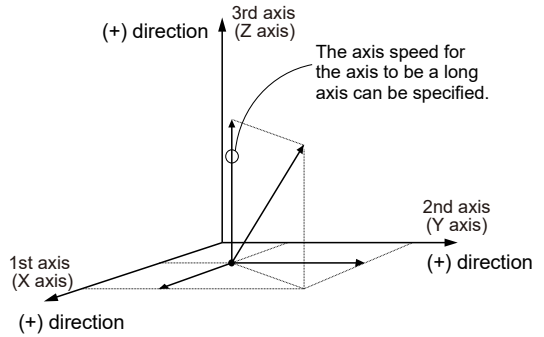

3-axis spiral interpolation (Center point specification/  
CW direction/Z-axis movement)

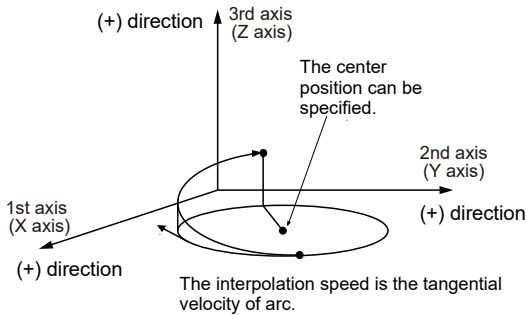

3-axis spiral interpolation (Center point specification/  
CCW direction/Z-axis movement)

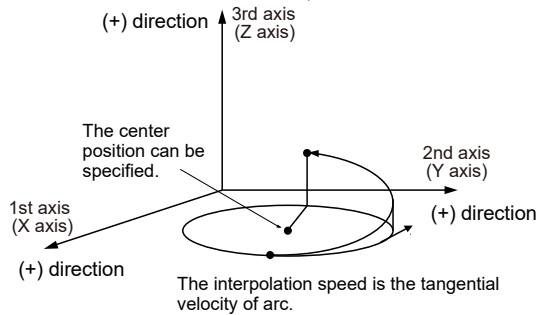

3-axis spiral interpolation (Pass point specification/  
Z-axis movement)

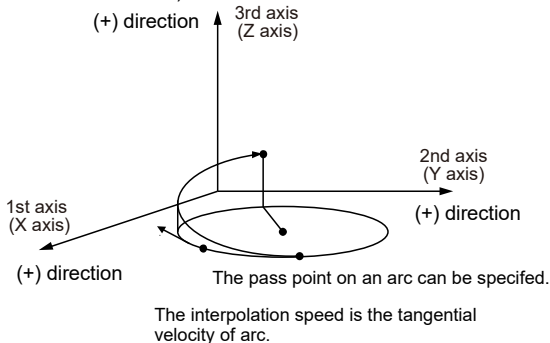

(Note): The following explanatory drawings for 3-axis spiral interpolation control show the cases that an arc is drawn with the 1st axis (X-axis) and 2nd axis (Y-axis) and moves toward the 3rd axis (Z-axis).

### 8.2.5 Setting and Operation of 3-Axis Linear Interpolation

In the following example, a 3-axis linear interpolation control is performed by a composite speed.

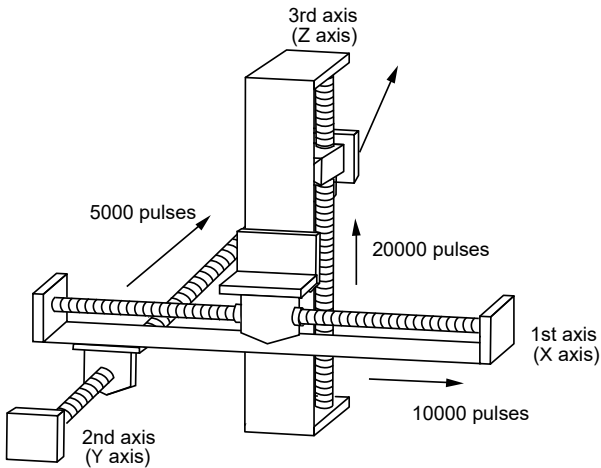

#### ■ Settings

Item	Setting example	Remarks
Operation pattern	E: End point	
Interpolation operation	0: Linear (Composite speed)	
Control method	I: Increment	
1st axis (L) movement amount	10000 pulses	Axis numbers are put in (L), (m) and (n). The values of auxiliary points are invalid for the linear interpolation.
1st axis (L) auxiliary point	0	
2nd axis (m) movement amount	5000 pulses	
2nd axis (m) auxiliary point	0	
3rd axis (n) movement amount	20000 pulses	
3rd axis (n) auxiliary point	0	
Acceleration/deceleration type	L: Linear	
Acceleration time (ms)	100 ms	
Deceleration time (ms)	100 ms	
Interpolation speed	10000 pps	Specify the speed of a tangent of an arc.

### ■ Operation diagram

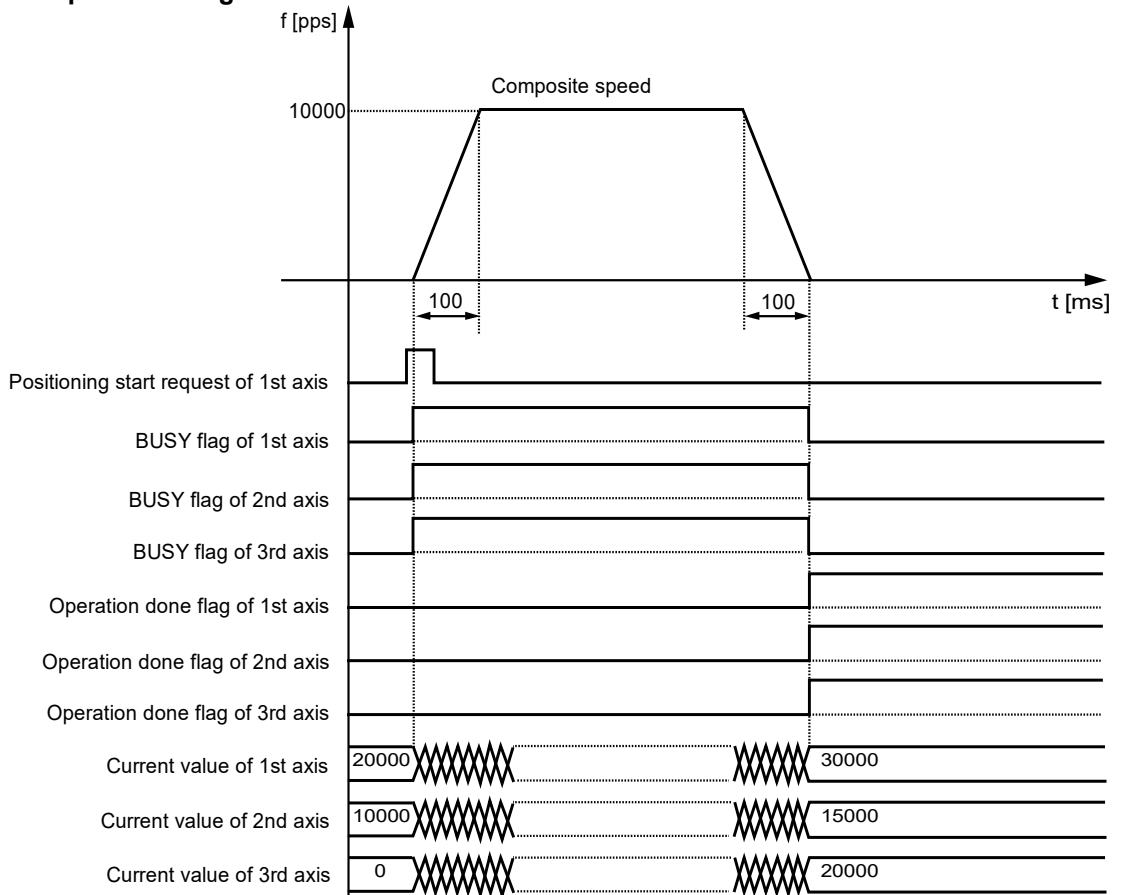

### ■ Operation of input control/output control signals

- When a positioning start request (corresponding bit allocated to UM00192 to UM00197) turns on by a user program, the positioning control will start. The positioning start request will be enabled at the edge where it turns on. In the interpolation control, turn on the positioning start request of the smallest axis number in the same interpolation group.
- A busy flag (corresponding bit allocated to UM00090 to UM00095), which indicates that a motor is running, will turn on when the positioning control starts, and it will turn off when the operation completes.
- An operation done flag (corresponding bit allocated to UM00096 to UM0009B), which indicates the completion of operation, will turn on when the current operation is completed, and it will be held until the next positioning control, JOG operation, or home return starts.

### 8.2.6 Setting and Operation of 3-Axis Spiral Interpolation

In the following example, an arc is drawn with the 1st axis (X-axis) and 2nd axis (Y-axis), and a 3-axis spiral interpolation control is performed with 3rd axis (Z-axis) movement.

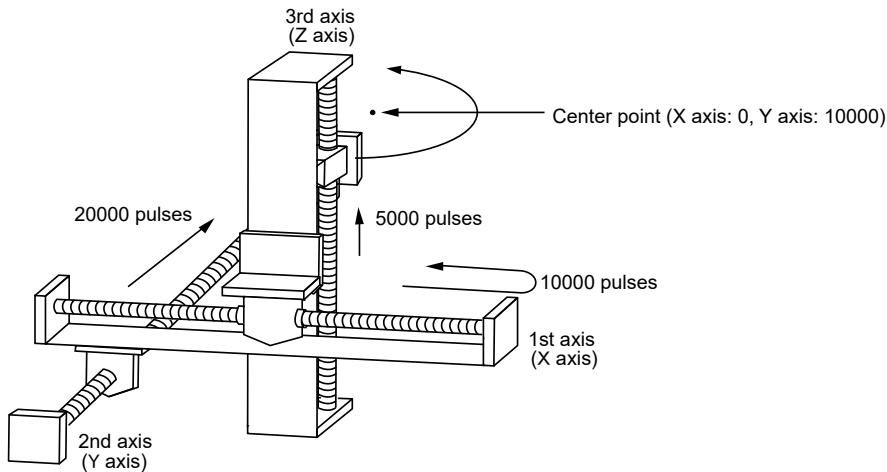

#### ■ Settings

Item	Setting example	Remarks
Operation pattern	E: End point	
Interpolation operation	E: Spiral (Center point/CW direction/3rd axis movement)	
Control method	I: Increment	
1st axis (L) movement amount	0 pulse	Axis numbers are put in (L) and (m). For the auxiliary points, specify the coordinate (0, 10000) to be the center of an arc.
1st axis (L) auxiliary point	0 pulse	
2nd axis (m) movement amount	20000 pulses	Axis numbers are put in (n). Specify the movement amount of 3rd axis (Z-axis).
2nd axis (m) auxiliary point	10000 pulses	
3rd axis (n) movement amount	5000 pulses	
3rd axis (n) auxiliary point	0 pulse	
Acceleration/deceleration type	L: Linear	
Acceleration time (ms)	100 ms	
Deceleration time (ms)	100 ms	
Interpolation speed	10000 pps	



### ■ Operation diagram

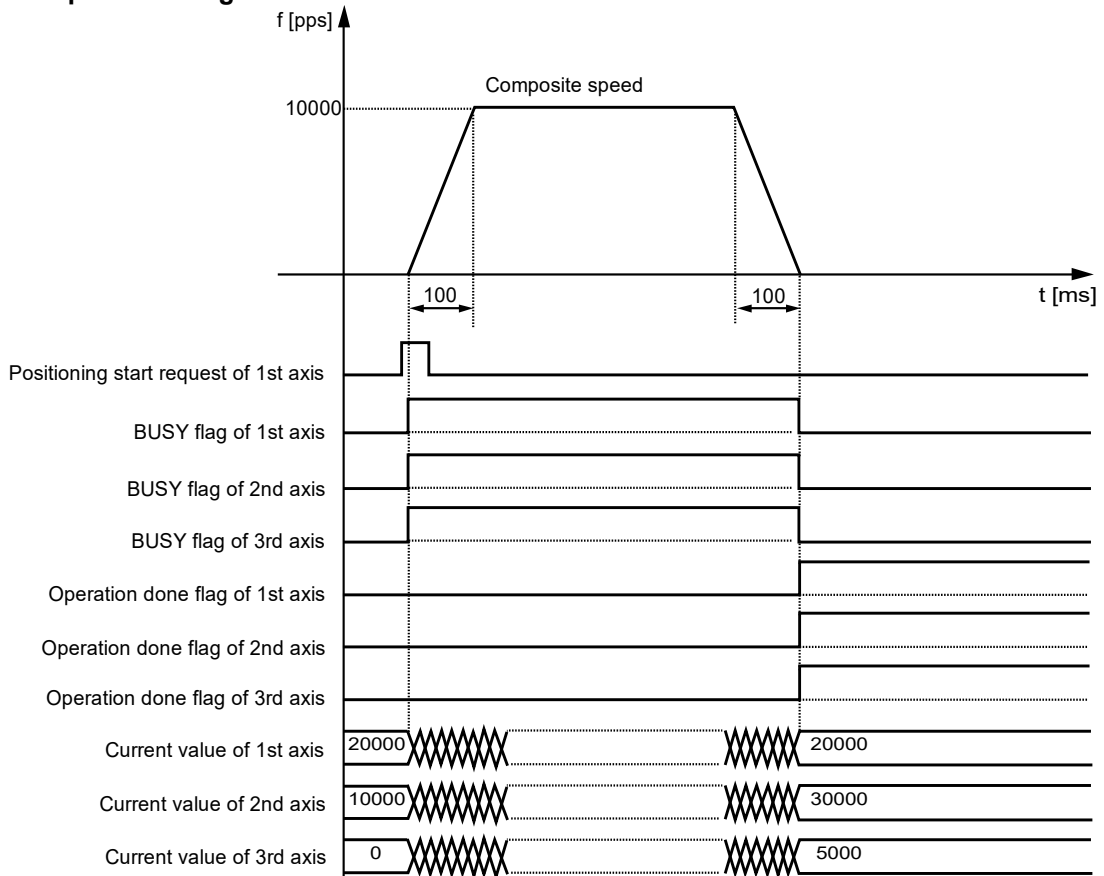

### ■ Operation of input control/output control signals

- When a positioning start request (corresponding bit allocated to UM00192 to UM00197) turns on by a user program, the positioning control will start. The positioning start request will be enabled at the edge where it turns on. In the interpolation control, turn on the positioning start request of the smallest axis number in the same interpolation group.
- A busy flag (corresponding bit allocated to UM00090 to UM00095), which indicates that a motor is running, will turn on when the positioning control starts, and it will turn off when the operation completes.
- An operation done flag (corresponding bit allocated to UM00096 to UM0009B), which indicates the completion of operation, will turn on when the current operation is completed, and it will be held until the next positioning control, JOG operation, or home return starts.

## 8.3 Repeat Function

### 8.3.1 Overview of Repeat Operation

- This function is used to execute continuous positioning control by specifying a repeat count.
- The repeat count is set in the "positioning repeat count area" in the unit memories. The continuous positioning control can be executed in the range of 2 to 254 times or unlimitedly according to the setting.
- The operation from the positioning control starting table to the E-point table is repeated.

#### ■ Overview of Positioning repeat function

The positioning unit operates as shown below in the case of repeating positioning control three times.

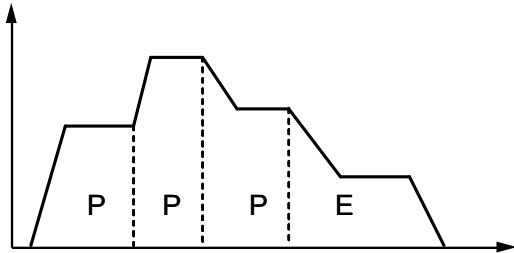

If a dwell time of 0 is set for E-point control, i.e., the end point of positioning control, the unit processes E-point control as P-point control, and finishes the operation after repeating the positioning control three times continuously.

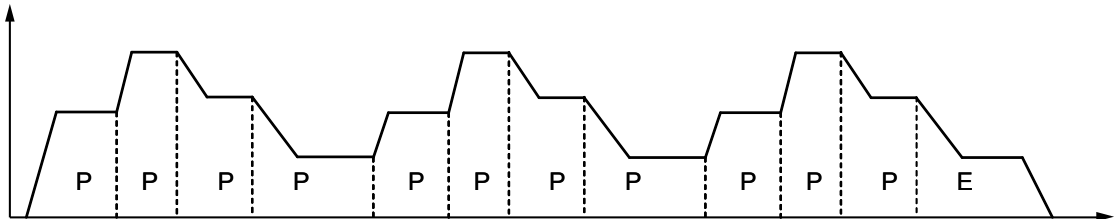

If the dwell time is set to a value other than 0 for E-point control, i.e., the end point of positioning control, FP7 MC Unit processes E-point control as C-point control, and executes the positioning control after stopping for the specified dwell time (ms). The positioning unit finishes the operation after repeating the positioning control three times.

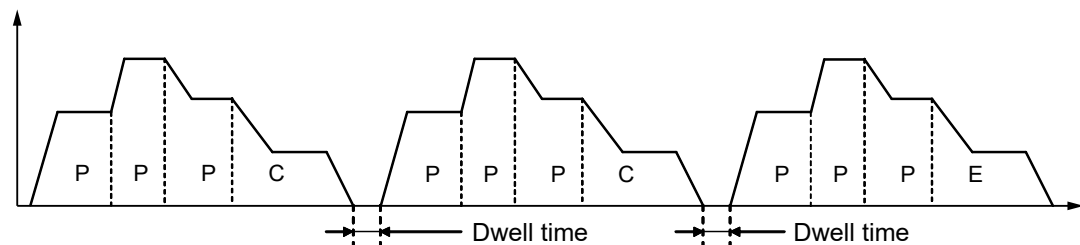

■ Setting area for positioning repeat count (Unit memories)

Axis no.	Unit memory no. (Hex)	Name	Default	Description								
Axis 1	UM 009F0	Positioning repeat count	U0	Stores the number of times for repeating the operation starting from the positioning control starting table number until the E-point. <table border="1" style="margin-left: 20px;"> <thead> <tr> <th>Value</th> <th>Operation</th> </tr> </thead> <tbody> <tr> <td>0 or 1</td> <td>Execute only once</td> </tr> <tr> <td>2-254</td> <td>Execute for a specified number of times</td> </tr> <tr> <td>255</td> <td>Execute unlimitedly until performing the stop operation</td> </tr> </tbody> </table>	Value	Operation	0 or 1	Execute only once	2-254	Execute for a specified number of times	255	Execute unlimitedly until performing the stop operation
Value	Operation											
0 or 1	Execute only once											
2-254	Execute for a specified number of times											
255	Execute unlimitedly until performing the stop operation											
Axis 2	UM 009F1											
:	:											
Axis 64	UM 00A2F											
Virtual axis 1	UM 00A30											
:	:											
Virtual axis 32	UM 00A4F											

(Note 1): As for the unit memories in which “positioning repeat count” is set, 1-word area is allocated for each axis.

8.3.2 Stop Operation During Repeat Operation

The unit operates as follows when the deceleration stop is executed during the repeat operation.

■ When repeating E-point control

When the unit detects a deceleration stop, FP7 MC Unit stops the operation after repeating the positioning control N+3 times.

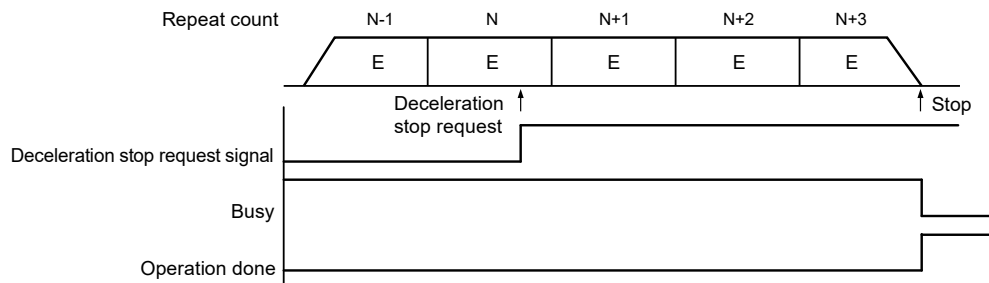

(Note): The above figure shows the case that the dwell time is 0 ms.

■ When executing multiple positioning tables continuously

When FP7 MC Unit detects a deceleration stop, it stops the operation after repeating the positioning control N+2 times (when the number of tables is 2) or N+1 times (when the number of tables is 3 or more).

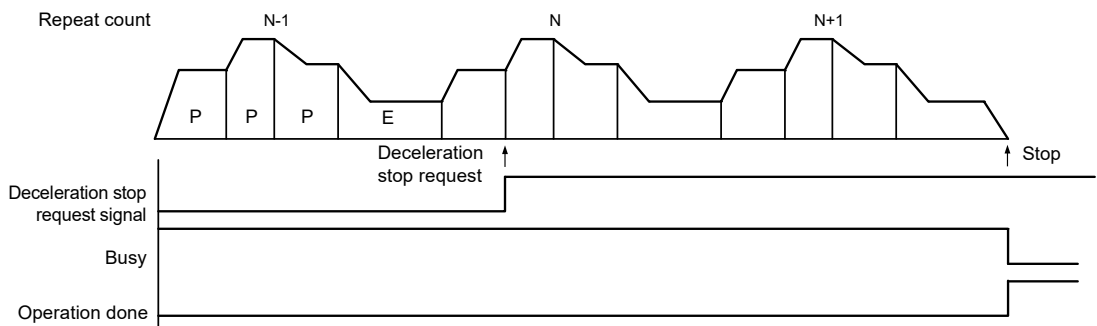

### 8.3.3 Setting and Operation of Repeat

In the following example, the positioning control with three tables (P + P + E points) is repeated three times by a single axis control.

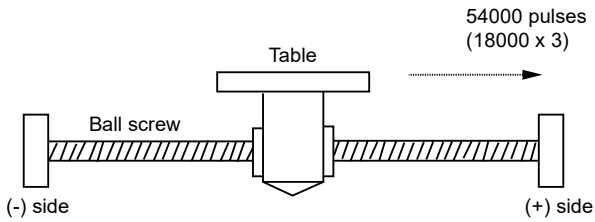

#### ■ Settings

Item	Setting example		
	Table 1	Table 2	Table 3
Operation pattern	P: Pass point	P: Pass point	E: End point
Control method	I: Increment	I: Increment	I: Increment
1st axis (L) movement amount	5000 pulses	10000 pulses	3000 pulses
Acceleration/deceleration type	L: Linear	L: Linear	L: Linear
Acceleration time (ms)	100 ms	200 ms	30 ms
Deceleration time (ms)	10 ms	20 ms	150 ms
Target speed	10000 pps	20000 pps	5000 pps
Dwell time	0 ms	0 ms	0 ms
Positioning repeat count	3 (Write in the setting area of unit memories.)		

(Note 1): The (L) in the above table is an axis number.

### ■ Operation diagram

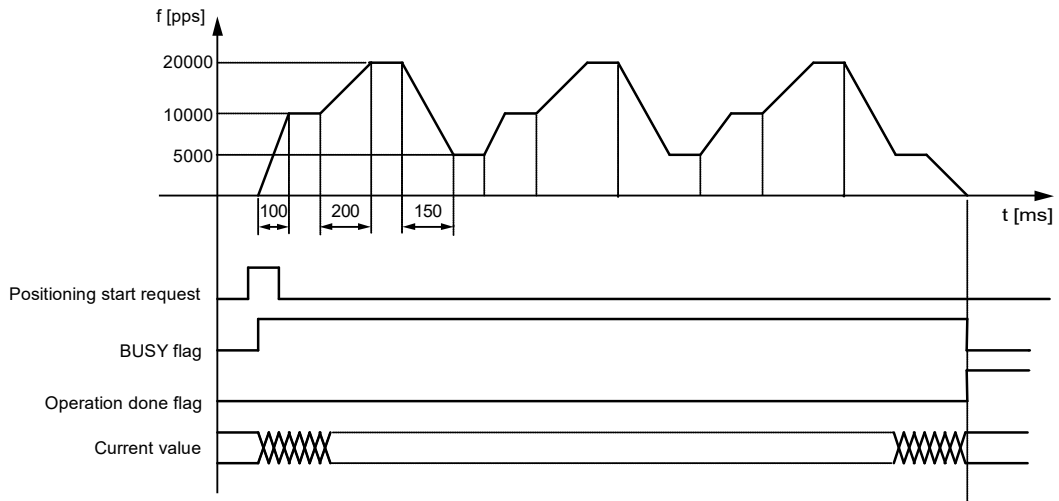

(Note): The above figure shows the case that the dwell time is 0.

### ■ Operation of input control/output control signals

- When a positioning start request (corresponding bit allocated to UM00192 to UM00197) turns on by a user program, the positioning control will start. The positioning start request will be enabled at the edge where it turns on.
- A busy flag (corresponding bit allocated to UM00090 to UM00095), which indicates that a motor is running, will turn on when the positioning control starts, and it will turn off when the operation completes.
- An operation done flag (corresponding bit allocated to UM00096 to UM0009B), which indicates the completion of operation, will turn on when the current operation is completed, and it will be held until the next positioning control, JOG operation, or home return starts.

## 8.4 Target Speed Change Function

### 8.4.1 Description of Functions

The target speed change function is used to change the target speed on an active positioning table to an arbitrary speed. Even when the speed changes, the operation amount in the table does not change. This function is available since FP7 MC Unit Ver.1.2.

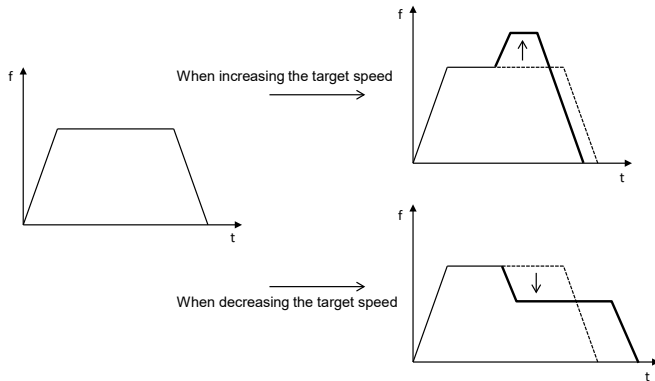

#### ■ Conditions of use

●: Available, -: Not available

Position control	Control method	Single axis control	●	In the case of the synchronous control, the speed can be changed only for the master axis. (Slave axes operate according to the master axis.)
		Interpolation control	-	
		Synchronous control	●	
	Operation pattern	E-point	●	- The speed can be changed more than once in one table. - The speed cannot be changed during the deceleration in accordance with the stop operation. - The speed cannot be changed during the deceleration in the C-point control. - The speed cannot be changed during the dwell time in the C-point control. - For the J-point control, use "J-point speed change contact" to change the speed.
		P-point	●	
		C-point	●	
		J-point	-	
Repeat control	●			
JOG Operation		-	- For the JOG operation, change "JOG operation target speed" directly to change the speed.	
Home Return		-		

#### ■ Speed change method

Speed direct specification	This is a method in which a desired speed is specified directly and the change is requested by I/O. The valid range of the function can be selected from two patterns, which are "Active table only" and "Active table to completion of operation".
Ratio specification (Override)	This is a function to change a set speed using a specified ratio (%). The change request by I/O is not necessary, and the change is reflected when the set value (ratio) is changed. The function is valid for all the positioning operations after the set timing. The ratio specification also becomes valid when the speed is changed by the speed direct specification.

## 8.4.2 Setting Procedures and Operations (Speed Direct Specification Method)

### ■ Setting procedures and operations of speed direct specification method

The target speed change function in the speed direct specification method is activated by the following procedure during a positioning operation.

1. "Change mode selection" and "Change speed" in the unit memory are set.
  2. The "Speed change request" turns on during positioning operation.
- \* "Speed change reception annunciation" turns on when the speed change is actually started.
  - \* Once the "Speed change request" turns off, the "Speed change reception annunciation" also turns off.

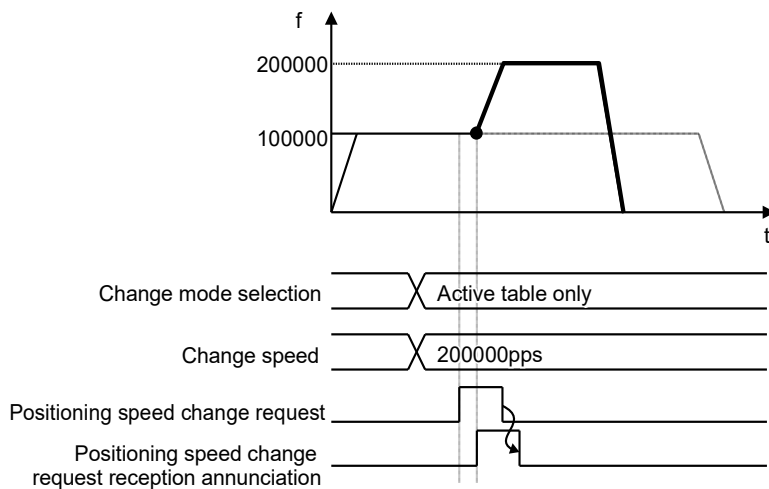

(Note 1): The acceleration time to the change speed and the deceleration time from the change speed follow the setting values of the active table.

(Note 2): The movement amount does not change when the speed change is performed.

■ **Setting parameters of speed direct specification method**

The following parameters are used in the target speed change function of the speed direction specification method.

**Positioning operation change setting area**

Axis no.	Unit memory no. (Hex)	Name	Default	Description
Axis 1	UM 66941	Positioning speed change function change mode selection	H0	Area for setting the range of the positioning speed change. 00H: Active table only 01H: Active table to E-point (until the completion of the operation) When setting any other values, the unit operates as the setting of 00H (Active table only).
Axis 2	UM 66951			
:	:			
Virtual axis 1	UM 66D41			
:	:			
Virtual axis 32	UM 66F31			
Axis 1	UM 66942 - UM 66943	Positioning speed change function speed value	U100	Area for setting a change speed for changing the positioning speed. Set using unit system conversion values. Range: 1 to 2,147,483,647 Any other settings will be errors. The ranges vary depending on the unit settings as below. Pulse: 1 to 2,147,483,647 pps µm: 1 to 2,147,483,647 µm/s inch: 0.001 to 2,147,483.647 inch/s degree: 0.001 to 2,147,483.647 rev/s
Axis 2	UM 66952 - UM 66953			
:	:			
Virtual axis 1	UM 66D42 - UM 66D43			
:	:			
Virtual axis 32	UM 66F32 - UM 66F33			



■ Example of operation (1) Speed direct specification, Active table only

Parameter	Setting value
Change mode selection	0000H (Active table only)
Change speed	150,000 (pps)

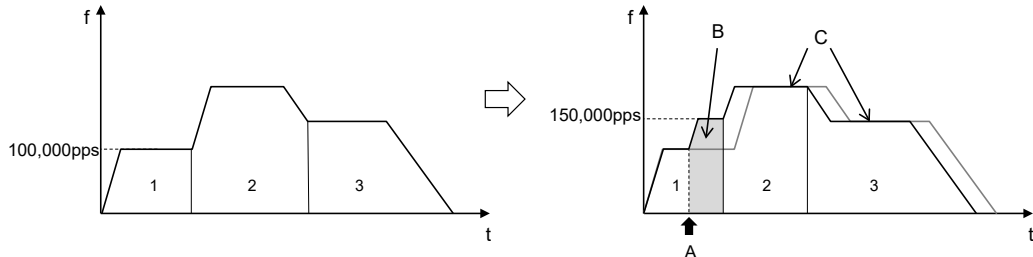

A	Speed change request turns on.
B	Only the speed of the table 1 is changed to 150,000 pps.
C	The speeds of the table 2 and 3 do not change.

■ Example of operation (2) Speed direct specification, Active table to E-point table (until the completion of the operation)

Parameter	Setting value
Change mode selection	0001H (Active table to E-point table)
Change speed	150,000 (pps)

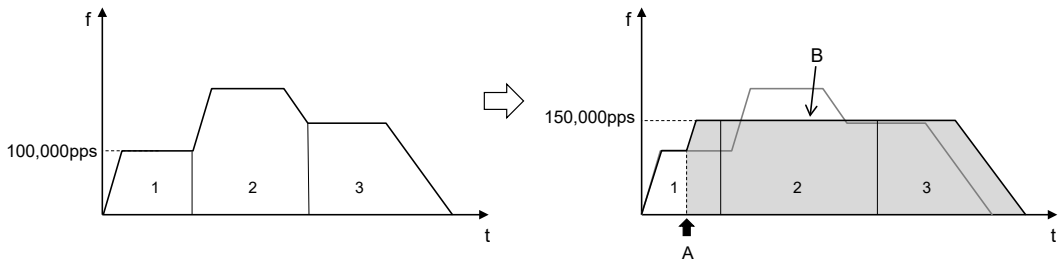

A	Speed change request turns on.
B	The speeds of all consecutive tables are changed to 150,000 pps.

**Example of operation (For repetitive operations)**

When the speed change (speed direct specification, active table only) is performed during the positioning repeat operation, only the speed of the active table in an active repeat period is changed.

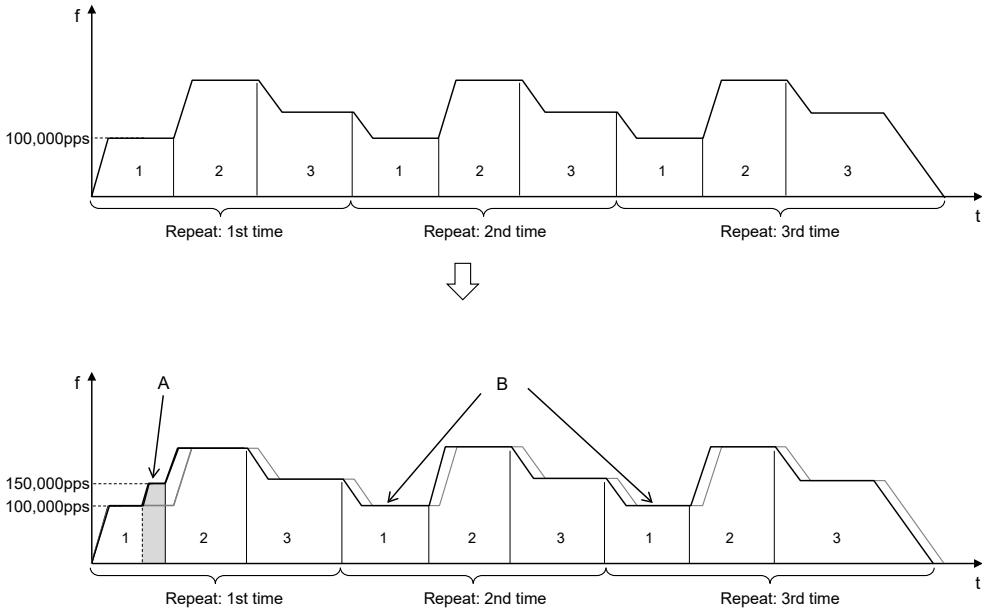

A	Only the speed of the table 1 in the first repeat period is changed to 150,000 pps.
B	The speeds of the table 1 in the second and third repeat periods are not changed.

**Notes on the speed direct specification method**

A speed can be changed during the positioning operation; however it cannot be changed during deceleration.

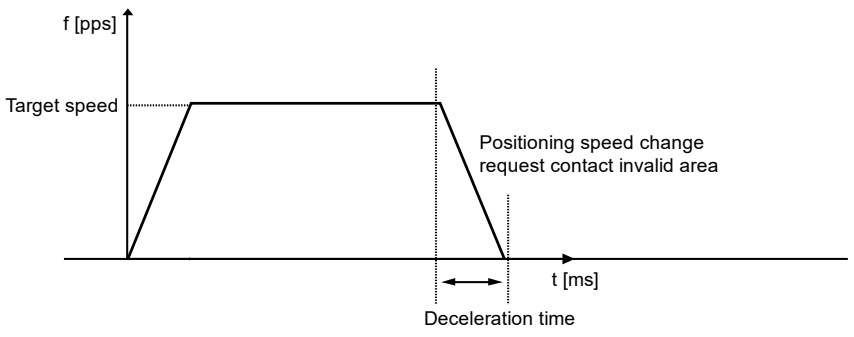

### 8.4.3 Setting Procedures and Operations (Ratio Specification Method)

#### ■ Setting procedures and operations of ratio specification method (Override)

When setting the ratio specification, the command speed is immediately reflected in the specified ratio once the "Ratio specification" in the unit memory is changed.

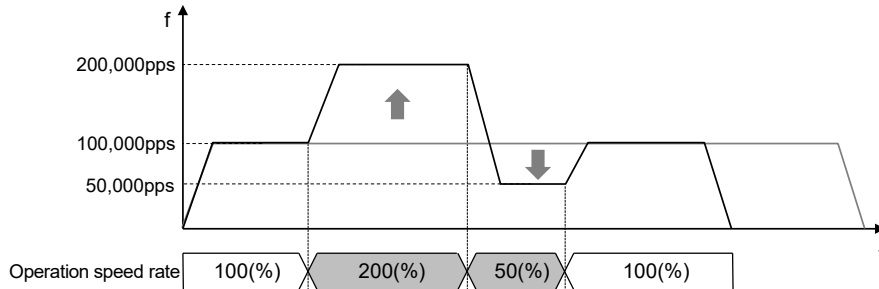

(Note 1): The acceleration time to the change speed and the deceleration time from the change speed follow the setting values of the active table.

(Note 2): The movement amount does not change when the speed change is performed.

#### ■ Setting parameters of ratio specification method

The following parameters are used in the target speed change function of the ratio specification method.

##### Positioning operation change setting area

Axis no.	Unit memory no. (Hex)	Name	Default	Description
Axis 1	UM 00380	Operation speed rate	U100	All operations relating to axes (positioning, JOG operation, home return) can be performed at the specified rate. Range: 0 to 500 (%) (For single axis control) 0 to 200 (%) (For interpolation control)
Axis 2	UM 00381			
:	:			
Virtual axis 1	UM 003C0			
Virtual axis 32	UM 003DF			

### 8.4.4 Sample Program (Target Speed Change)

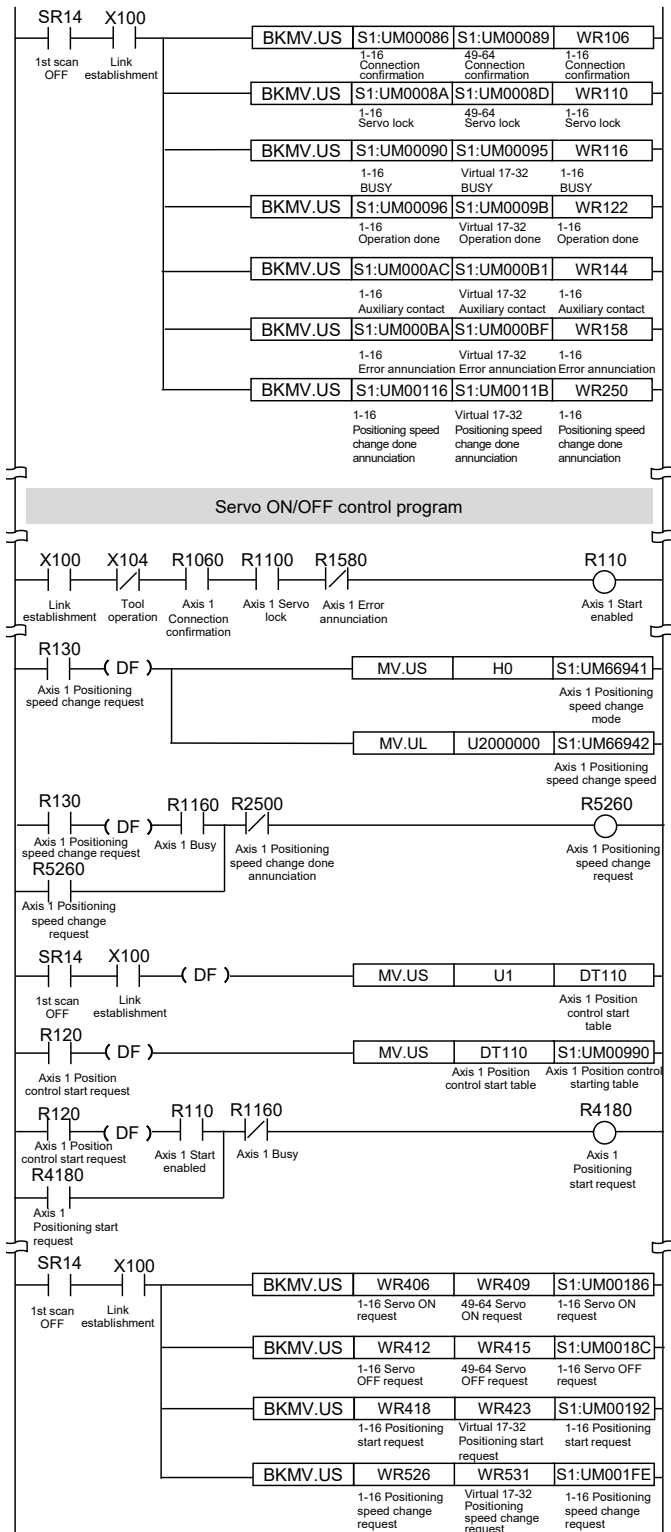

## 8.5 Movement Amount Change Function

### 8.5.1 Description of Functions

The movement amount change function is used to change the movement amount on an active positioning table to an arbitrary amount. Even when the movement amount is changed, the target speed is the same. This function is available since FP7 MC Unit Ver. 1.2.

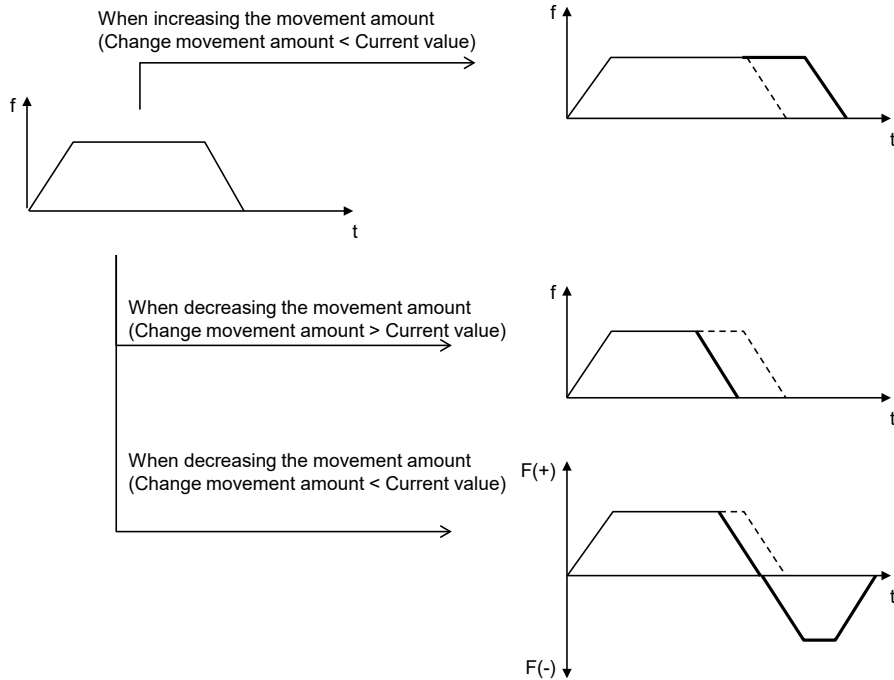

#### ■ Conditions of Use

●: Available, -: Not available

Control method	Single axis control	●	- In the case of the synchronous control, the movement amount can be changed only for the master axis. (Slave axes operate according to the master axis.)
	Interpolation control	-	
	Synchronous control	●	
Operation pattern	E-point	●	- The movement amount can be changed more than once in one table.
	P-point	●	- The movement amount cannot be changed during the deceleration in accordance with the stop operation.
	C-point	●	- The movement amount cannot be changed during the deceleration in the C-point control.
	J-point	-	
	Repeat control	●	- The movement amount cannot be changed during the dwell time in the C-point control.

## 8.5.2 Setting Procedures and Operations

### ■ Setting procedures and operations of movement amount change function

The movement amount change function is activated by the following procedure during a positioning operation.

1. "Change movement amount" in the unit memory is set.
  2. The "Movement amount change request" turns on during positioning operation.
- \* "Movement amount change reception annunciation" turns on when the movement amount change is actually started.
- \* Once the "Speed change request" turns off, the "Speed change reception annunciation" also turns off.

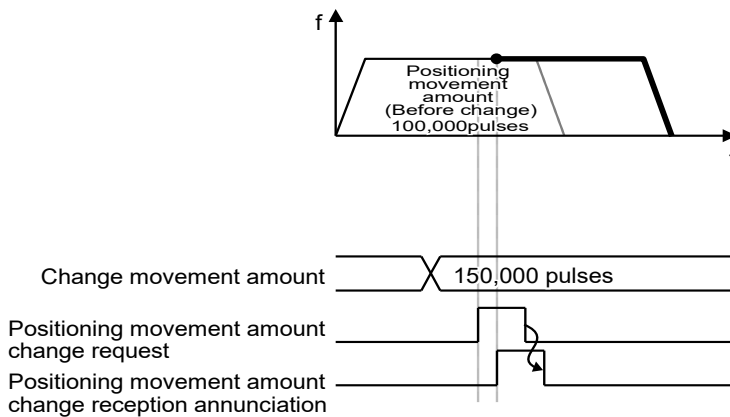

### ■ Setting parameter

The following parameters are used in the movement amount change function.

#### Positioning operation change setting area

Axis no.	Unit memory no. (Hex)	Name	Default	Description
Axis 1	UM 6694A - UM 6694B	Positioning movement amount change function movement amount	H0	Area for setting a change movement amount for changing the positioning movement amount. Range: -1,073,741,823 to 1,073,741,823 (command unit system)
Axis 2	UM 6695A - UM 6695B			
:	:			
Virtual axis 1	UM 66D4A - UM 66D4B			
:	:			
Virtual axis 32	UM 66F3A - UM 66F3B			

■ Example of operation (1) When reducing the movement amount (Change movement amount > Current movement amount)

Parameter	Setting value
Control method	Increment
Positioning movement amount (Before change)	10,000 pulses
Positioning movement amount (After change)	7,000 pulses

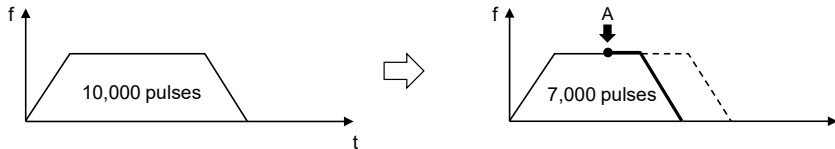

A	Movement amount change request on
---	-----------------------------------

■ Example of operation (2) When reducing the movement amount (Change movement amount < Current movement amount)

Parameter	Setting value
Control method	Increment
Positioning movement amount (Before change)	10,000 pulses
Positioning movement amount (After change)	1,000 pulses

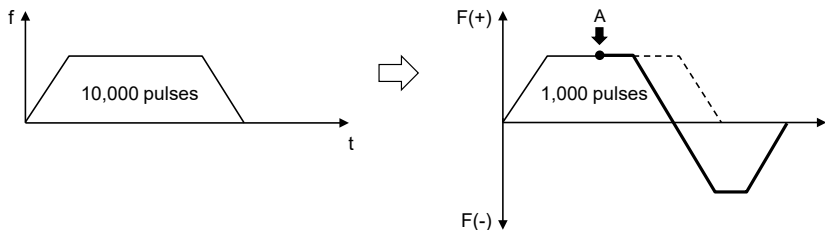

A	Movement amount change request on
---	-----------------------------------

**■ Example of operation (3) When a continuous table operation is performed (Increment)**

Parameter	Setting value
Control method	Increment
First table positioning movement amount (Before change)	5,000 pulses
First table positioning movement amount (After change)	8,000 pulses

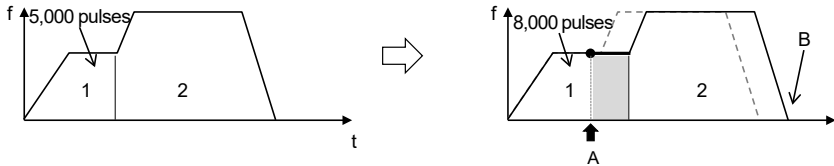

A	Movement amount change request on
B	Because of the increment setting, the stop position of the table 2 also changes.

**■ Example of operation (4) When a continuous table operation is performed (Absolute)**

Parameter	Setting value
Control method	Absolute
First table positioning movement amount (Before change)	5,000 pulses
First table positioning movement amount (After change)	8,000 pulses

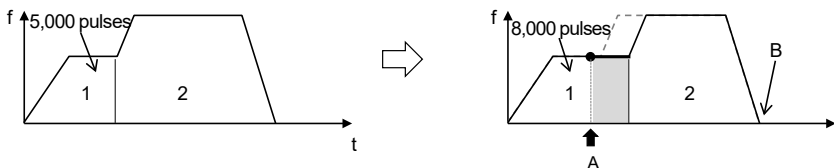

A	Movement amount change request on
B	Because of the absolute setting, the stop position of the table 2 does not change.



### ■ Example of operation (For repetitive operations)

When the movement amount change is performed during the positioning repeat operation, only the movement amount of the active table in an active repeat period is changed.

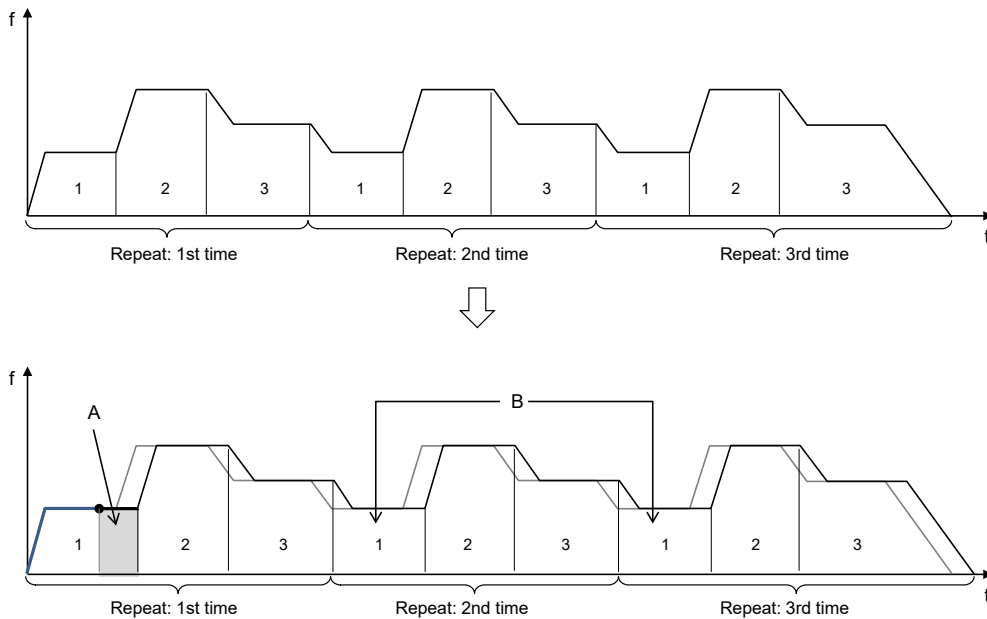

A	Only the movement amount of the table 1 in the first repeat period is changed to 8,000 pulses.
B	The movement amounts of the table 1 in the second and third repeat periods are not changed.

### ■ Auxiliary output when changing movement amounts

Even if the movement amount is changed when the auxiliary output is set in the delay mode, the auxiliary contact turns on at the position of the delay ratio to the movement amount before the change. If the delay ratio is set to 100%, however, the auxiliary contact turns on the completion of the operation.

### 8.5.3 Sample Program

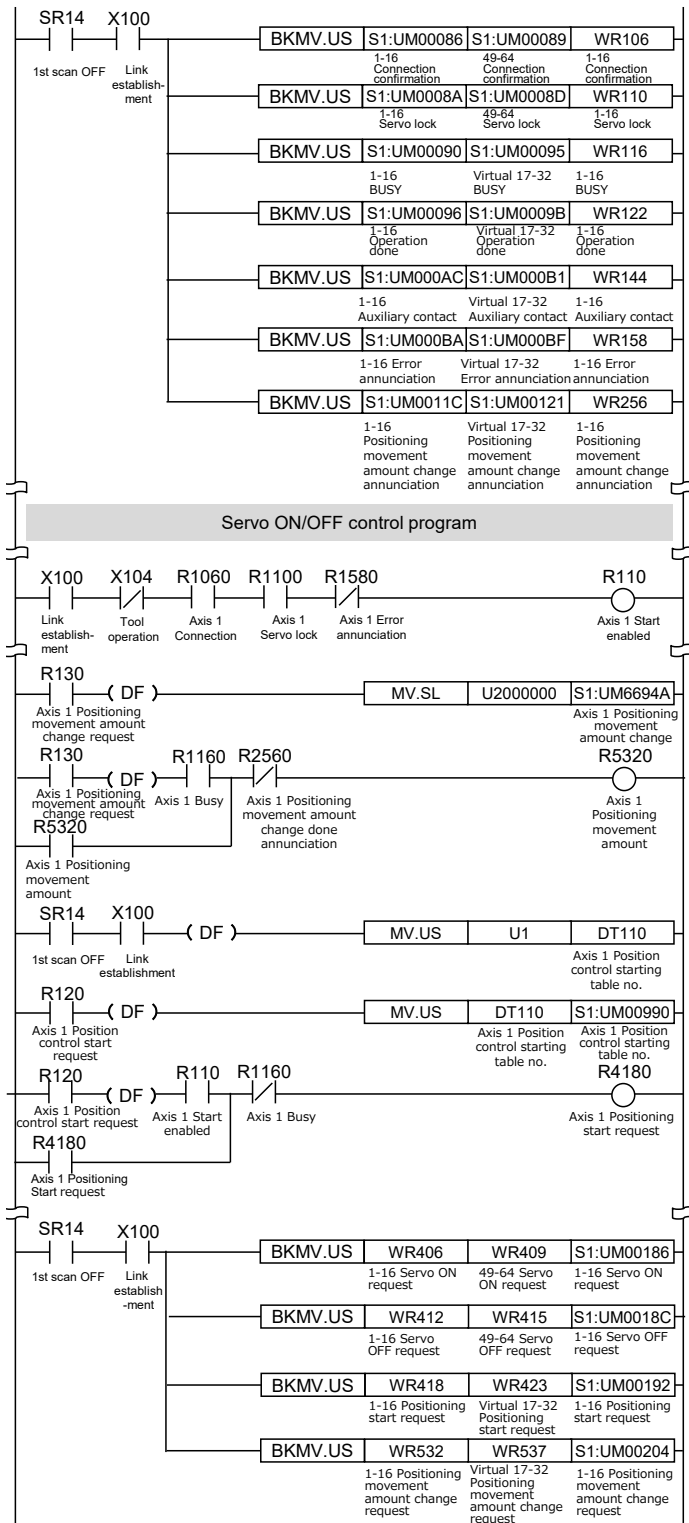

## 8.6 Dwell Time

The time taken until the next operation after the completion of an executed positioning table in the automatic operation is called dwell time.

### ■ For E-point control

The dwell time is the time taken from the completion of the position command until the operation done flag turns on.

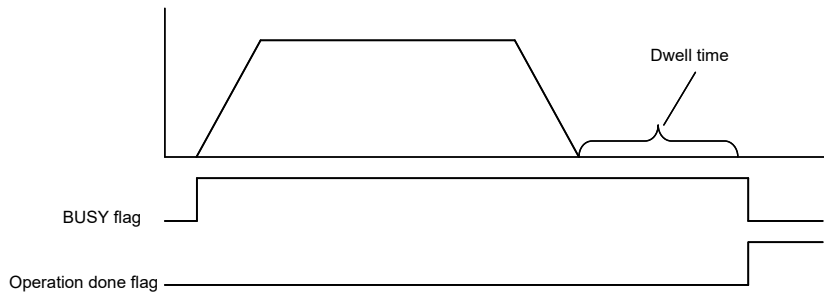

### ■ For P-point control

In the P-point control, the positioning table operates consecutively, therefore, the dwell time is ignored. For the last table (E-point), as well as the E-point control, the dwell time is the time taken from the completion of the position command until the operation done flag turns on.

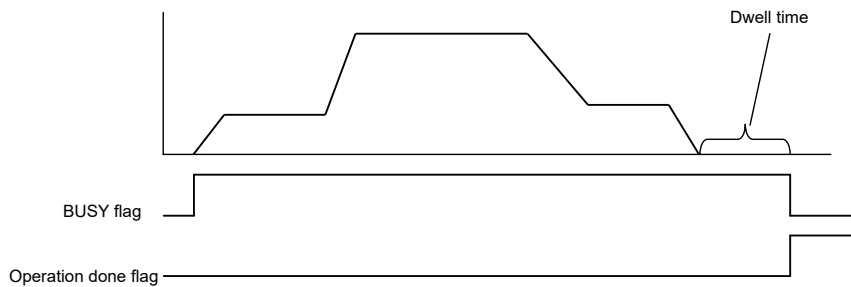

### ■ For C-point control

The dwell time is the waiting time for executing the next table from the completion of the positioning table (deceleration stop). For the last table (E-point), as well as the E-point control, the dwell time is the time taken from the completion of the position command until the operation done flag turns on.

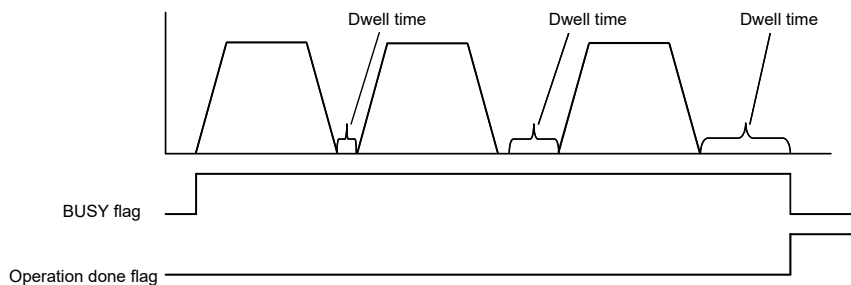

## 8.7 Auxiliary Output Code and Auxiliary Output Contact

---

- The auxiliary output contact is a function to inform about which table's operation is performing when the automatic operation (E-point control, C-point control, P-point control, J-point control) is executed.
- The auxiliary output contact and the auxiliary output code can be used by setting the parameter "auxiliary output mode" of each axis to the With or Delay mode.

### ■ Auxiliary output contact

The With mode and Delay mode are available for the operations of auxiliary output contacts.

Auxiliary output mode	Operation
With mode	At the same time that the automatic operation starts, the auxiliary contact flag of a corresponding axis allocated to the I/O area turns on.
Delay mode	The auxiliary contact flag of a corresponding axis allocated to the I/O area turns on according to the ratio (%) of the positioning movement amount of automatic operation. The setting of the ratio of turning on the flag in the delay mode is set in the auxiliary output delay ratio area in the unit memories. However, when the automatic operation is set to the J-point control, the operation is the same as that in the "With mode".

Also, the ON time of an auxiliary contact flag can be specified in the ms unit.



### ◆ NOTES

---

In the case of the J-point control, the operation in the "Delay mode" is the same as that in the "With mode".

■ **Auxiliary output code**

- The auxiliary output code (1 word) can be set for each table of the positioning data. The content of the process currently carried out can be confirmed by setting the auxiliary output code.
- The values in the auxiliary output code are held until the next positioning table is executed. Also, the auxiliary output code that was output just before the completion of the automatic operation is held.

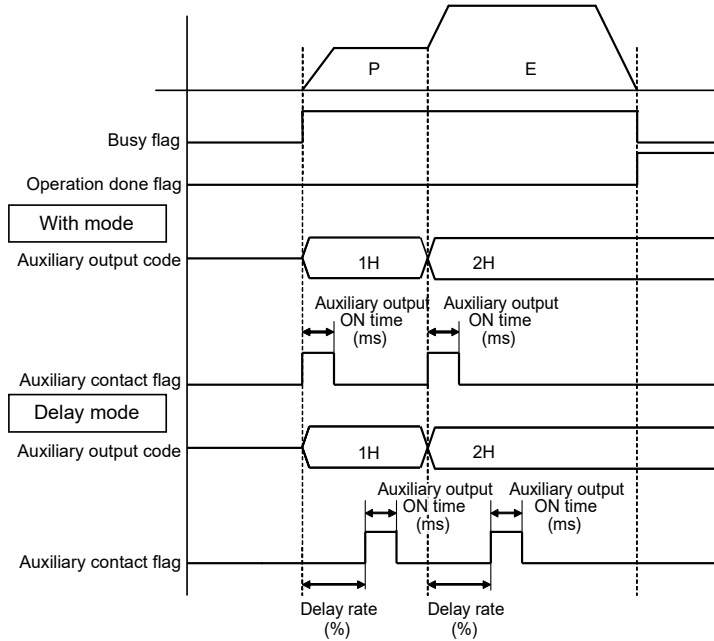

◆ **NOTES**

Auxiliary output code is stored at the same time that the positioning operation starts regardless of the type of the auxiliary output mode (With mode or Delay mode).

## 8.8 Sample Programs

### 8.8.1 Sample Programs (E-point, P-point and C-point Controls)

The operation for starting the positioning operation is mainly divided into five steps on a user program.

- Read flags stored in the unit memories (input control area).
- Control the Servo ON/OFF.
- Check the condition if the control of each axis can be started.
- Set positioning table numbers, check the conditions, and start the positioning operation.
- Write operation results in the unit memories (output control area).

(Note): The sample program on the next page is for activating the positioning operation with the table number 1 of the axis number 1 for the FP7 MC Unit installed in the slot number 1. To simplify the explanation, the part related to the positioning operation is extracted.

#### ■ Contents of sample program

Mark	Description
①	Read flags indicating states from the input control area of the unit memories (UM) to arbitrary areas (WR). Read flags such as connection confirmation flag, servo lock flag, busy flag, and error annunciation flag.
②	Servo ON/OFF control program
③	Check required conditions and replace it with the start enabled flag (R110) in the program.
④	Positioning operation start program
	① (a) Set the repeat count as necessary.
	① (b) Specify positioning table numbers.
① (c) Start the positioning operation.	
⑤	Write flags to the output control area of the unit memories (UM) from arbitrary area (WR) where the start conditions are written. Start the positioning operation.

■ Sample program

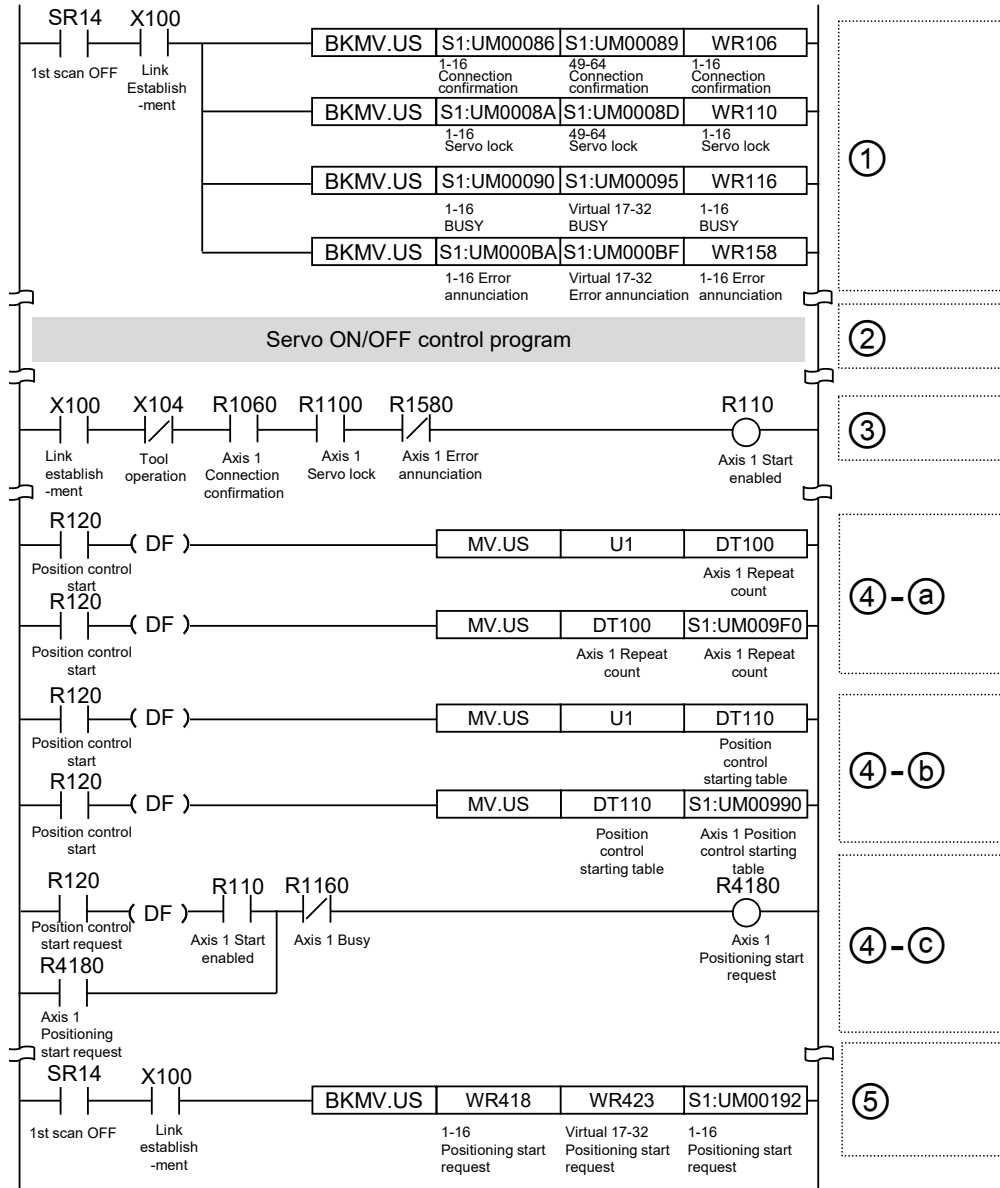

## 8.8.2 Precautions on Programming

---

### ■ Precautions on programming

- If any value such as a movement amount, acceleration time, deceleration time or target speed is out of the specified range, a setting value error will occur when the position control starts.
- Unit memory numbers allocated to flags and start requests vary depending on axis numbers.
- A specified slot number varies depending on the installation position of FP7 MC Unit.

### ■ Operation at over limit input (Limit is Enabled)

Condition	Direction	Limit status	Operation
When each control starts	Forward	Over limit input (+): ON	Not executable, Error occurs.
		Over limit input (-): ON	Not executable, Error occurs.
	Reverse	Over limit input (+): ON	Not executable, Error occurs.
		Over limit input (-): ON	Not executable, Error occurs.
When each control is performed	Forward	Over limit input (+): ON	Deceleration stop, Limit error occurs.
	Reverse	Over limit input (-): ON	Deceleration stop, Limit error occurs.



## 8.9 Reconstruction of Positioning Data by User Programs

---

### 8.9.1 Reconstruction of Positioning Data

---

- Positioning data (standard area [1,000 tables]) set by CMI is downloaded to the FROM of FP7 MC Unit.
- The positioning data stored in the FROM is transferred to the system area of FP7 MC Unit when the power is turned on. The system area cannot be directly accessed using user programs.
- When positioning data (such as movement amount or target speed) varies according to operation results, the positioning data should be rewritten using user programs.
- In the system area of FP7 MC Unit, the positioning data for 32 words x 1000 tables x 96 axes (64 real axes + 32 virtual axes) are stored.
- When rewriting positioning data using user programs, the data is read and written from/to the system area through the 24 buffer areas allocated to the unit memories.
- The data that can be read or written in a single operation using a user program is data for 32 words x Max. 500 tables x 1 axis.

### 8.9.2 Procedure of Rewriting Positioning Data

The following flowchart shows the flow of the operation required in a user program.

- For reading and writing, the operations to be executed (read, write) and targets (axis number, table number, table size) are specified in the buffer control area of the unit memories.
- By executing “Recalculation” after the operation, the positioning data stored in the system area of FP7 MC Unit is updated. Once the "Recalculation" is completed, the positioning operation can be started for the rewritten positioning data.

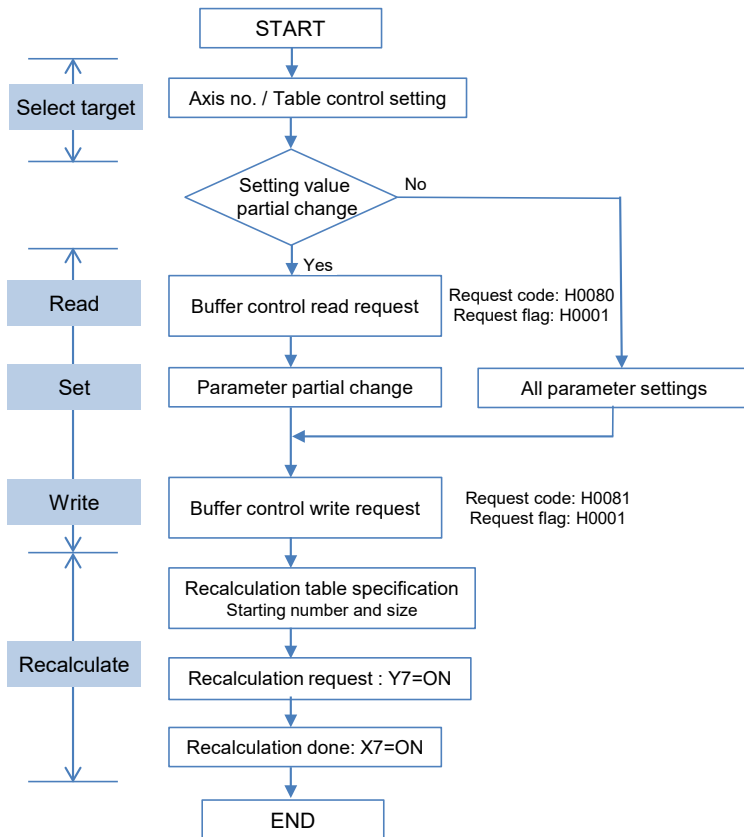

### ■ Recalculation

Recalculation is necessary after rewriting positioning data using user programs. The procedure of recalculation is as follows. When recalculation is not performed, the operation is executed with the positioning table before rewriting.

1. Change the positioning table in the unit memories.
2. Turn on the recalculation request (Y7) in the I/O area.
3. Confirm that the recalculation done flag (X7) in the I/O area is on. (Confirm that the recalculation process is completed.)

(Note): I/O numbers of the recalculation request (Y7) and recalculation done flag (X7) vary according to the value of the "Starting word number" allocated to FP7 MC Unit.

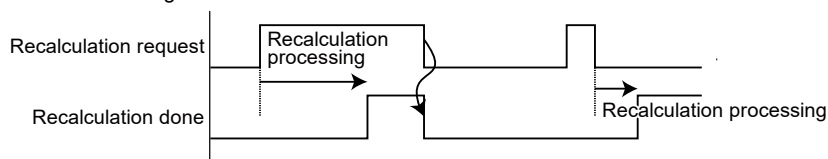

The recalculation done flag turns on when the recalculation by the recalculation request is completed. After that, the recalculation done flag turns off when the recalculation request signal turns off.



### ◆ REFERENCE

For details of the areas used for rewriting positioning data, refer to "16.7.4.1 Control Area for Buffer Control" and "16.7.4.2 Positioning Data Setting Area".

For details of the area used for the recalculation process, refer to "16.5.2 Setting Parameter Control Area".

The units used for the recalculation process are as follows.

#### Setting parameter control area

Unit memory no. (Hex)	Name	Default	Description
UM 00284	Recalculation starting table number	U1	This is used to rewrite positioning data using a user program. Reconstructs the positioning data which starts with the table number specified in this area when the recalculation request (Y7) turns on. Range: 1 to 1000
UM 00285	Recalculation starting table size	U1	Reconstructs the positioning data of the table size specified in this area when the recalculation request (Y7) turns on. Range: 1 to 500

The unit memories used for rewriting positioning data is as follows.

**Buffer control area for positioning data**

Unit memory no. (Hex)	Name	Default	Description						
UM 06240	Request flag control	H0	Write data to this area for sending/receiving data of buffers for positioning data. After the completion of the execution, it is rewritten to H0 by FP7 MC Unit. H0000: Not request H0001: Request Any other settings will be errors.						
UM 06241	Request code control	H0	Set the request code of data control of buffer for positioning data. H0080: Read request H0081: Write request Any other settings will be errors.						
UM 06242	Response code control	H0	Stores the response code for the request of the buffer for positioning data. H0000: Complete H0001: During processing HFF00: Setting value error						
UM 06243	Axis number control	U1	Specify the axis number of positioning data to be transferred. <table border="1"> <thead> <tr> <th>Range</th> <th>Corresponding axis no.</th> </tr> </thead> <tbody> <tr> <td>1 to 64</td> <td>Corresponds to the existing axes 1 to 64.</td> </tr> <tr> <td>65 to 96</td> <td>Corresponds to the virtual axes 1 to 32.</td> </tr> </tbody> </table> Any other settings will be errors.	Range	Corresponding axis no.	1 to 64	Corresponds to the existing axes 1 to 64.	65 to 96	Corresponds to the virtual axes 1 to 32.
Range	Corresponding axis no.								
1 to 64	Corresponds to the existing axes 1 to 64.								
65 to 96	Corresponds to the virtual axes 1 to 32.								
UM 06244	Start table number	U1	Specify the starting table number of positioning data to be transferred. Range: 1 to 1000 Any other settings will be errors.						
UM 06245	Table size	U1	Specify the table size of positioning data to be transferred. Range: 1 to 500 Any other settings will be errors.						
UM 06246	Extended positioning table usage setting	U0	Set whether to use the extended positioning table or not. <table border="1"> <thead> <tr> <th>bit</th> <th>Name</th> <th>Description</th> </tr> </thead> <tbody> <tr> <td>15-0</td> <td>Extended positioning table usage setting</td> <td>0: Not make the table setting 1: Make the table setting Any other settings will be errors.</td> </tr> </tbody> </table> * When using the extended positioning table; table nos. 401 to 500 is used as extended table nos. 10,001 to 10,100.	bit	Name	Description	15-0	Extended positioning table usage setting	0: Not make the table setting 1: Make the table setting Any other settings will be errors.
bit	Name	Description							
15-0	Extended positioning table usage setting	0: Not make the table setting 1: Make the table setting Any other settings will be errors.							
UM 06247	Extended positioning table usage setting corresponding axis no.	U0	Set transfer axis numbers of positioning data. <table border="1"> <thead> <tr> <th>Range</th> <th>Corresponding axis no.</th> </tr> </thead> <tbody> <tr> <td>1 to 64</td> <td>Corresponds to the existing axes 1 to 64.</td> </tr> <tr> <td>65 to 96</td> <td>Corresponds to the virtual axes 1 to 32.</td> </tr> </tbody> </table> Any other settings will be errors.	Range	Corresponding axis no.	1 to 64	Corresponds to the existing axes 1 to 64.	65 to 96	Corresponds to the virtual axes 1 to 32.
Range	Corresponding axis no.								
1 to 64	Corresponds to the existing axes 1 to 64.								
65 to 96	Corresponds to the virtual axes 1 to 32.								

## Positioning data setting area

Unit memory no. (Hex)	Name	Default	Description												
UM 06248	Control code	H0	<p>Set the position setting mode and acceleration/deceleration pattern for the positioning operation.</p> <table border="1"> <thead> <tr> <th>bit</th> <th>Name</th> <th>Description</th> </tr> </thead> <tbody> <tr> <td>0</td> <td>Control method</td> <td>0: Increment mode 1: Absolute mode</td> </tr> <tr> <td>1</td> <td>Acceleration/deceleration method</td> <td>0: Linear acceleration/deceleration 1: S-shaped acceleration/deceleration</td> </tr> <tr> <td>15-2</td> <td>—</td> <td>—</td> </tr> </tbody> </table>	bit	Name	Description	0	Control method	0: Increment mode 1: Absolute mode	1	Acceleration/deceleration method	0: Linear acceleration/deceleration 1: S-shaped acceleration/deceleration	15-2	—	—
bit	Name	Description													
0	Control method	0: Increment mode 1: Absolute mode													
1	Acceleration/deceleration method	0: Linear acceleration/deceleration 1: S-shaped acceleration/deceleration													
15-2	—	—													
UM 06249	Operation Patterns	H0	<p>Set the single and interpolation operation pattern for the positioning operation. The relation of the interpolation depends on the settings in the axis group setting area in the common area of the unit memory. In the interpolation operation, the setting for the axis with the smallest number in an axis group is effective.</p> <table border="1"> <thead> <tr> <th>bit</th> <th>Name</th> <th>Description</th> </tr> </thead> <tbody> <tr> <td>7-0</td> <td>Control pattern</td> <td>H00: E-point control (End point control) H01: P-point control (Pass point control) H02: C-point control (Continuance point control) H03: J-point control (Speed point control) Any other settings will be errors.</td> </tr> <tr> <td>15-8</td> <td>Interpolation setting</td> <td>H00: Linear interpolation (Composite speed) H01: Linear interpolation (Major axis speed) H10: Circular interpolation (Center point/CW direction) H11: Circular interpolation (Center point/CCW direction) H20: Circular interpolation (Pass point): H50: Spiral interpolation (Center point/CW direction/1st axis feed) H51: Spiral interpolation (Center point/CCW direction/1st axis feed) H52: Spiral interpolation (Center point/CW direction/2nd axis feed) H53: Spiral interpolation (Center point/CCW direction/2nd axis feed) H54: Spiral interpolation (Center point/CW direction/3rd axis feed) H55: Spiral interpolation (Center point/CCW direction/3rd axis feed) H60: Spiral interpolation (Pass point/1st axis feed) H61: Spiral interpolation (Pass point/2nd axis feed) H62: Spiral interpolation (Pass point/3rd axis feed) Any other settings will be errors.</td> </tr> </tbody> </table>	bit	Name	Description	7-0	Control pattern	H00: E-point control (End point control) H01: P-point control (Pass point control) H02: C-point control (Continuance point control) H03: J-point control (Speed point control) Any other settings will be errors.	15-8	Interpolation setting	H00: Linear interpolation (Composite speed) H01: Linear interpolation (Major axis speed) H10: Circular interpolation (Center point/CW direction) H11: Circular interpolation (Center point/CCW direction) H20: Circular interpolation (Pass point): H50: Spiral interpolation (Center point/CW direction/1st axis feed) H51: Spiral interpolation (Center point/CCW direction/1st axis feed) H52: Spiral interpolation (Center point/CW direction/2nd axis feed) H53: Spiral interpolation (Center point/CCW direction/2nd axis feed) H54: Spiral interpolation (Center point/CW direction/3rd axis feed) H55: Spiral interpolation (Center point/CCW direction/3rd axis feed) H60: Spiral interpolation (Pass point/1st axis feed) H61: Spiral interpolation (Pass point/2nd axis feed) H62: Spiral interpolation (Pass point/3rd axis feed) Any other settings will be errors.			
bit	Name	Description													
7-0	Control pattern	H00: E-point control (End point control) H01: P-point control (Pass point control) H02: C-point control (Continuance point control) H03: J-point control (Speed point control) Any other settings will be errors.													
15-8	Interpolation setting	H00: Linear interpolation (Composite speed) H01: Linear interpolation (Major axis speed) H10: Circular interpolation (Center point/CW direction) H11: Circular interpolation (Center point/CCW direction) H20: Circular interpolation (Pass point): H50: Spiral interpolation (Center point/CW direction/1st axis feed) H51: Spiral interpolation (Center point/CCW direction/1st axis feed) H52: Spiral interpolation (Center point/CW direction/2nd axis feed) H53: Spiral interpolation (Center point/CCW direction/2nd axis feed) H54: Spiral interpolation (Center point/CW direction/3rd axis feed) H55: Spiral interpolation (Center point/CCW direction/3rd axis feed) H60: Spiral interpolation (Pass point/1st axis feed) H61: Spiral interpolation (Pass point/2nd axis feed) H62: Spiral interpolation (Pass point/3rd axis feed) Any other settings will be errors.													
UM 0624A - UM 0624B	Reserved for system														
UM 0624C	Positioning acceleration time	U100	<p>Set the acceleration and deceleration time for the positioning operation.</p> <p>Range: 0 to 10,000 (ms)</p>												
UM 0624D	Positioning deceleration time	U100	<p>Any other settings will be errors. In the interpolation control, the setting for the axis with the smallest number in an axis group is effective.</p>												

## Automatic Operation (Position Control)

Unit memory no. (Hex)	Name	Default	Description
UM 0624E - UM 0624F	Positioning target speed (Interpolation speed)	U1000	<p>In case of the individual operation (no interpolation), it is the target speed of the corresponding axis. In case of the interpolation operation, it is the target speed of the interpolation. In the interpolation operation, the setting for the axis with the smallest number in an axis group is effective.</p> <p>Range: 1 to 2,147,483,647</p> <p>Any other settings will be errors.</p> <p>The ranges vary depending on the unit settings as below.</p> <p>Pulse: 1 to 2,147,483,647 pps  <math>\mu\text{m}</math>: 1 to 2,147,483,647 <math>\mu\text{m/s}</math>                      inch: 0.001 to 2,147,483.647 inch/s                      degree: 0.001 to 2,147,483.647 rev/s</p>
UM 06250 - UM 06251	Positioning movement amount	K0	<p>Set the position command value for the positioning operation. It is the movement amount in the case of increment, and coordinates in the case of absolute depending on the control code setting.</p> <p>Range: -2,147,483,648 to 2,147,483,647</p> <p>Any other settings will be errors.</p> <p>The ranges vary depending on the unit settings as below.</p> <p>pulse: -2,147,483,648 to 2,147,483,647 pulse  <math>\mu\text{m}</math> (0.1<math>\mu\text{m}</math>): -214,748,364.8 to 214,748,364.7 <math>\mu\text{m}</math>  <math>\mu\text{m}</math> (1<math>\mu\text{m}</math>): -2,147,483,648 to 2,147,483,647 <math>\mu\text{m}</math>                      inch (0.00001 inch): -21,474.83648 to 21,474.83647 inches                      inch (0.0001 inch): -214,748.3648 to 214,748.3647 inches                      degree (0.1 degree): -214,748,364.8 to 214,748,364.7 degrees                      degree (1 degree): -2,147,483,648 to 2,147,483,647 degrees</p>
UM 06252 - UM 06253	Auxiliary point	K0	<p>Set the auxiliary point (coordinate of center or pass point) in the case of circular interpolation or spiral interpolation control.</p> <p>Range: -2,147,483,648 to 2,147,483,647</p> <p>Any other settings will be errors.</p> <p>The ranges vary depending on the unit settings as below.</p> <p>pulse: -2,147,483,648 to 2,147,483,647 pulse  <math>\mu\text{m}</math> (0.1<math>\mu\text{m}</math>): -214,748,364.8 to 214,748,364.7 <math>\mu\text{m}</math>  <math>\mu\text{m}</math> (1<math>\mu\text{m}</math>): -2,147,483,648 to 2,147,483,647 <math>\mu\text{m}</math>                      inch (0.00001 inch): -21,474.83648 to 21,474.83647 inches                      inch (0.0001 inch): -214,748.3648 to 214,748.3647 inches                      degree (0.1 degree): -214,748,364.8 to 214,748,364.7 degrees                      degree (1 degree): -2,147,483,648 to 2,147,483,647 degrees</p>
UM 06254	Dwell time	U0	<p>When the positioning operation of this table is finished;</p> <p>C-point (Continuance point): The motor stops for the dwell time and the next operation is started.</p> <p>P-point (Pass point): It is ignored.</p> <p>J-point (Speed control): It is ignored.</p> <p>E-point (End point): The positioning done contact turns on after waiting for the dwell time.</p> <p>Range: 0 to 32,767 (ms)</p> <p>Any other settings will be errors.</p>

Unit memory no. (Hex)	Name	Default	Description
UM 06255	Auxiliary output code	U0	Set arbitrary data as auxiliary output codes when using the auxiliary output function.

### 8.9.3 Sample Program (Rewriting Positioning Tables)

The operation for rewriting positioning tables using a user program is mainly divided into five steps.

- Specify the axis number, table number and table size to rewrite the positioning table.
- Set the positioning data to be rewritten.
- Set the positioning data in the positioning data setting area in buffers.
- Execute reading or writing the data in accordance with the requests stored in buffers.
- Execute recalculation.

(Note): The sample program on the next page is for rewriting the positioning data of one table from the table number 1 of the axis number 1 for the FP7 MC Unit installed in the slot number 1.

#### ■ Contents of sample program

Mark	Description	
①	Set the axis number, table number and table size to be rewritten.	
	(a)	Set the axis number, table number and table size.
	(b)	Set the axis number, table number and table size in the unit memory (control area for buffer control).
②	Set the positioning data (14 words) to be rewritten in an arbitrary area.	
③	Set the positioning data in the unit memory (positioning data setting area in the buffer).	
④	Execute reading and writing the data in accordance with the requests stored in the buffer.	
	(a)	Specify reading or writing in the unit memory (control area for buffer control).
	(b)	Set request flags in the unit memory (control area for buffer control).
⑤	Execute recalculation.	
	(a)	Set the table number and table size to be recalculated in the unit memory (setting parameter control area).
	(b)	Request recalculation until it is completes.
	(c)	Reset the recalculation table size stored in the unit memory (setting parameter control area) to zero.



■ Program example

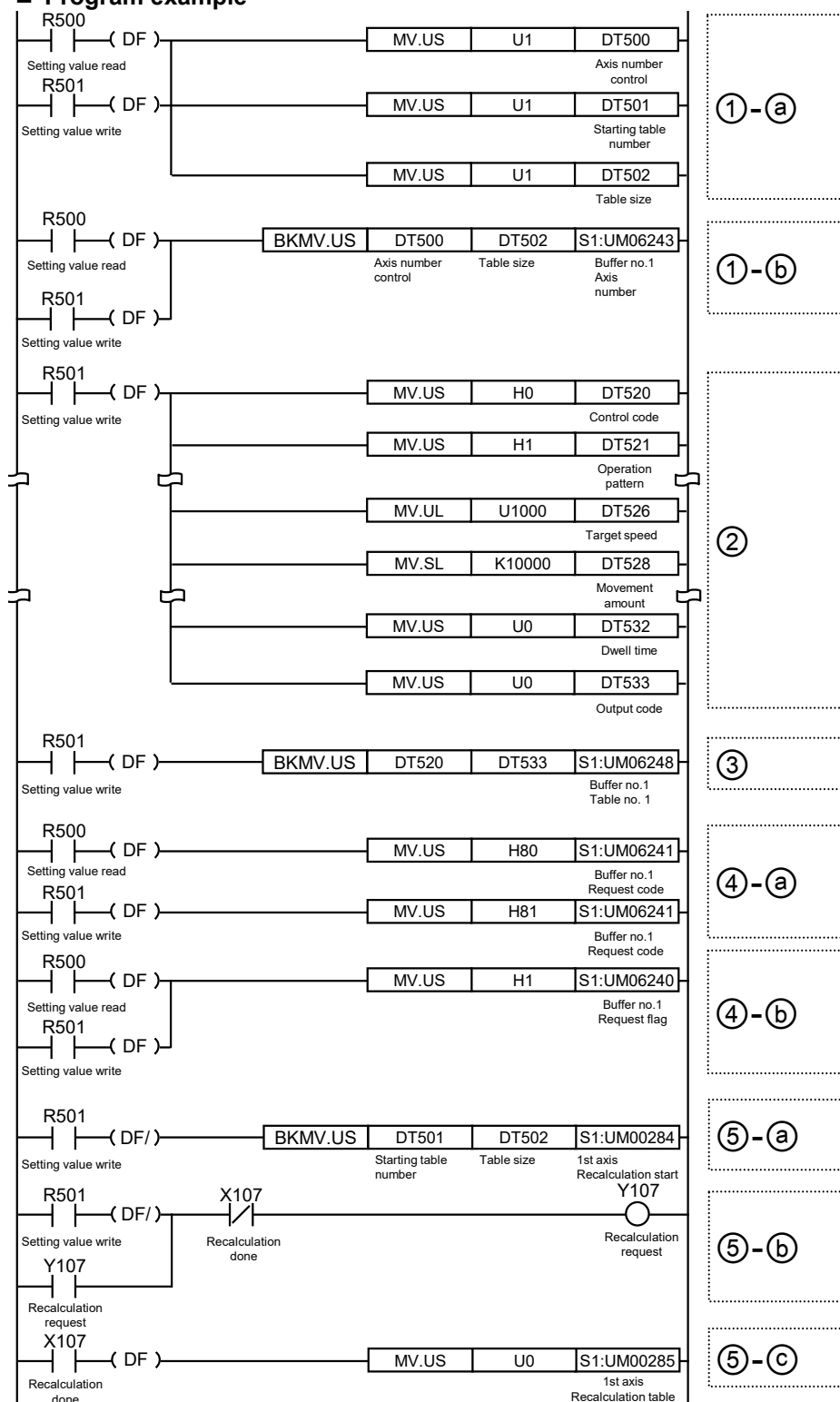

## 8.10 Use of Extended Positioning Table

### 8.10.1 Use of Extended Positioning Table

There are a standard area and an expansion area in the positioning data setting area, and they have the following characteristics. Use them in accordance with the intended use.

Item	Standard area	Extended area
No. of positioning data tables	1000 tables	100 tables
Table no.	1 to 1000	10001 to 10100
Positioning data setting by Control Motion Integrator	Available	Impossible settings
Positioning data setting by user programs	Available This setting is not reflected unless the recalculation request is made after writing data to the unit memory by a user program.	Available The operation can be started after writing data to the unit memory by a user program. There is no need to request the recalculation.
Characteristics	When setting positioning data in advance by Control Motion Integrator, the start time of an operation is shorter than that when using the extended area.	When setting positioning data by user programs, the start time of a request is shorter than that when using the extended area. However, as the recalculation is performed after starting the request, the starting time of the operation is a little bit longer.
Application	It is suitable for applications for which positioning data is predetermined such as a movement amount and target speed.	It is suitable for applications for which positioning data varies depending on the operation according to the operation state.

The extended area is used when the setting values of the positioning table are not determined until just before executing the positioning operation. Therefore, the positioning table can be rewritten as needed, and the recalculation is not necessary. However, it is limited for up to 100 tables and cannot be set by Control Motion Integrator. Therefore, the positioning tables need to be written to the prescribed addresses of unit memories by ladder programs. The start time is longer than that for the standard area, and when performing the P-point or C-point control in the extended area, note that the start time varies depending on the number of tables to be executed consecutively.

The unit memories used for the extended tables are as follows.

**Buffer control area for positioning data**

Buffer no.	Unit memory no. (Hex)	Name	Default	Description						
Buffer 1	UM 06246	Extended positioning table usage setting	H0	Set whether to use the extended positioning table or not. <table border="1"> <thead> <tr> <th>bit</th> <th>Name</th> <th>Description</th> </tr> </thead> <tbody> <tr> <td>15-0</td> <td>Extended positioning table usage setting</td> <td>0: Not make the table setting 1: Make the table setting Any other settings will be errors.</td> </tr> </tbody> </table> * When using the extended positioning table; table nos. 401 to 500 is used as extended table nos. 10,001 to 10,100.	bit	Name	Description	15-0	Extended positioning table usage setting	0: Not make the table setting 1: Make the table setting Any other settings will be errors.
bit	Name				Description					
15-0	Extended positioning table usage setting				0: Not make the table setting 1: Make the table setting Any other settings will be errors.					
Buffer 2	UM 0A0CE									
:	:									
Buffer 12	UM 3121E									
:	:									
Buffer 24	UM 6007E	Extended positioning table usage setting corresponding axis no.	U0	Set transfer axis numbers of positioning data. <table border="1"> <thead> <tr> <th>Range</th> <th>Corresponding axis no.</th> </tr> </thead> <tbody> <tr> <td>1 to 64</td> <td>Corresponds to the existing axes 1 to 64.</td> </tr> <tr> <td>65 to 96</td> <td>Corresponds to the virtual axes 1 to 32.</td> </tr> </tbody> </table> Any other settings will be errors.	Range	Corresponding axis no.	1 to 64	Corresponds to the existing axes 1 to 64.	65 to 96	Corresponds to the virtual axes 1 to 32.
Range	Corresponding axis no.									
1 to 64	Corresponds to the existing axes 1 to 64.									
65 to 96	Corresponds to the virtual axes 1 to 32.									
Buffer 1	UM 06247									
Buffer 2	UM 0A0CF									
:	:									
Buffer 12	UM 3121F									
:	:									
Buffer 24	UM 6007F									

(Note): for details of the unit memory numbers of each buffer, refer to "16.7.4 Configuration of Positioning Data Setting Area".

**Positioning data setting area**

Offset address	Name	Setting range and description												
000H	Control code	<p>Set the position setting mode and acceleration/deceleration pattern for the positioning operation.</p> <table border="1"> <thead> <tr> <th>bit</th> <th>Name</th> <th>Description</th> </tr> </thead> <tbody> <tr> <td>0</td> <td>Control method</td> <td>0: Increment mode 1: Absolute mode</td> </tr> <tr> <td>1</td> <td>Acceleration/deceleration method</td> <td>0: Linear acceleration/deceleration 1: S-shaped acceleration/deceleration</td> </tr> <tr> <td>15-2</td> <td>—</td> <td>—</td> </tr> </tbody> </table>	bit	Name	Description	0	Control method	0: Increment mode 1: Absolute mode	1	Acceleration/deceleration method	0: Linear acceleration/deceleration 1: S-shaped acceleration/deceleration	15-2	—	—
bit	Name	Description												
0	Control method	0: Increment mode 1: Absolute mode												
1	Acceleration/deceleration method	0: Linear acceleration/deceleration 1: S-shaped acceleration/deceleration												
15-2	—	—												
001H	Operation Patterns	<p>Set the single and interpolation operation pattern for the positioning operation. The relation of the interpolation depends on the settings in the axis group setting area in the common area of the unit memory. In the interpolation operation, the setting for the axis with the smallest number in an axis group is effective.</p> <table border="1"> <thead> <tr> <th>bit</th> <th>Name</th> <th>Description</th> </tr> </thead> <tbody> <tr> <td>7-0</td> <td>Control pattern</td> <td>H00: E-point control (End point control) H01: P-point control (Pass point control) H02: C-point control (Continuance point control) H03: J-point control (Speed point control) Any other settings will be errors.</td> </tr> <tr> <td>15-8</td> <td>Interpolation setting</td> <td>H00: Linear interpolation (Composite speed) H01: Linear interpolation (Major axis speed) H10: Circular interpolation (Center point/CW direction) H11: Circular interpolation (Center point/CCW direction) H20: Circular interpolation (Pass point): H50: Spiral interpolation (Center point/CW direction/1st axis feed) H51: Spiral interpolation (Center point/CCW direction/1st axis feed) H52: Spiral interpolation (Center point/CW direction/2nd axis feed) H53: Spiral interpolation (Center point/CCW direction/2nd axis feed) H54: Spiral interpolation (Center point/CW direction/3rd axis feed) H55: Spiral interpolation (Center point/CCW direction/3rd axis feed) H60: Spiral interpolation (Pass point/1st axis feed) H61: Spiral interpolation (Pass point/2nd axis feed) H62: Spiral interpolation (Pass point/3rd axis feed) Any other settings will be errors.</td> </tr> </tbody> </table>	bit	Name	Description	7-0	Control pattern	H00: E-point control (End point control) H01: P-point control (Pass point control) H02: C-point control (Continuance point control) H03: J-point control (Speed point control) Any other settings will be errors.	15-8	Interpolation setting	H00: Linear interpolation (Composite speed) H01: Linear interpolation (Major axis speed) H10: Circular interpolation (Center point/CW direction) H11: Circular interpolation (Center point/CCW direction) H20: Circular interpolation (Pass point): H50: Spiral interpolation (Center point/CW direction/1st axis feed) H51: Spiral interpolation (Center point/CCW direction/1st axis feed) H52: Spiral interpolation (Center point/CW direction/2nd axis feed) H53: Spiral interpolation (Center point/CCW direction/2nd axis feed) H54: Spiral interpolation (Center point/CW direction/3rd axis feed) H55: Spiral interpolation (Center point/CCW direction/3rd axis feed) H60: Spiral interpolation (Pass point/1st axis feed) H61: Spiral interpolation (Pass point/2nd axis feed) H62: Spiral interpolation (Pass point/3rd axis feed) Any other settings will be errors.			
bit	Name	Description												
7-0	Control pattern	H00: E-point control (End point control) H01: P-point control (Pass point control) H02: C-point control (Continuance point control) H03: J-point control (Speed point control) Any other settings will be errors.												
15-8	Interpolation setting	H00: Linear interpolation (Composite speed) H01: Linear interpolation (Major axis speed) H10: Circular interpolation (Center point/CW direction) H11: Circular interpolation (Center point/CCW direction) H20: Circular interpolation (Pass point): H50: Spiral interpolation (Center point/CW direction/1st axis feed) H51: Spiral interpolation (Center point/CCW direction/1st axis feed) H52: Spiral interpolation (Center point/CW direction/2nd axis feed) H53: Spiral interpolation (Center point/CCW direction/2nd axis feed) H54: Spiral interpolation (Center point/CW direction/3rd axis feed) H55: Spiral interpolation (Center point/CCW direction/3rd axis feed) H60: Spiral interpolation (Pass point/1st axis feed) H61: Spiral interpolation (Pass point/2nd axis feed) H62: Spiral interpolation (Pass point/3rd axis feed) Any other settings will be errors.												
002H -003H	Reserved for system	-												
004H	Positioning acceleration time	<p>Set the acceleration and deceleration time for the positioning operation. The acceleration time and deceleration time can be set individually. In the interpolation operation, the setting for the axis with the smallest number in an axis group is effective.</p>												
005H	Positioning deceleration time	<p>Set the acceleration/deceleration time of the control.</p> <table border="1"> <thead> <tr> <th>bit</th> <th>Name</th> <th>Description</th> </tr> </thead> <tbody> <tr> <td>15-0</td> <td>Acceleration time Deceleration time</td> <td>Range: 0 to 10,000 (ms) Any other settings will be errors.</td> </tr> </tbody> </table>	bit	Name	Description	15-0	Acceleration time Deceleration time	Range: 0 to 10,000 (ms) Any other settings will be errors.						
bit	Name	Description												
15-0	Acceleration time Deceleration time	Range: 0 to 10,000 (ms) Any other settings will be errors.												

Offset address	Name	Description								
006H -007H	Positioning target speed (Interpolation speed)	<p>For a single axis operation, it is the target speed of the corresponding axis. For an interpolation operation, it is the target speed of the interpolation. In the interpolation operation, the setting for the axis with the smallest number in an axis group is effective.</p> <table border="1"> <thead> <tr> <th>bit</th> <th>Name</th> <th>Default</th> <th>Description</th> </tr> </thead> <tbody> <tr> <td>31-0</td> <td>Positioning target speed (Interpolation speed)</td> <td>1,000</td> <td>                     Range: 1 to 2,147,483,647                      Any other settings will be errors.                      The ranges vary depending on the unit settings as below.                      Pulse: 1 to 2,147,483,647 pps  <math>\mu\text{m}</math>: 1 to 2,147,483,647 <math>\mu\text{m/s}</math>                      inch: 0.001 to 2,147,483.647 inch/s                      degree: 0.001 to 2,147,483.647 rev/s                 </td> </tr> </tbody> </table>	bit	Name	Default	Description	31-0	Positioning target speed (Interpolation speed)	1,000	Range: 1 to 2,147,483,647 Any other settings will be errors. The ranges vary depending on the unit settings as below. Pulse: 1 to 2,147,483,647 pps $\mu\text{m}$ : 1 to 2,147,483,647 $\mu\text{m/s}$ inch: 0.001 to 2,147,483.647 inch/s degree: 0.001 to 2,147,483.647 rev/s
bit	Name	Default	Description							
31-0	Positioning target speed (Interpolation speed)	1,000	Range: 1 to 2,147,483,647 Any other settings will be errors. The ranges vary depending on the unit settings as below. Pulse: 1 to 2,147,483,647 pps $\mu\text{m}$ : 1 to 2,147,483,647 $\mu\text{m/s}$ inch: 0.001 to 2,147,483.647 inch/s degree: 0.001 to 2,147,483.647 rev/s							
008H -009H	Positioning movement amount	<p>Set the movement amount for the positioning operation. The interpretation changes between the increment movement amount and absolute coordinate depending on the control code setting.</p> <table border="1"> <thead> <tr> <th>bit</th> <th>Description</th> </tr> </thead> <tbody> <tr> <td>31-0</td> <td>                     Setting range: -2,147,483,648 to 2,147,483,647                      The ranges vary depending on the unit settings as below.                      pulse: -2,147,483,648 to 2,147,483,647 pulse  <math>\mu\text{m}</math> (0.1<math>\mu\text{m}</math>): -214,748,364.8 to 214,748,364.7 <math>\mu\text{m}</math>  <math>\mu\text{m}</math> (1<math>\mu\text{m}</math>): -2,147,483,648 to 2,147,483,647 <math>\mu\text{m}</math>                      inch (0.00001 inch): -21,474.83648 to 21,474.83647 inches                      inch (0.0001 inch): -214,748.3648 to 214,748.3647 inches                      degree (0.1 degree): -214,748,364.8 to 214,748,364.7 degrees                      degree (1 degree): -2,147,483,648 to 2,147,483,647 degrees                      Any other settings will be errors. (Max. 31 bits)                 </td> </tr> </tbody> </table>	bit	Description	31-0	Setting range: -2,147,483,648 to 2,147,483,647 The ranges vary depending on the unit settings as below. pulse: -2,147,483,648 to 2,147,483,647 pulse $\mu\text{m}$ (0.1 $\mu\text{m}$ ): -214,748,364.8 to 214,748,364.7 $\mu\text{m}$ $\mu\text{m}$ (1 $\mu\text{m}$ ): -2,147,483,648 to 2,147,483,647 $\mu\text{m}$ inch (0.00001 inch): -21,474.83648 to 21,474.83647 inches inch (0.0001 inch): -214,748.3648 to 214,748.3647 inches degree (0.1 degree): -214,748,364.8 to 214,748,364.7 degrees degree (1 degree): -2,147,483,648 to 2,147,483,647 degrees Any other settings will be errors. (Max. 31 bits)				
bit	Description									
31-0	Setting range: -2,147,483,648 to 2,147,483,647 The ranges vary depending on the unit settings as below. pulse: -2,147,483,648 to 2,147,483,647 pulse $\mu\text{m}$ (0.1 $\mu\text{m}$ ): -214,748,364.8 to 214,748,364.7 $\mu\text{m}$ $\mu\text{m}$ (1 $\mu\text{m}$ ): -2,147,483,648 to 2,147,483,647 $\mu\text{m}$ inch (0.00001 inch): -21,474.83648 to 21,474.83647 inches inch (0.0001 inch): -214,748.3648 to 214,748.3647 inches degree (0.1 degree): -214,748,364.8 to 214,748,364.7 degrees degree (1 degree): -2,147,483,648 to 2,147,483,647 degrees Any other settings will be errors. (Max. 31 bits)									
00AH -00BH	Auxiliary point	<p>Set the auxiliary point (coordinate of center or pass point) in the case of circular interpolation or spiral interpolation control.</p> <table border="1"> <thead> <tr> <th>bit</th> <th>Description</th> </tr> </thead> <tbody> <tr> <td>31-0</td> <td>                     Setting range: -2,147,483,648 to 2,147,483,647                      The ranges vary depending on the unit settings as below.                      pulse: -2,147,483,648 to 2,147,483,647 pulse  <math>\mu\text{m}</math> (0.1<math>\mu\text{m}</math>): -214,748,364.8 to 214,748,364.7 <math>\mu\text{m}</math>  <math>\mu\text{m}</math> (1<math>\mu\text{m}</math>): -2,147,483,648 to 2,147,483,647 <math>\mu\text{m}</math>                      inch (0.00001 inch): -21,474.83648 to 21,474.83647 inches                      inch (0.0001 inch): -214,748.3648 to 214,748.3647 inches                      degree (0.1 degree): -214,748,364.8 to 214,748,364.7 degrees                      degree (1 degree): -2,147,483,648 to 2,147,483,647 degrees                      Any other settings will be errors. (Max. 31 bits)                 </td> </tr> </tbody> </table>	bit	Description	31-0	Setting range: -2,147,483,648 to 2,147,483,647 The ranges vary depending on the unit settings as below. pulse: -2,147,483,648 to 2,147,483,647 pulse $\mu\text{m}$ (0.1 $\mu\text{m}$ ): -214,748,364.8 to 214,748,364.7 $\mu\text{m}$ $\mu\text{m}$ (1 $\mu\text{m}$ ): -2,147,483,648 to 2,147,483,647 $\mu\text{m}$ inch (0.00001 inch): -21,474.83648 to 21,474.83647 inches inch (0.0001 inch): -214,748.3648 to 214,748.3647 inches degree (0.1 degree): -214,748,364.8 to 214,748,364.7 degrees degree (1 degree): -2,147,483,648 to 2,147,483,647 degrees Any other settings will be errors. (Max. 31 bits)				
bit	Description									
31-0	Setting range: -2,147,483,648 to 2,147,483,647 The ranges vary depending on the unit settings as below. pulse: -2,147,483,648 to 2,147,483,647 pulse $\mu\text{m}$ (0.1 $\mu\text{m}$ ): -214,748,364.8 to 214,748,364.7 $\mu\text{m}$ $\mu\text{m}$ (1 $\mu\text{m}$ ): -2,147,483,648 to 2,147,483,647 $\mu\text{m}$ inch (0.00001 inch): -21,474.83648 to 21,474.83647 inches inch (0.0001 inch): -214,748.3648 to 214,748.3647 inches degree (0.1 degree): -214,748,364.8 to 214,748,364.7 degrees degree (1 degree): -2,147,483,648 to 2,147,483,647 degrees Any other settings will be errors. (Max. 31 bits)									

## Automatic Operation (Position Control)

Offset address	Name	Description								
00CH	Dwell time	After the completion of the positioning operation of this table; when the mode is C: Continuance point, the motor stops for the dwell time and the next operation is started. When the mode is P: Pass point, it is ignored. When the mode is E: End point, the positioning done contact turns on after waiting for the dwell time.								
		<table border="1"> <thead> <tr> <th>bit</th> <th>Name</th> <th>Default</th> <th>Description</th> </tr> </thead> <tbody> <tr> <td>15-0</td> <td>Dwell time</td> <td>0</td> <td>Range: 0 to 32,767 (ms) Any other settings will be errors.</td> </tr> </tbody> </table>	bit	Name	Default	Description	15-0	Dwell time	0	Range: 0 to 32,767 (ms) Any other settings will be errors.
		bit	Name	Default	Description					
15-0	Dwell time	0	Range: 0 to 32,767 (ms) Any other settings will be errors.							
00DH	Auxiliary output code	Sets the data to be output to the auxiliary output code in each axis information & monitor area by the setting of the auxiliary output mode in the parameter setting area.								
		<table border="1"> <thead> <tr> <th>bit</th> <th>Name</th> <th>Default</th> <th>Description</th> </tr> </thead> <tbody> <tr> <td>15-0</td> <td>Auxiliary output code</td> <td>0</td> <td>Set an arbitrary value.</td> </tr> </tbody> </table>	bit	Name	Default	Description	15-0	Auxiliary output code	0	Set an arbitrary value.
		bit	Name	Default	Description					
15-0	Auxiliary output code	0	Set an arbitrary value.							
00EH -01FH	Reserved for system	—								

8.10.2 Sample Program (Extended Table)

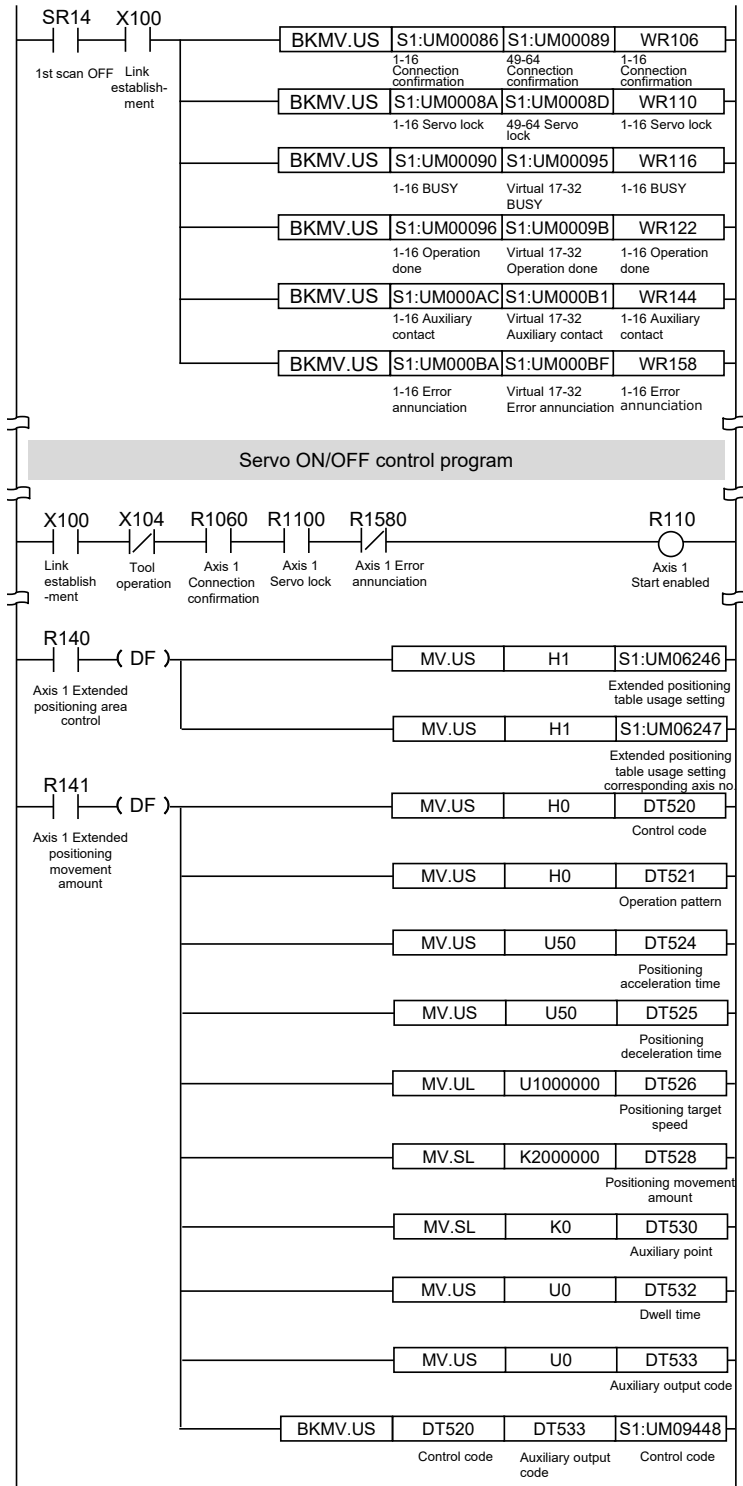

# Automatic Operation (Position Control)

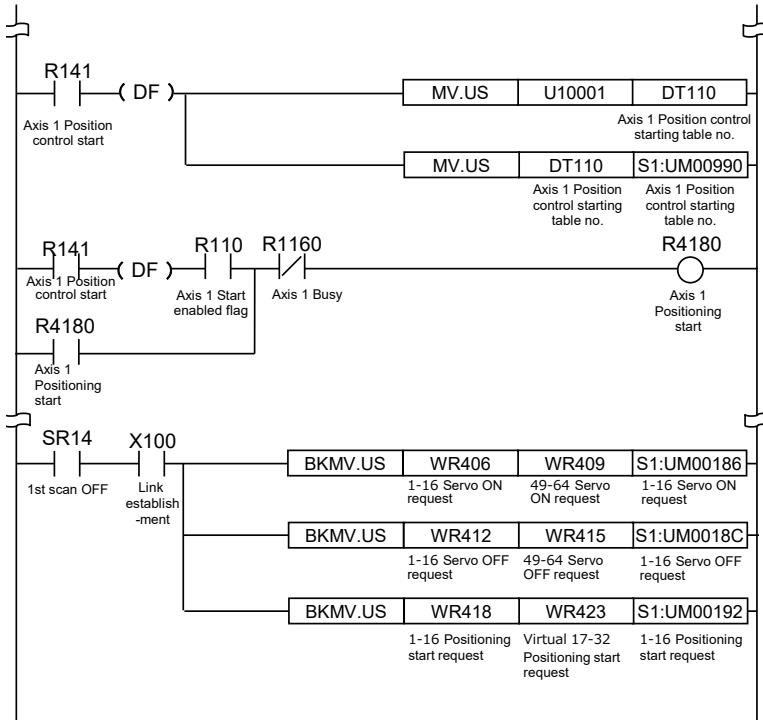



# 9

## **Automatic Operation (Synchronous Control)**

## 9.1 Synchronous Control

---

### 9.1.1 Overview of Synchronous Control

---

#### ■ What is synchronous control?

In the synchronous control, by operating a reference axis (master axis), the axes (slave axes) interlocking (synchronizing) with the master axis are activated. The advantages of using the synchronous control are as follows.

#### 1. Ease of setting

A number of related axes can be operated with ease by designing the operation of the axes based on the master axis.

#### 2. Ensuring operational safety

If an axis comes to a stop for some reason while the positioning unit is in synchronous control, all the relevant axes under synchronous control will come to a stop. Therefore, you can easily increase the safety of the positioning unit.

#### ■ Functions of control output

The synchronous control provides the following functions. These functions are executed in order, and the slave axes operate according to the operation result of each function.

Function	Overview
Electronic gear	The number of pulses multiplied by the preset electronic gear ratio is output according to the operation of the master axis.
Phase clutch OFF	A function to turn off an electronic clutch at an arbitrarily specified phase.
Electronic clutch	The operation of the slave axes can be separated from the operation of the master axis by disengaging the clutch.
Advance angle correction	A function to electrically correct the delay in the response of a machine system connected to an electronic cam output or the delay in a PLC arithmetic processing time.
Electronic cam	A function to output pulses according to the preset cam pattern. Calculates the operation phase of the master axis and outputs cam pulses according to the phase. The cam pattern is set by CMI.

■ Execution order of synchronous control and setting procedures

The following section provides information on the outline of functions achieved by synchronous control and setting procedures for the functions.

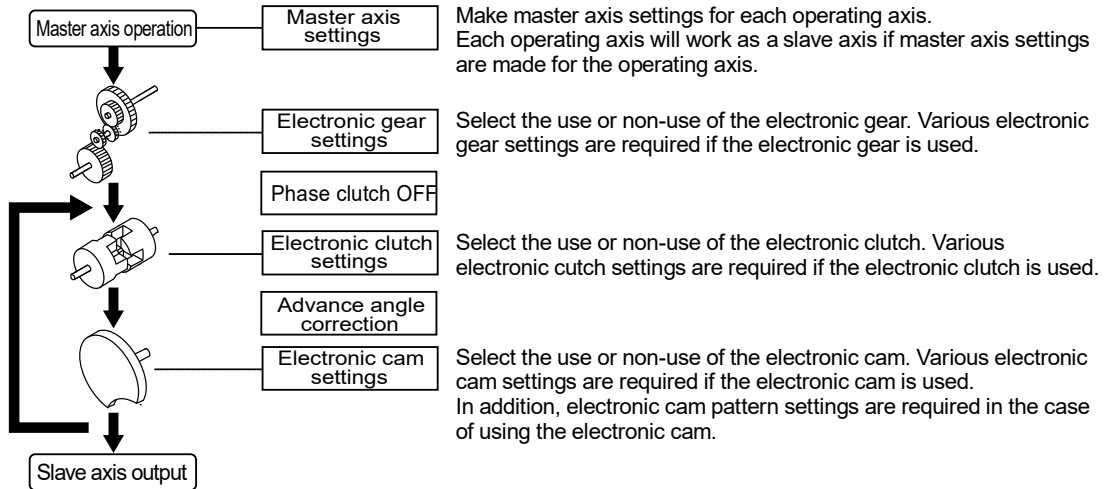

## 9.2 Settings for Master and Slave Axes

### 9.2.1 Selection of Master Axis and Settings

The master axis serves as a reference for synchronization control. Start and stop requests for various operations are made to the master axis under synchronous control. It is possible to select one of the following master axes.

#### ■ Type of master axis

Master axis type	Description
Real axis	Use one of them if the master axis needs to be an object of control as well. If a real axis is used as the master axis, the rest of the real axes can be used as slave axes.
Virtual axis	It is a virtual axis controlled within FP7 MC Unit. The virtual axis can be used only as the master axis. Real axes can be used effectively by using the virtual axis.

#### ■ Type of master axis and restrictions

Operation mode	Usable axis		Remarks	
	Real axis	Virtual axis		
Home return	○	△	Virtual axes are available only for "Data set" method.	
JOG operation	○	○		
Positioning	Single axis	○		
	Interpolation axis	○	○	Available in any of the following combinations. Real axis + Real axis Virtual axis + Real axis Virtual axis + Virtual axis
Stop function	System stop Emergency stop Deceleration stop	○	○	
	Limit stop	○	△	For virtual axes, only the stop by software limit is available.
	Error stop	○	○	



#### ◆ KEY POINTS

- While the unit is in synchronous control, slave axes set to use the master axis operate only in synchronization with the master axis, i.e., the slave axes cannot operate independently.
- For using the virtual axis, check the box for the virtual axis in the dialog box to select used axes in "CMI".
- The home return of the virtual axis is possible only by data setting.

## 9.2.2 Selection of Slave Axes and Settings

### ■ Selection of slave axes

- Axes that can be used as slave axes are real axes. Virtual axes can be used only as the master axis.
- Axes set as slave axes operate in synchronization with the master axis as long as synchronous control is enabled. No slave axes can perform positioning and other control independently from the master axis while synchronous control is enabled.

### ■ Settings for slave axes

Slave axes operate in synchronization with the master axis. Set the following items, however, for each individual slave axis.

- Unit setting
- Numbers of pulses per revolution
- Movement per revolution

## 9.2.3 Unit Type and Number of Axes

FP7 MC Unit model number	Number of usable axes	
	Real axis	Virtual axis
AFP7MC16EC	Max. 16 axes	Max. 8 axes
AFP7MC32EC	Max. 32 axes	Max. 16 axes
AFP7MC64EC	Max. 64 axes	Max. 32 axes

## 9.2.4 Setting by CMI

Master and slave axes are allocated using CMI. The following procedure is explained on the condition that CMI has already started. In the following example, AFP7MC16EC (16-real axes, 8-virtual axes) type is used, and the axis 1 is allocated to the master and the axes 2 and 3 are allocated to slave axes.



### ◆ PROCEDURE

1. Select "Parameter" > "Synchronous parameter settings" > "Axis 2" from the menu bar.

The "Synchronous parameter Axis 2" window opens.

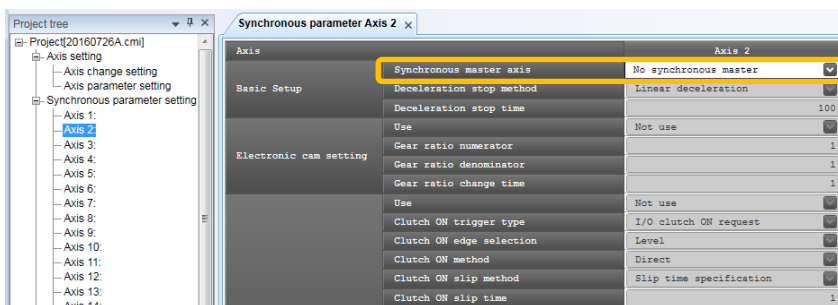

2. Select "Axis 1" from the drop-down list of "Basic setup" > "Synchronous master axis".

The hierarchy of "Axis 2" in the project tree is changed. Also, the items in the electronic gear, electronic clutch and electronic cam settings of "Synchronous parameter Axis 2" become available.

3. Select "Parameter" > "Synchronous parameter settings" > "Axis 3" from the menu bar.

The "Synchronous parameter Axis 3" window opens.

4. Select "Axis 1" from the drop-down list of "Basic setup" > "Synchronous master axis".

The hierarchy of "Axis 3" in the project tree is changed. Also, the items in the electronic gear, electronic clutch and electronic cam settings of "Synchronous parameter Axis 3" become available.

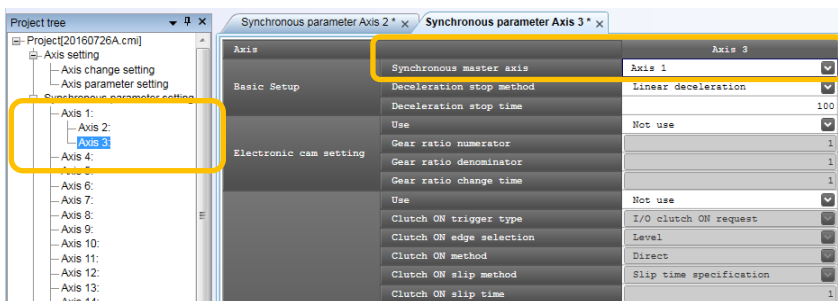

## 9.3 Start and Cancel of Synchronous Control

### 9.3.1 Start and Cancel of Synchronous Control

■ **Start and cancel operations**

- The synchronous control can be temporarily canceled by turning on "Synchronous cancel request" in the output control area of unit memories.
- It is possible to operate any slave axes individually while the synchronous state is canceled.
- The synchronous control can be started again with the sync cancel request signal turned off.
- The synchronous control can be canceled while a master axis is activated. (This function is available since FP7 MC Unit Ver.1.2.)

■ **Synchronous cancel request/annunciation signals**

Signal name	Real axis				Virtual axis	
	Axes 1-16	Axes 17-32	Axes 33-48	Axes 49-64	Axes 1-16	Axes 17-32
Synchronous cancel request Corresponding bit ON: Synchronization is canceled. Corresponding bit OFF: Synchronization is executed.	UM001DA	UM001DB	UM001DC	UM001DD	-	-
Synchronous cancel active annunciation Corresponding bit ON: Synchronization is being canceled. Corresponding bit OFF: Synchronization is being processed.	UM000CC	UM000CD	UM000CE	UM000CF	-	-

(Note 1): Flags or request signals for 16 axes are allocated to each unit memory (1 word).

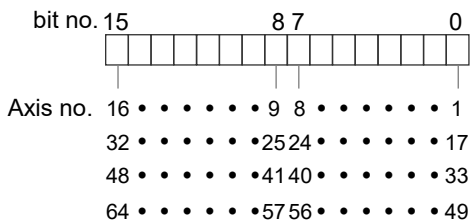

■ Operations while synchronous control is performed/canceled

Operation mode		Operation during synchronization		Operation while synchronization is being canceled
		When requesting operation for master axis	When requesting operation for slave axis	When requesting operation for master/slave axis
Home return		<p>Home return operation is performed on the master axis.</p> <p>Home return operation is not performed on slave axes.</p> <p>Synchronous operation is performed in synchronization with output from the master axis.</p> <p>For performing home return operation on slave axes, cancel the synchronous operation.</p>	<p>The slave axes do not operate in response to operation requests.</p>	<p>Regardless of master or slave axes, home return operation are performed only on the axes are so requested.</p>
JOG operation		<p>The slave axes operate in synchronization with the operation request of the master axis.</p>		<p>Regardless of master or slave axes, JOG operation are performed only on the axes are so requested.</p>
Positioning	Single axis			<p>Interpolation is executed upon request if the master axis is the start axis of interpolation.</p> <p>The slave axes operate in synchronization with the master axis.</p>
	Interpolation axis	<p>Interpolation is executed upon request if the requested axis is the start axis of interpolation.</p>		
Stop function	System stop	All the axes come to a stop regardless of the synchronization settings.		
	Emergency stop	The master axis comes to a stop upon request.	Only axes requested come to a stop.	Only axes requested come to a stop.
	Deceleration stop	The slave axes come to a stop in synchronization with the master axis.	The master axis and other slave set on the same master axis continue operating.	(All the target axes in interpolation operation come to a stop.)
	Limit stop	The master axis and all the slave axes come to a stop.		Only axes resulting in a limit error come to a stop.
	Error stop			Only axes resulting in an error come to a stop.



### 9.3.2 Precautions When Canceling or Starting Synchronous Control

---

#### ■ Precautions when canceling synchronous control

- The synchronous control can be canceled during the master operation; however, slave axes will stop immediately.
- It is recommended to cancel the synchronous control after stopping slave axes using the clutch function.
- When the synchronous control is canceled, flags related to the synchronous control (slave axis gear ratio change annunciation, slave axis clutch operation annunciation) will turn off.

#### ■ Conditions for starting synchronous control

Only when the following conditions are met, the synchronous control can be started.

- Slave axes stop.
- No stop request for slave axes is generated.
- No error occurs in slave axes.

When these conditions are not met, the unit does not become the synchronous state and the synchronous control cancel active annunciation relay does not turn off. If the synchronous cancel request kept off while the conditions are not met, the synchronous control will start once the condition to start the synchronous control is met.

■ Phase when starting synchronous control

It is calculated from the "current value after unit conversion" of master axis and the "cam control synchronous master axis cycle" of synchronous parameter. The remainder obtained by dividing "current value after unit conversion" by "cam control synchronous master axis cycle" is used as a phase.

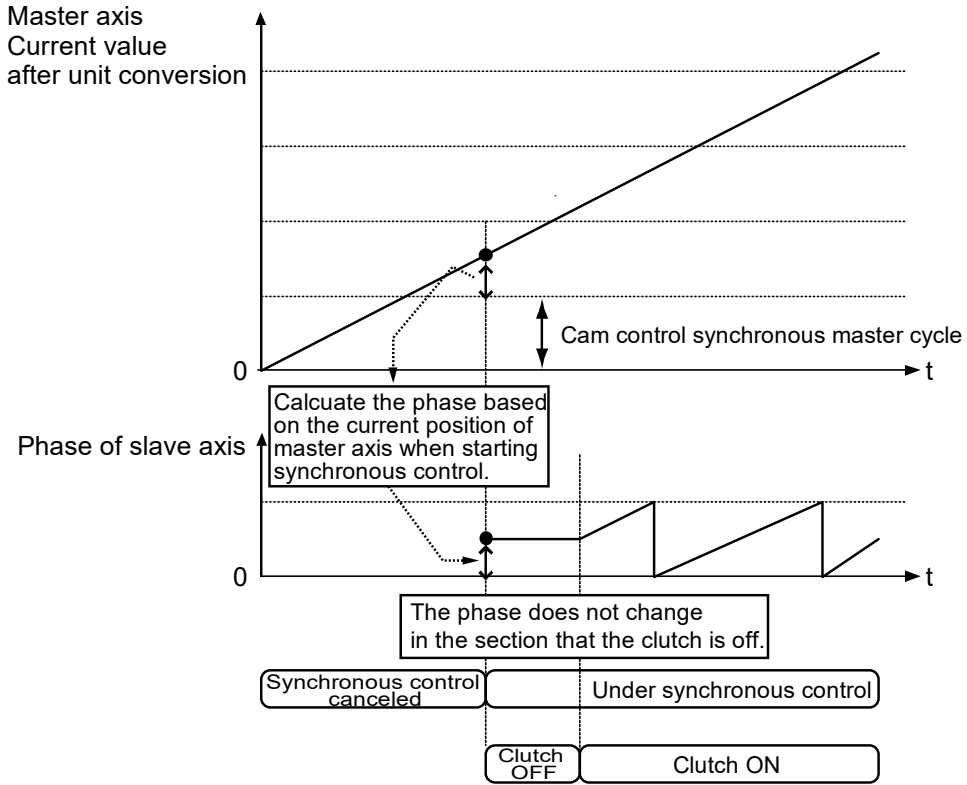

■ Procedures of canceling and starting synchronous control

The following shows the procedures when selecting "Level" for the clutch ON edge selection, "Slip" for the clutch ON method and clutch OFF method.

Section	Procedure	Operation by user programs and unit operation
Synchronous canceled	①	Turn off the slave axis clutch on request by a user program.
	②	FP7 MC Unit turns off the slave axis clutch operation annunciation.
	③	Turn on the synchronous cancel request by a user program.
	④	FP7 MC Unit cancels the synchronous control when the synchronous cancel active annunciation turns on.
Synchronous started	⑤	Turn off the synchronous state cancel request by a user program.
	⑥	FP7 MC Unit turns off the synchronous cancel active annunciation.
	⑦	Turn on the slave axis clutch on request by a user program.
	⑧	FP7 MC Unit starts the synchronous operation of slave axes when the slave axis clutch operation annunciation turns on.

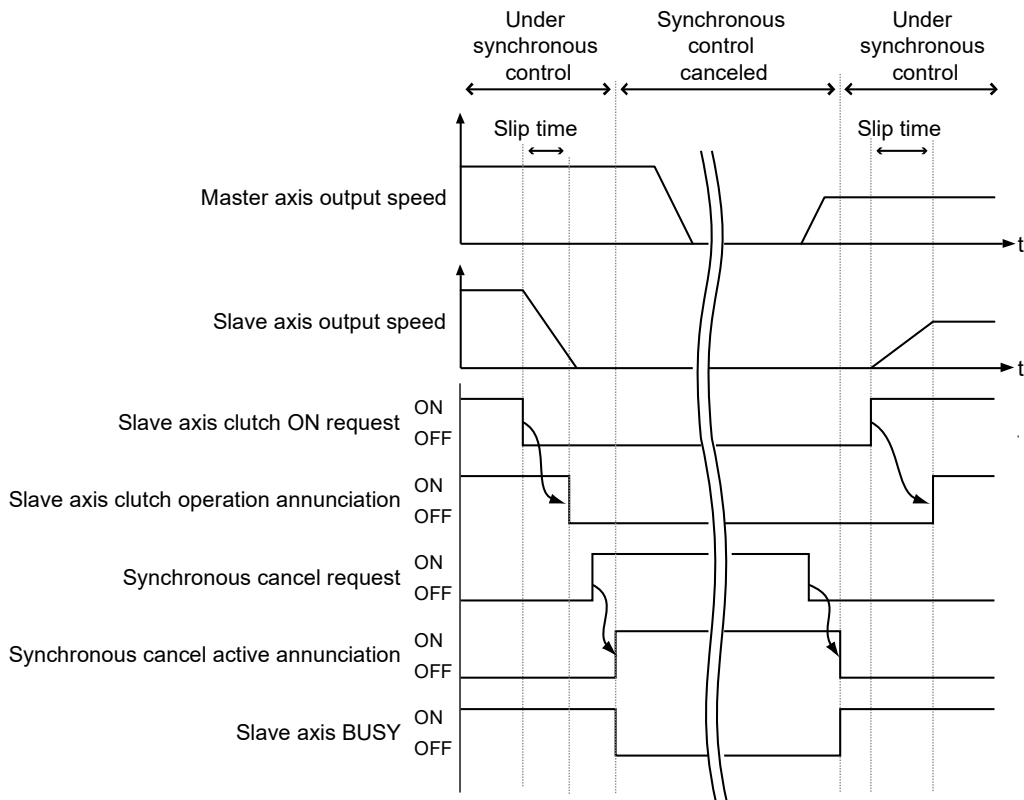

■ I/O allocation

Signal name	Real axis				Virtual axis	
	Axes 1-16	Axes 17-32	Axes 33-48	Axes 49-64	Axes 1-16	Axes 17-32
Synchronous cancel request	UM001DA	UM001DB	UM001DC	UM001DD	-	-
Synchronous cancel active annunciation	UM000CC	UM000CD	UM000CE	UM000CF	-	-
Slave axis BUSY	UM00090	UM00091	UM00092	UM00093	UM00094	UM00095
Slave axis operation done	UM00096	UM00097	UM00098	UM00099	UM0009A	UM0009B

■ Operation when selecting "Level" for the clutch ON edge selection

- If the "slave axis clutch ON request" is on when the synchronous control start processing is executed, the clutch is connected by the direct method regardless of the setting of "clutch ON method".
- However, if the "slave axis clutch ON request" is off when the synchronous control start processing is executed, the clutch is connected according to the setting of "clutch ON method".

When the slave axis clutch ON request is on when the synchronous control start processing is executed

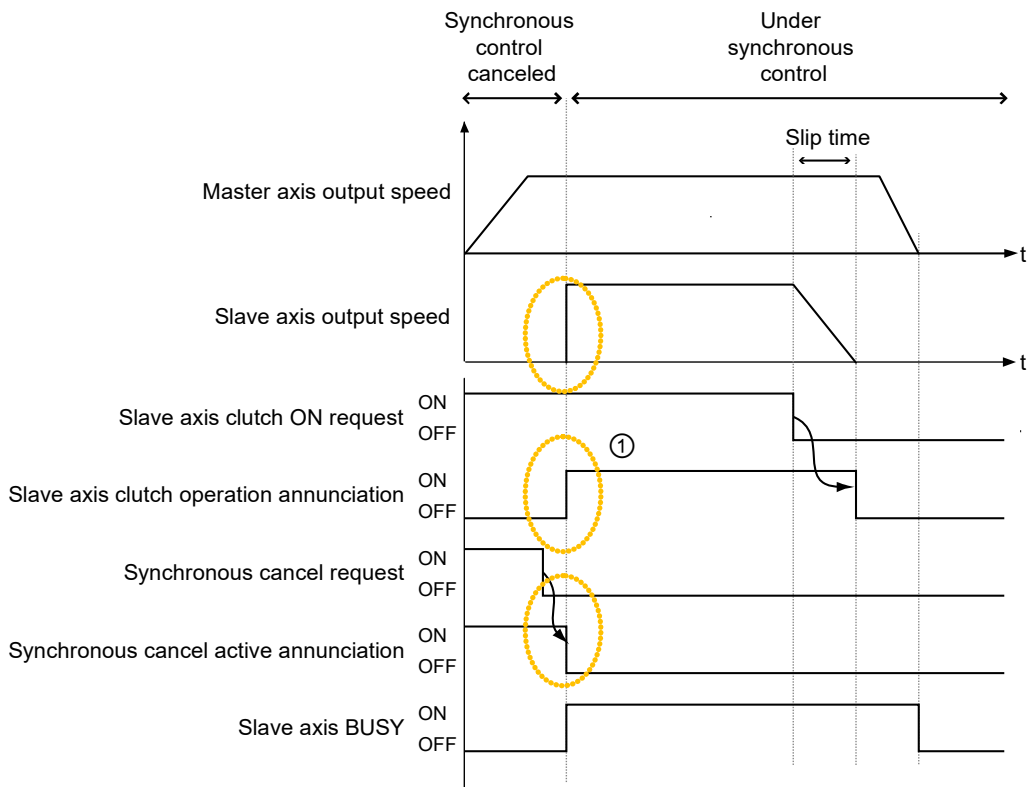

① The slave axes start the operation immediately as the clutch is connected (slave axis clutch operation annunciation: on) when the synchronous control starts (synchronous cancel active annunciation: off).

**When the slave axis clutch ON request is off when the synchronous control start processing is executed**

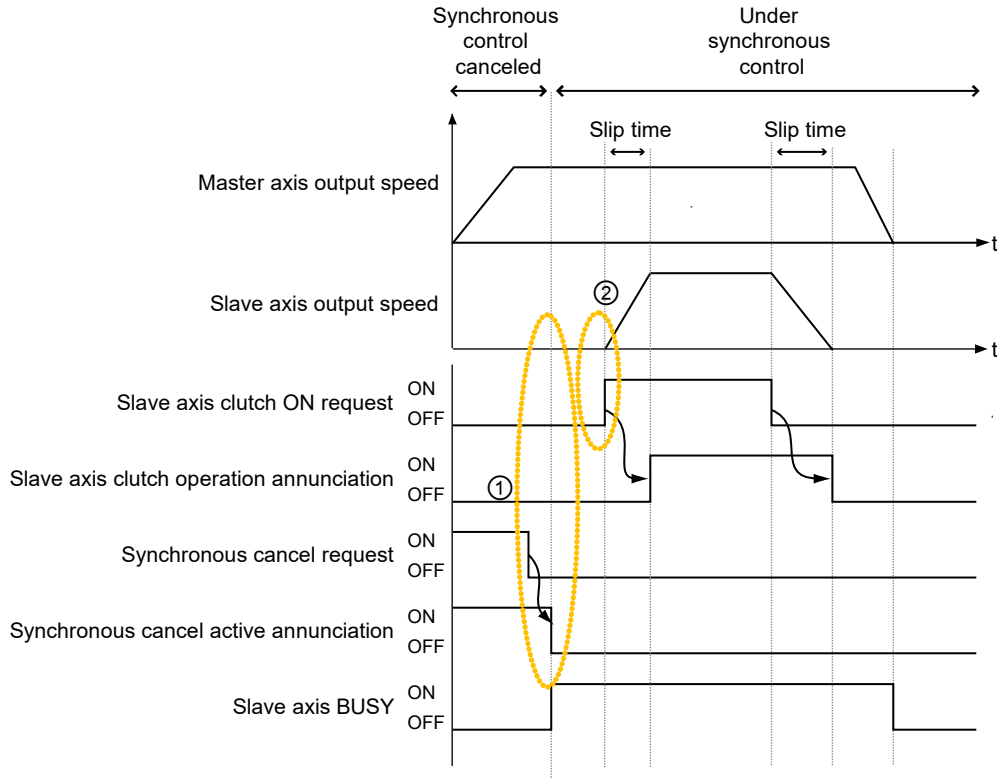

①	The slave axes do not operate immediately as the clutch is not connected (slave axis clutch operation annunciation: off) when the synchronous control starts (synchronous cancel active annunciation: off).
②	Slave axes start the operation by the slave axis clutch ON request.

■ I/O allocation

Signal name	Real axis				Virtual axis	
	Axes 1-16	Axes 17-32	Axes 33-48	Axes 49-64	Axes 1-16	Axes 17-32
Synchronous cancel request	UM001DA	UM001DB	UM001DC	UM001DD	-	-
Synchronous cancel active annunciation	UM000CC	UM000CD	UM000CE	UM000CF	-	-
Slave axis BUSY	UM00090	UM00091	UM00092	UM00093	UM00094	UM00095
Slave axis operation done	UM00096	UM00097	UM00098	UM00099	UM0009A	UM0009B

(Note 1): The I/O numbers in the above table show relative addresses based on the base word number. The I/O numbers actually used vary according to the slot number where the unit is installed and the starting word number.

## 9.4 Electronic Gear Function

### 9.4.1 Overview of Electronic Gear Function

#### ■ Electronic gear function

The electronic gear function operates the positioning unit at the speed of the master axis multiplied by a preset gear ratio.

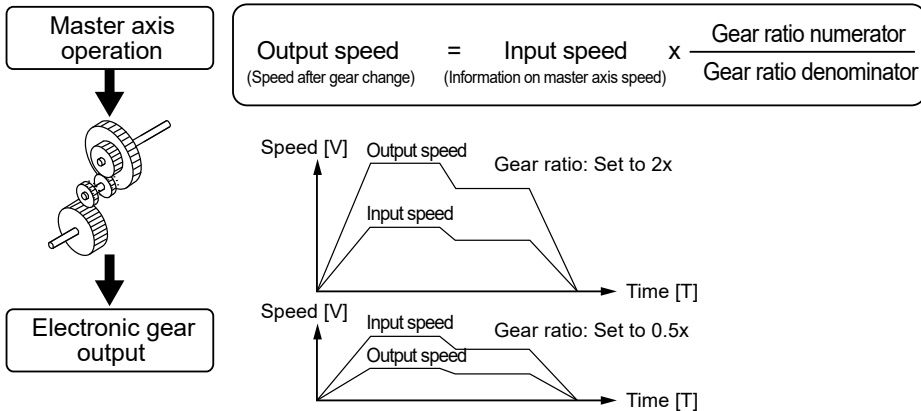

#### ■ Cautions when using the electronic gear function

The use of the electronic gear function makes it possible to set the slave axes to a desired speed relative to the master axis.

Movement amount of slave axes

$$= \text{Movement amount of master axis} \times \left( \frac{\text{gear ratio numerator}}{\text{Gear ratio denominator}} \right)$$

\* On the condition that the gear ratios are constant

Do not use the electronic gear function if the movement amount of the master axis needs to coincide with that of the slave axes.



#### ◆ NOTES

- Keep in mind that the slave axes may come to a sudden stop if an emergency stop or deceleration stop is executed while make a gear ratio change.

## 9.4.2 Types and Contents of Setting Parameters

For using the electronic gear, set the following parameters in the "Synchronous parameter settings" menu.

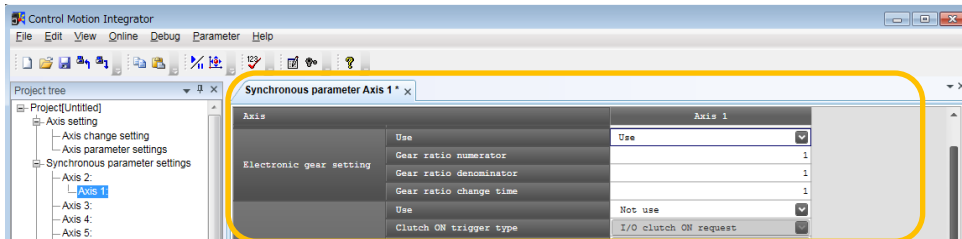

Parameter name	Default	Description
Electronic gear setting - Use	Not use	Select the operation of the electronic gear function. Use / Not use The gear ratio of the electronic gear is set to 1:1 if the electronic gear is not used, and the operation of the master axis is input as it is into the electronic clutch.
Gear ratio numerator	1	Determines the gear ratio of the electronic gear. Electronic gear ratio is determined by the following formula. Output speed of electronic gear = Operating speed of master axis x (Gear ratio numerator/Gear ratio denominator) Setting range: U1 to U2147483647
Gear ratio denominator	1	
Gear ratio change time	1	The time required to change the current gear ratio to a new gear ratio if the new gear ratio is set for the electronic gear in operation. Setting range: U1 to U10000 (ms)



### ◆ KEY POINTS

- The gear ratio of the electronic gear is set to 1:1 when selecting "Not use" for the electronic gear, and the operation of the master axis is input as it is into the electronic clutch.

### 9.4.3 Gear Ratio Changes while in Operation

**■ Precautions for gear ratio changes while the positioning unit is in operation**

- If the gear ratio is changed with a new gear ratio while the electronic gear is in operation, the new gear ratio will be effective with an elapse of a preset gear change time.
- If the gear ratio change time is 1, the gear ratio will be changed at an acceleration/deceleration time of 0.
- Acceleration or deceleration during the gear ratio change results in linear acceleration or deceleration. S-shaped acceleration or deceleration cannot be used.

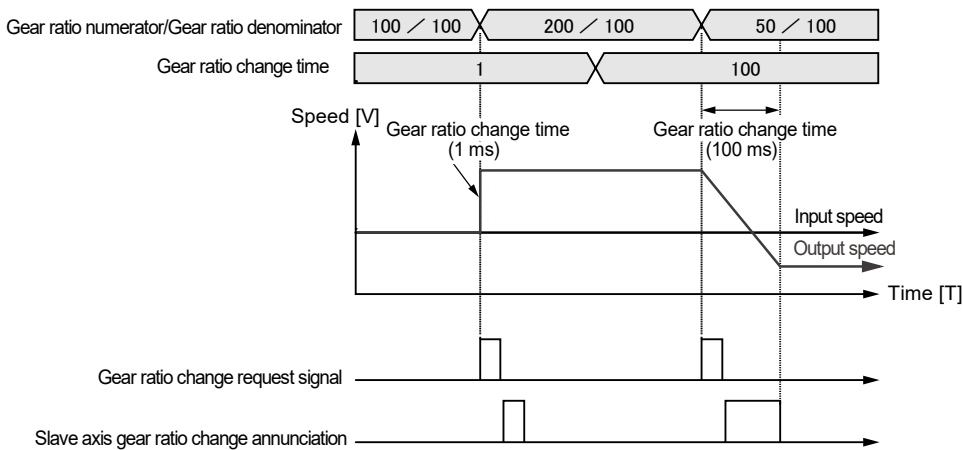

**■ Programming method**

Follow the procedure below and write a user program in the case of changing the gear ratio while the positioning unit is in operation.

**1. Gear ratio change**

- Change the gear ratio numerator and denominator of the electronic gear in the setting area for the electronic gear.
- The gear ratio at the time of starting the unit is set for this area. It is recommended to save the initial gear ratio before change so that the initial gear ratio can be reused with ease.

**2. Gear ratio change request**

- Turn on an I/O signal (electronic gear ratio change request) for the target axis allocated to the unit.
- This signal becomes enabled by the "edge type" operation. Starts the gear ratio change triggered by the gear ratio change request signal turned on.
- Turn off the gear ratio change request signal after changing the gear ratio.



■ Gear ratio change request signal

Signal name	Real axis			
	Axes 1-16	Axes 17-32	Axes 33-48	Axes 49-64
Slave axis gear ratio change request	UM001E0	UM001E1	UM001E2	UM001E3
Slave axis gear ratio change annunciation	UM000D2	UM000D3	UM000D4	UM000D5

(Note 1): Flags or request signals for 16 axes are allocated to each unit memory (1 word). When the value of each bit is 1, it turns on. When the value of each bit is 0, it turns off.

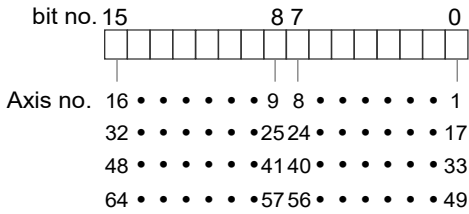

◆ REFERENCE

- For details of gear ratio setting area, refer to "16.8.3 Electronic Gear Setting Area".

## 9.5 Electronic Clutch Function

---

### 9.5.1 What is Electronic Clutch Function?

---

The electronic clutch function is used to engage or disengage the clutch for output from the electronic gear. When the electronic clutch is disengaged, the master axis is separated from the slave axes and the slave axes not in synchronization with the master axis come to a stop. When the electronic clutch is engaged, the master axis and slave axes operate in synchronization.

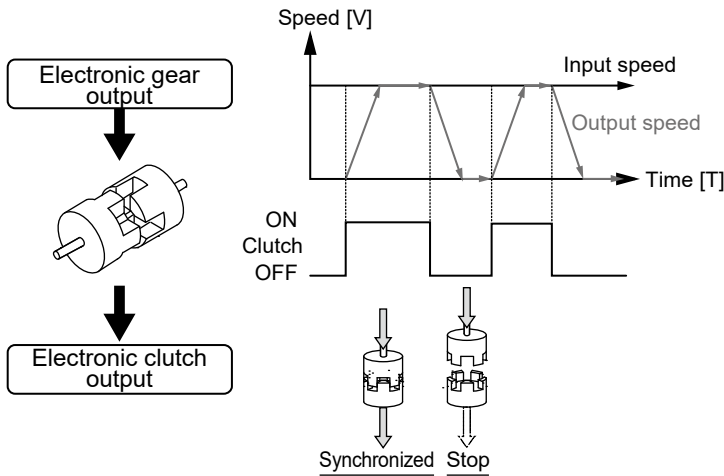

#### NOTES

---

- Keep in mind that the slave axes may come to a sudden stop if the clutch is disengaged while making a gear ratio change.



#### KEY POINTS

---

- The electronic clutch is by default disengaged. Be sure to engage the electronic clutch in response to the operation.

### 9.5.2 Types and Contents of Setting Parameters

For using the electronic clutch, set the following parameters in the "Synchronous parameter settings" menu.

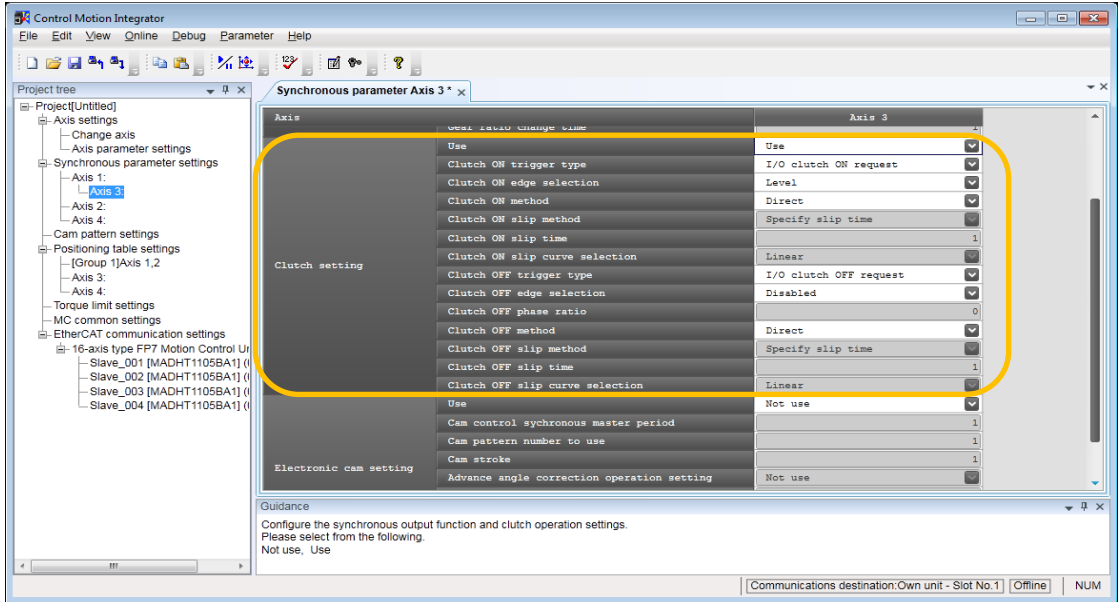

Parameter name		Description
Clutch setting - Use		Select the operation of the electronic clutch function. Use / Not use
Clutch ON	Trigger type	Set an I/O clutch ON request as a trigger to be detected.
	Edge selection	Select "Level", "Leading edge" or "Trailing edge" for the method of detecting trigger signals.
	Method	Select "Direct" or "Slip" for the engagement of the clutch.
	Slip method	Select "Slip time specification".
	Slip time	If "Slip" is selected, set the slip time. Range: 1 to 10000 ms
	Slip curve selection	Select "Linear".
Clutch OFF	Trigger type	Select "I/O clutch OFF request" or "Phase after I/O clutch" as a trigger to be detected.
	Edge selection	Select "Disabled", "Leading edge" or "Trailing edge" for the method of detecting trigger signals.
	Phase ratio	Set the ratio for the phase at which the clutch turns off when selecting "Phase after I/O clutch" for the clutch trigger type. Range: 0 to 99 (%)
	Method	Select "Direct" or "Slip" for the engagement of the clutch.
	Slip method	Select "Slip time specification".
	Slip time	If "Slip" is selected, set the slip time. Range: 1 to 10000 ms
	Slip curve selection	Select "Linear".

(Note 1): "Clutch OFF trigger type" is selectable when "Clutch ON trigger type" is set to "Leading edge" or "Trailing edge".



◆ **KEY POINTS**

---

- The electronic clutch is always engaged when setting the electronic clutch setting to "Not use", and output data from the electronic gear is input as it is into the electronic cam. At that time, the master axis always operates in synchronization with the slave axes.
- The mode (I/O + Phase after clutch) has been added to stop the motors of slave axes at an arbitrary phase after turning off the clutch. This function is available since FP7 MC Unit Ver. 1.20. For details, refer to "9.5.5 Phase Specification Clutch OFF Function".

### 9.5.3 Trigger Types for Electronic Clutch

The connection (ON)/disconnection (OFF) of the electronic clutch is performed by controlling the ON request or OFF request in the output control area of the unit memories using user programs. The following methods are available for performing the connection (ON)/disconnection (OFF) of the electronic clutch.

Signal name	Edge type	Overview
Slave axis clutch ON request	Level	Clutch is connected (ON) by turning ON the "slave axis clutch ON request" signal. Clutch is connected (OFF) by turning OFF the "slave axis clutch ON request" signal.  * The slave axis clutch OFF request signal is not used. When the edge selection is "Level", the slave axis clutch OFF request is invalid.
	ON OFF	Clutch is connected (ON) by detecting the leading edge of the "slave axis clutch ON request" signal.
	ON OFF	Clutch is connected (ON) by detecting the trailing edge of the "slave axis clutch ON request" signal.
Slave axis clutch OFF request	Invalid	The clutch control by the "slave axis clutch OFF request" is not performed.
	ON OFF	Clutch is disconnected (OFF) by detecting the leading edge of the "slave axis clutch OFF request" signal.
	ON OFF	Clutch is disconnected (OFF) by detecting the trailing edge of the "slave axis clutch OFF request" signal.

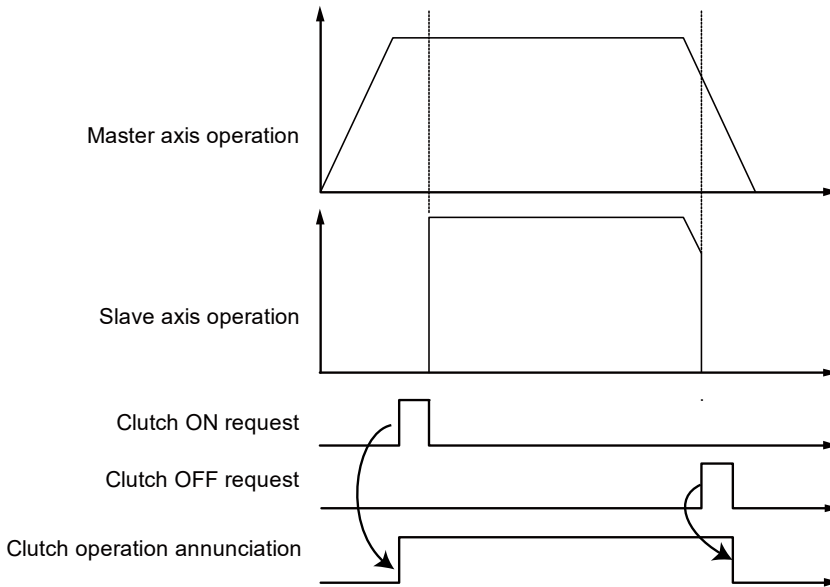

(Note): The above figure shows the case when selecting "Direct" for the connection method and "Leading edge" for the clutch ON and OFF requests.

■ Clutch request signal

Signal name	Real axis			
	Axes 1-16	Axes 17-32	Axes 33-48	Axes 49-64
Slave axis clutch ON request	UM001E6	UM001E7	UM001E8	UM001E9
Slave axis clutch OFF request	UM001EC	UM001ED	UM001EE	UM001EF
Slave axis clutch operation annunciation	UM000D8	UM000D9	UM000DA	UM000DB

(Note 1): Flags or request signals for 16 axes are allocated to each unit memory (1 word). When the value of each bit is 1, it turns on. When the value of each bit is 0, it turns off.

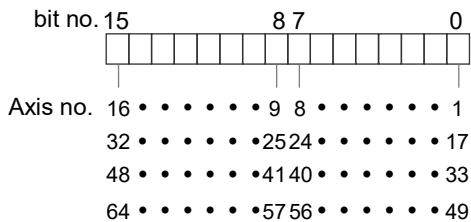

### 9.5.4 Connection Method of Electronic Clutch

The electronic clutch function connects the clutch to start operating the slave axes and disconnects the clutch to stop operating the slave axes, the acceleration or deceleration of the slave axes can be set as shown below.

■ **Direct method**

This method detects the connection (ON) or disconnection (OFF) of the clutch to adjust the operating speed of the master axis to coincide with that of the slave axes. In the direct method, the speed of the slave axes with the clutch connected (ON) or disconnected (OFF) coincides with the operating speed of the master axis with the acceleration and deceleration time set to 0.

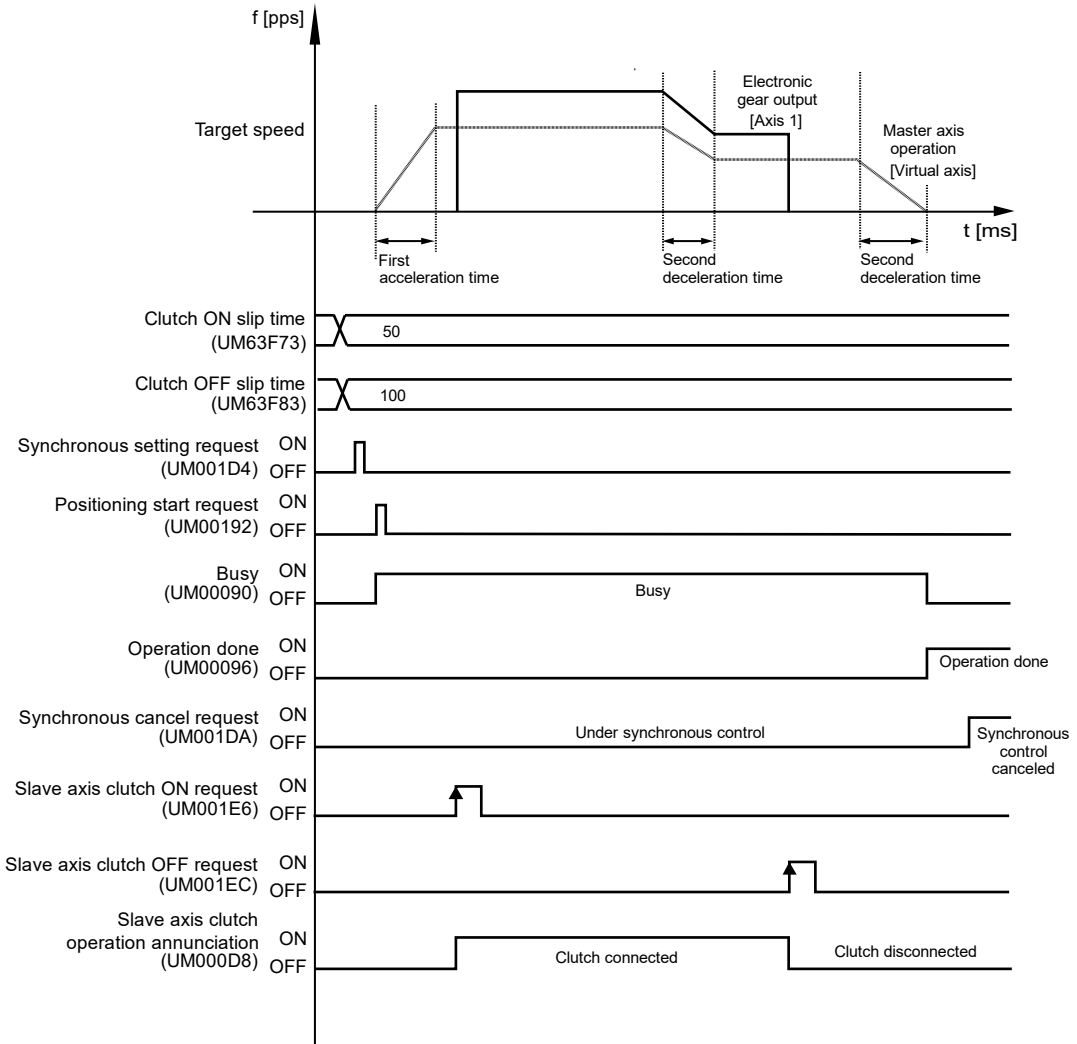

■ Slip method

This method detects the connection (ON) or disconnection (OFF) of the clutch and set the slip time to acceleration time and deceleration time so that the operating speed of the slave axes to follow the operation speed of the master axis. The acceleration/deceleration method when the clutch is connected (ON) or disconnected (OFF) is the linear acceleration/deceleration.

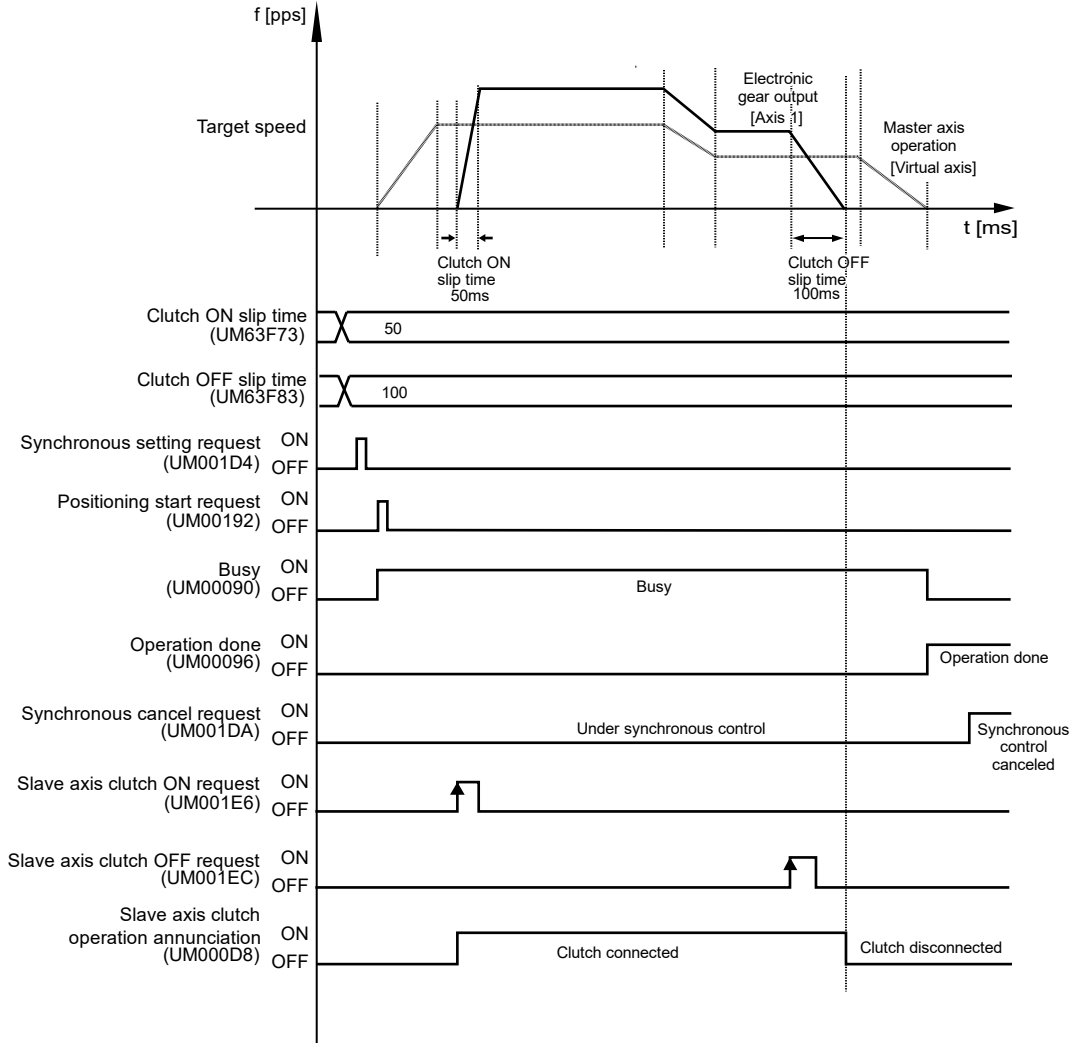



### 9.5.5 Phase Specification Clutch OFF Function

■ What is phase specification clutch OFF function?

- The "phase specification clutch OFF function" is a function for disconnecting an electronic clutch (OFF) at an arbitrarily specified phase. For stopping or starting at the same phase repeatedly, the control without variance can be performed. This function is available since FP7 MC Unit Ver. 1.20.
- However, select "Direct" for the clutch OFF method. When selecting "Slip", variation in stop position is caused because it stops after the elapse of a slip time from a stop phase arbitrarily set.

■ Clutch OFF method (Direct)

When performing the OFF request by the I/O signal, the clutch off operation will be executed regardless of phase.

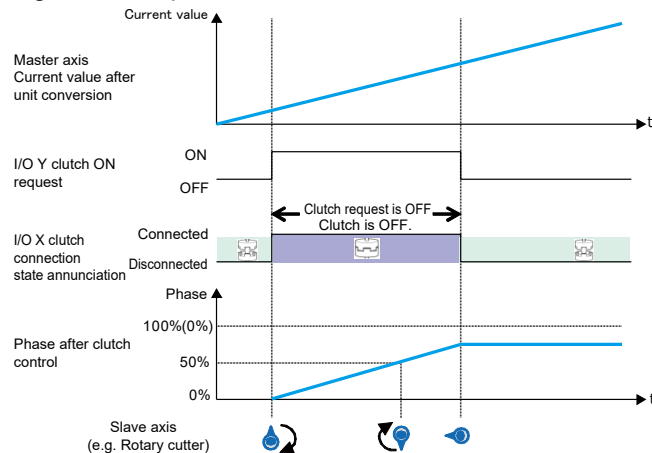

Using the "phase specification clutch off function" disconnects a clutch when the phase reaches the set phase (0%) after the clutch off request by the I/O signal.

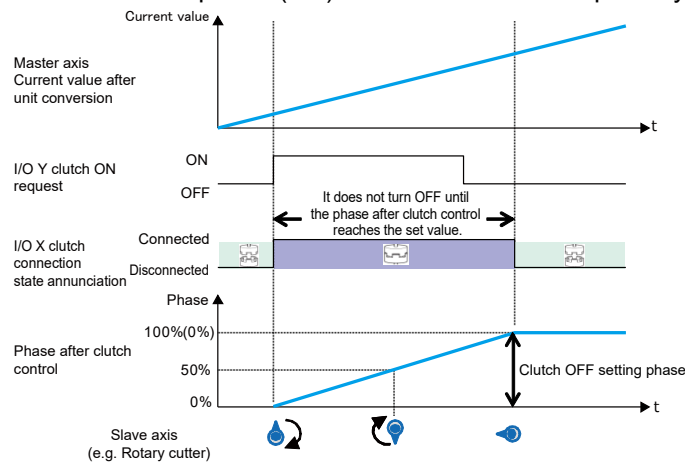

(Note 1): The above figure shows the case that the both clutch ON request and OFF request are set to "Level". Also, either "Leading edge" or "Trailing edge" can be selected.

(Note 2): The above figure shows the case that the clutch off setting ratio is set to "0%". It can be set to 0 to 99%.

■ Clutch OFF method (Slip)

When setting "Slip" for the clutch OFF method, the deceleration stop is performed after a specified slip time from the time that the phase reaches the clutch off setting ratio. To stop the motors at the phase of a set ratio, set the clutch OFF method to "Direct".

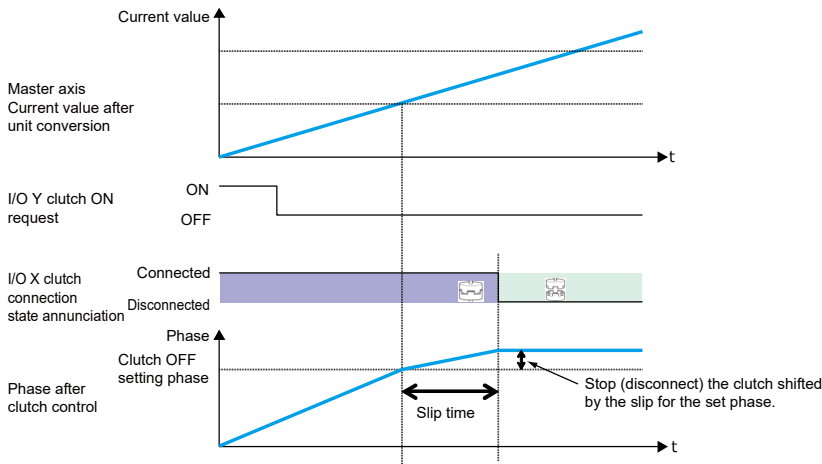

■ Precautions for operation characteristics

When the clutch OFF trigger signal is detected at a phase larger than the set clutch OFF setting ratio (0 to 99%), the clutch will be disconnected at the next time the signal reaches the set phase.

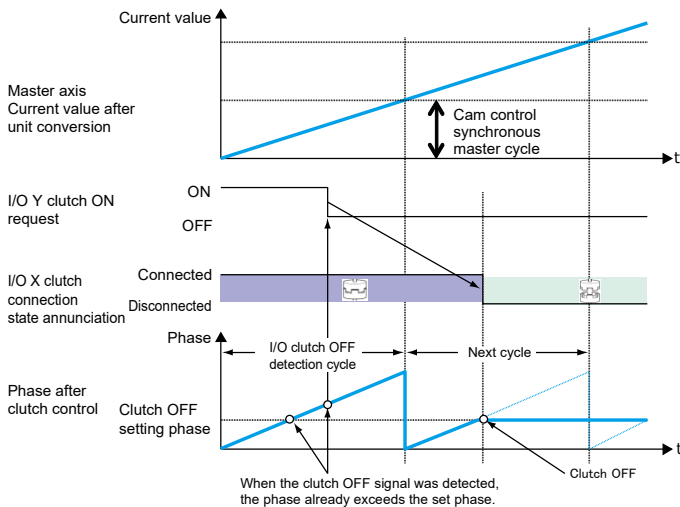

## 9.6 Electronic Cam Function

### 9.6.1 Overview of Electronic Cam Function

#### ■ What is Electronic cam function?

The electronic cam function uses a preset cam pattern, determines the movement amount of the slave axes according to the operation of the master axis (phase information) and cam pattern, and outputs the movement amount. The cam pattern uses one rotation of the master axis as an operation reference, based on which the displacement value of the slave axes in each phase (rotation angle) is defined in the cam pattern settings of CMI.

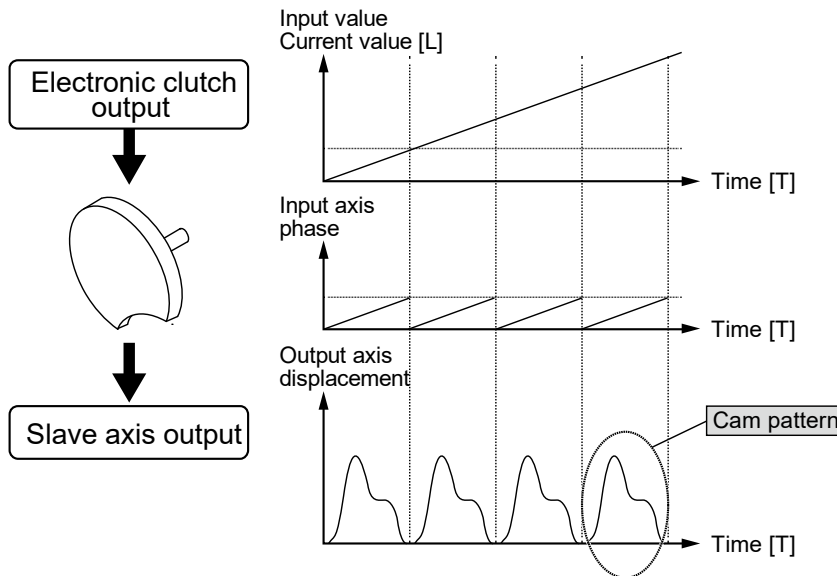

#### ■ Cam pattern

The cam pattern uses one rotation of the master axis as an operation reference, based on which the displacement of the slave axes in each phase (rotation angle) is defined. The cam pattern is defined with the phase (rotation angle) of the master axis on the X-axis and the displacement on the Y-axis in percent. The cam pattern is set in the "Cam pattern settings" menu of CMI.

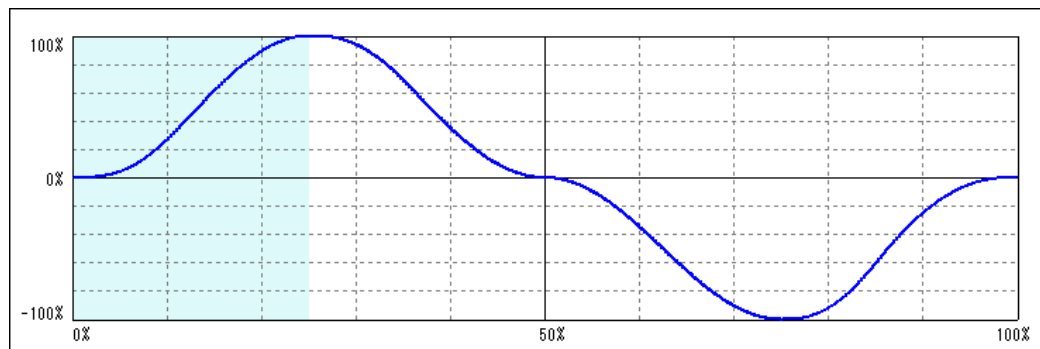

■ **Cam pattern specifications**

Setting item	Specifications			
Resolution	1024, 2048, 4096, 8192, 16384, 32768			
No. of cam patterns		AFP7MC16EC	AFP7MC32EC	AFP7MC64EC
	Resolutions of 1024, 2048, 4096, and 8192:	64	128	256
	Resolution of 16384:	32	64	128
	Resolution of 32768:	16	32	64
Section setting	100 %/cycle, 20 sections max.			
Displacement setting	100 % setting			
Cam curve	Constant speed / Constant acceleration / Simple harmonic / Cycloid /Modified trapezoid / Modified sine / Modified constant speed / Asymmetric cycloid / Asymmetric modified trapezoid / Trapecloid / One-dwell cycloid, m=1 / One-dwell cycloid, m=2/3 / One-dwell modified trapezoid, m=1 / One dwell modified trapezoid, Ferguson / One-dwell modified trapezoid, m=2/3 / One-dwell modified sine / One-dwell trapezoid / No-dwell modified trapezoid / No-dwell constant speed / NC2 curve			
Adjustment function	Function to adjust the displacement of desired point data: Max. 1,000 points (in units of cam data)			
Shift function	Phase shift in created cam data: 0 to 100%			
Display	Displacement / Speed / Acceleration / Jerk The display can be changed arbitrarily by the check box of CMI.			



◆ **KEY POINTS**

- **The advance angle correction function has been added, which corrects the response delay of cam output axis. This function is available since FP7 MC Unit Ver. 1.20. For details, refer to "9.5.5 Phase Specification Clutch OFF Function".**

### 9.6.2 Types and Contents of Setting Parameters

For using the electronic cam, set the following parameters in the "Synchronous parameter settings" menu.

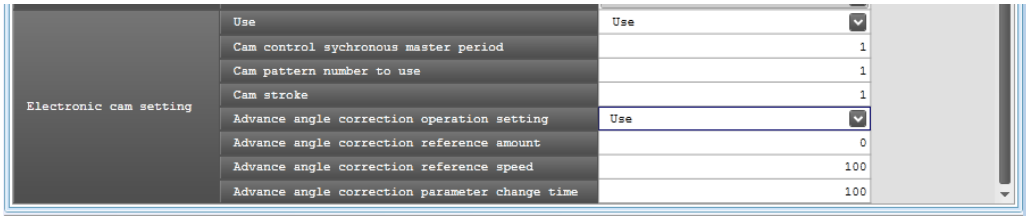

Parameter name	Default	Description
Electronic cam setting - Use	Not use	Select the operation of the electronic cam. When selecting "Not use", the electronic cam function does not operate and the output from the electronic clutch is output. Use / Not use
Cam pattern	—	The cam pattern is the most fundamental setting for using the electronic cam function. The cam pattern is set in the cam pattern settings window in the FPWIN GR7 Configuration screen. FP7 MC Unit converts cam patterns into point data based on the preset cam curves and resolutions.
Cam control synchronous master cycle	1	Set the number of pulses corresponding to the all phases of the cam pattern used (one-rotation data on the master axis). Range: 1 to 2147483647
Used cam pattern number	1	Specify the cam pattern number to be used from cam patterns created. Range: 1 to 256
Cam stroke amount	1	Set the number of pulses corresponding to the total displacement (100%) of the cam pattern to use. Range: 1 to 2147483647
Advance angle correction operation setting	Not use	Select the use or non-use of the advance angle correction function.
Reference amount	0	The unit follows the unit system of the master axis. Range: -2147483648 to +2147483647 (The decimal point position is based on unit systems.)
Reference speed	100	The unit follows the unit system of the master axis. Range: 1 to 2,147,483,647 Any other settings will be errors. The ranges vary depending on the unit settings as below. Pulse: 1 to 2,147,483,647 pps µm: 1 to 2,147,483,647 µm/s inch: 0.001 to 2,147,483.647 inch/s degree: 0.001 to 2,147,483.647 rev/s
Parameter change time	100	Range: 1 to 10000 ms

(Note 1): The advance angle correction function is available since FP7 MC Unit Ver.1.20.

### 9.6.3 Cam Pattern Setting Method

The following procedure is explained on the condition that CMI has already started.

#### ■ Starting Cam pattern setting screen

Select "Parameter" > "Cam pattern settings" from the menu bar. The cam patter setting screen is displayed. A blank screen is displayed for a new file, and a setting of cam pattern 1 is displayed when data already exists.

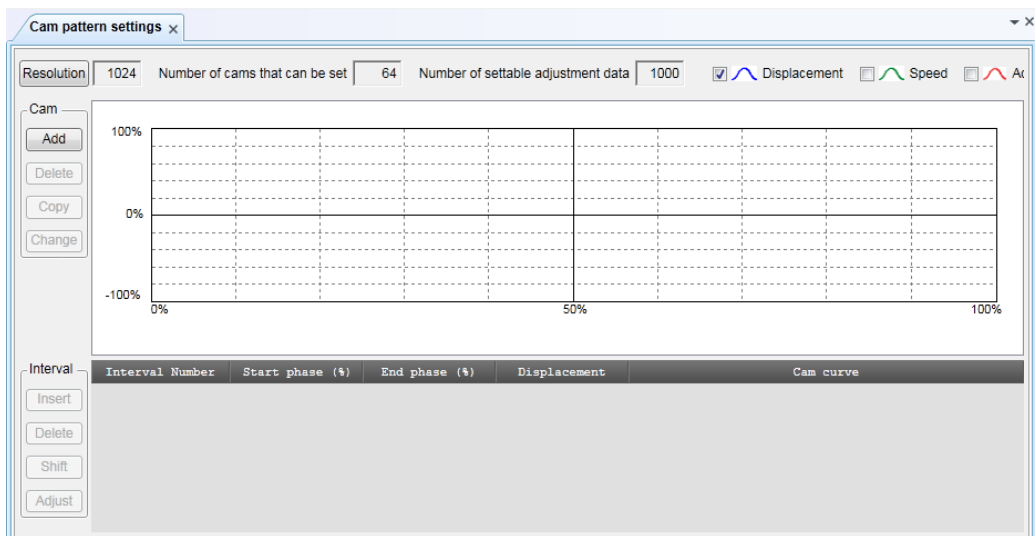

#### ■ Resolution setting

Press the [Resolution] button on the Cam Pattern screen. The Resolution Settings screen will be displayed. Select the desired resolution and press the [OK] button.

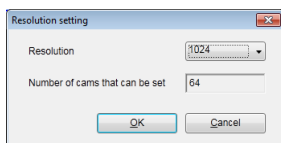

Resolution	Cam setting range		
	AFP7MC16EC	AFP7MC32EC	AFP7MC64EC
1024, 2048, 4096, 8192	1 to 64	1 to 128	1 to 256
16384	1 to 32	1 to 64	1 to 128
32768	1 to 16	1 to 32	1 to 64



## ◆ KEY POINTS

- The resolution is valid for all cam patterns. You cannot set a different resolution per cam pattern.
- The number of cam patterns available varies with each resolution. The current resolution cannot be changed to a new resolution if the number of cam patterns already set exceeds the number of cam patterns available for the new resolution. Delete the cam pattern and change the resolution.

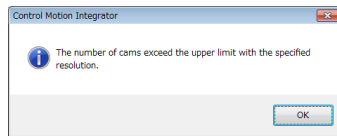

### ■ Making/duplicating new cam pattern

The Cam no. Selection screen is displayed by pressing the [Add] button from the Cam field. Select the desired can number and press the [OK] button.

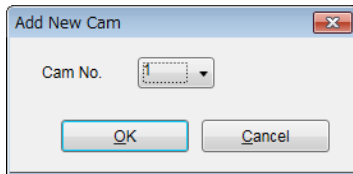

Cam patterns can be copied. Press the "Copy" button and select the cam pattern numbers of copy destination and copy source.

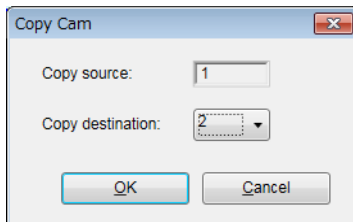

For changing the cam number, press the "Change" button and select a cam number after the change.

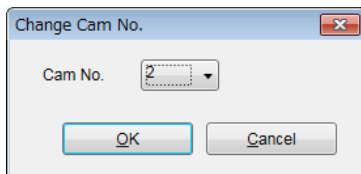

(Note): Cam pattern numbers that have been already set cannot be set.

## ■ Cam pattern setting

Press the "Insert" button from the "Section" field. Set the start phase, and press the [OK] button. In the default condition, only one section whose phase is 0 to 100% can be set for the cam pattern. By setting the start phase, the above section is divided into multiple sections.

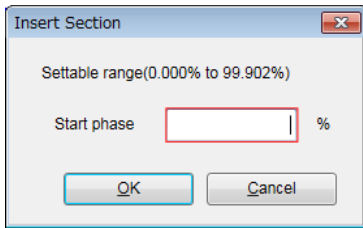

The background of the selected sections is displayed in white, and the background of the unselected sections is displayed in gray.

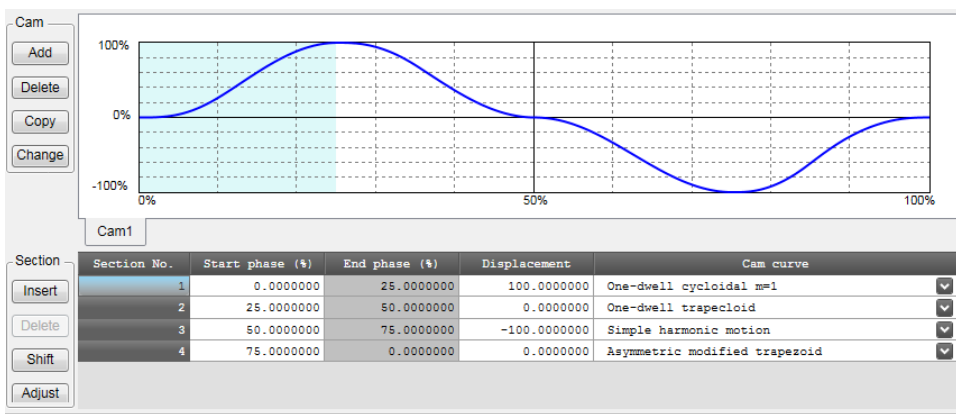

## ◆ NOTES

The start phase may not be a specified phase value due to the relation with resolution.



### ■ Edit of cam table

Data of created cam tables is edited.

Set the following items in each set section;

- Start phase (%)
- Displacement (%)
- Cam curve

The cam curve changes according to the settings.

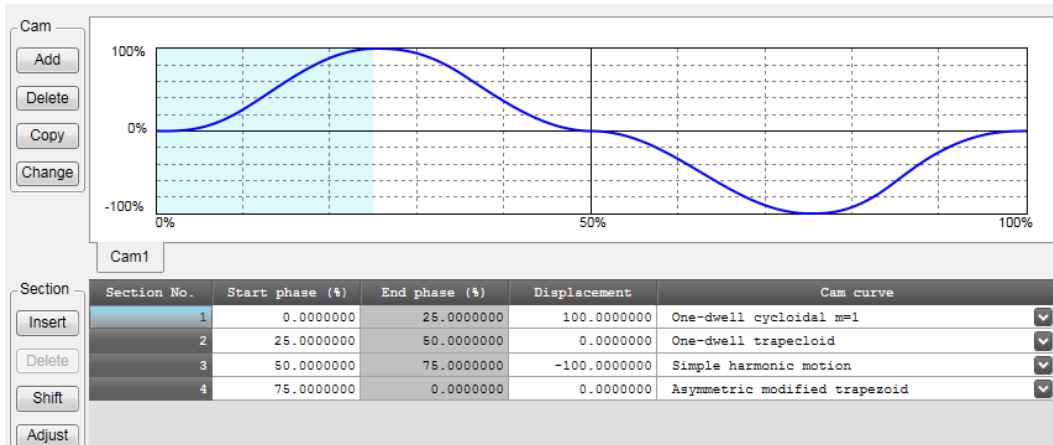

### ◆ KEY POINTS

- The end phase cannot be set. The end phase is automatically changed when changing the start phase.
- Do not make a rapid change in displacement for the set cam curve. In the case of rapid displacement, a motor may not be able to follow the output.
- Also, set the 0% and 100% of the phase to be the same displacement.

■ Confirmation of cam table

Confirm the set cam table (cam curve). In the synchronous control, slave axes operate following the cam curve. Therefore, a motor may not be able to follow the output if the change in the cam curve is rapid. For the change in the cam curve, not only the information on displacement but also the information such as acceleration information is important. In the cam table setting screen, the following information except displacement can be displayed.

Display item	Description
Displacement	This is set in the cam table.
Speed	The operation speed of the cam table with a set displacement amount is displayed by relative values.
Acceleration	Accelerations at each phase are displayed. Care is necessary in the area where acceleration largely changes as a rapid change in the speed occurs.
Jerk	It is obtained by differentiating acceleration by a time. It indicates a rate of change of acceleration.

Each display item can be set by checking the following check boxes in the cam table setting screen. Refer to each display items, and change the cam table settings.

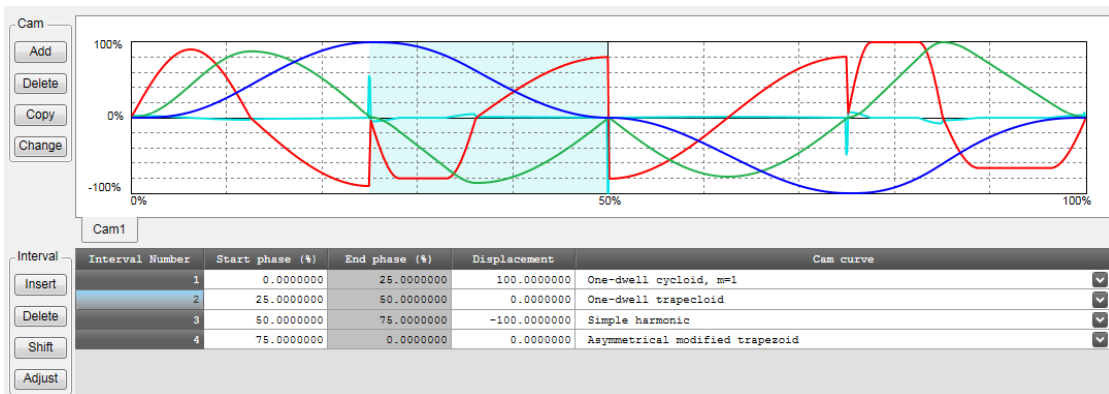
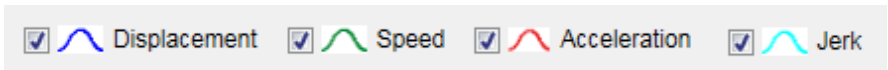

■ Adjustment of cam table

There is a function to finely adjust the data of set cam curves in the cam table setting screen. Rapid change can be lessened by performing find adjustment of the set cam data using the adjustment function. To perform adjustment, select a section number to be adjusted and press the [Adjust] button. The adjustment screen is displayed. The adjustment screen shows the table of the part corresponding to the specified section number among sections divided by the resolution that all sections (0 to 100%) are set.

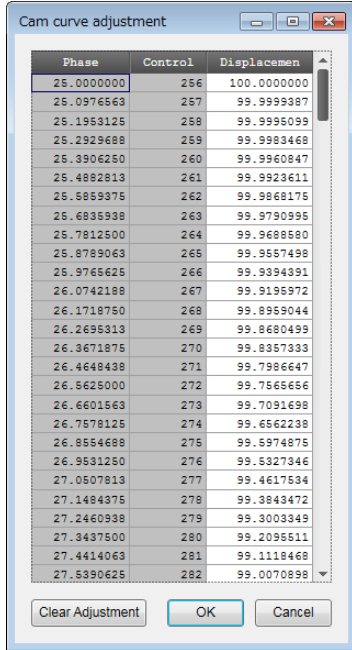

Select the data of a phase (control point) you want to adjust and change the displacement data. Select "OK" to reflect the adjustment. Select "Clear Adjustment" to clear the set adjustment data. The cam curve of the section number that the adjustment was executed is displayed in red so that it can be identified.

Interval Number	Start phase (%)	End phase (%)	Displacement	Cam curve
1	0.0000000	25.0000000	100.0000000	One-dwell cycloid, m=1
2	25.0000000	50.0000000	0.0000000	One-dwell trapezoid
3	50.0000000	75.0000000	-100.0000000	Simple harmonic
4	75.0000000	0.0000000	0.0000000	Asymmetrical modified trapezoid

■ Shift of cam table

Although created cam patterns are defined for the phases of 0 to 100%, phases used as a reference for created cam patterns may be different in actual operations. The shift of cam table is a function to set the phase of the position of current value coordinate system 0 to be a percentage of a created cam pattern.

Image of shifting electronic cam

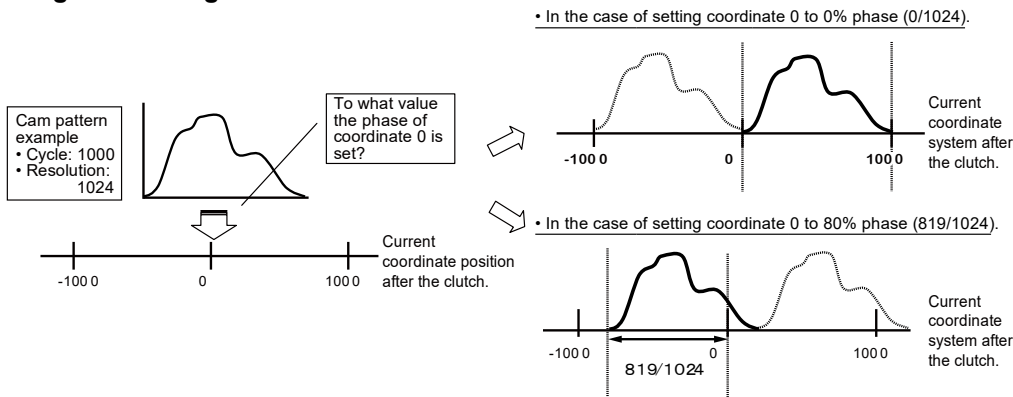

Select Shift from "Section", and set a shift amount.

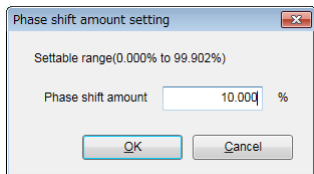

The created cam pattern is shifted by 10% and the display is updated.

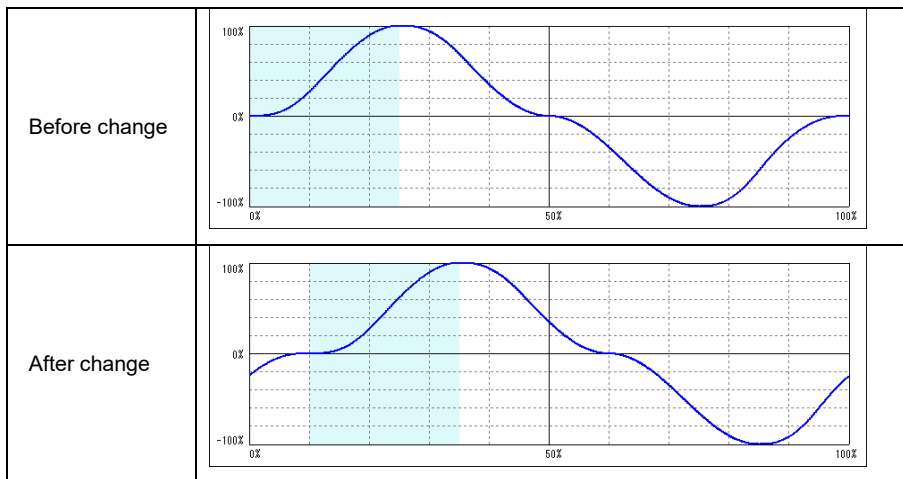

■ Storage of cam table

The created cam table is stored as a file together with other parameter data set by CMI.

### 9.6.4 Editing Cam Patterns by User Programs

Cam patterns of data in the cam pattern setting area used for electronic cams can be edited by using the cam pattern editing area with user programs. This function is available since FP7 MC Unit Ver.1.2.

- There are two operations which are reading cam tables and rewriting cam tables in the cam pattern editing.
- These operations are performed using the "cam pattern editing area" (UM66F40 to UM66F97), cam table reading request (Y8) and cam table rewriting request (Y9) of unit memories.

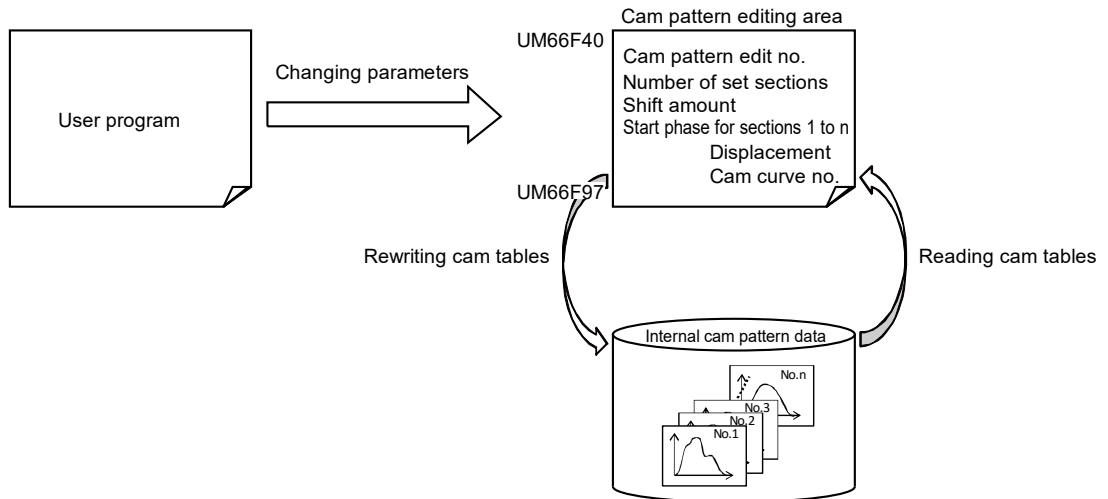

The parameters used for the cam pattern editing with user programs are as follows.

Axis no.	Unit memory no. (Hex)	Name	Default	Unit	Setting range and description																					
-	UM 66F40	Cam pattern no.	U0		<p>When reading: Set a cam pattern number to be read out. When rewriting: Set a cam pattern number to be written.</p> <table border="1"> <thead> <tr> <th rowspan="2">bit</th> <th rowspan="2">Pattern resolution</th> <th colspan="3">Setting range</th> </tr> <tr> <th>Axis 16</th> <th>Axis 32</th> <th>Axis 64</th> </tr> </thead> <tbody> <tr> <td rowspan="3">15-0</td> <td>1024,2048,4096,8192</td> <td>1 to 64</td> <td>1 to 128</td> <td>1 to 256</td> </tr> <tr> <td>16384</td> <td>1 to 32</td> <td>1 to 64</td> <td>1 to 128</td> </tr> <tr> <td>32768</td> <td>1 to 16</td> <td>1 to 32</td> <td>1 to 64</td> </tr> </tbody> </table> <p>Any other settings will be errors.</p>	bit	Pattern resolution	Setting range			Axis 16	Axis 32	Axis 64	15-0	1024,2048,4096,8192	1 to 64	1 to 128	1 to 256	16384	1 to 32	1 to 64	1 to 128	32768	1 to 16	1 to 32	1 to 64
bit	Pattern resolution	Setting range																								
		Axis 16	Axis 32	Axis 64																						
15-0	1024,2048,4096,8192	1 to 64	1 to 128	1 to 256																						
	16384	1 to 32	1 to 64	1 to 128																						
	32768	1 to 16	1 to 32	1 to 64																						
-	UM 66F41	Reserved for system	-		-																					
-	UM 66F42	No. of cam pattern setting sections	U0	Section	<p>When reading, the number of setting sections of the read cam pattern table is stored. When rewriting, the cam curve number of the rewritten cam pattern table is set.</p> <table border="1"> <thead> <tr> <th>bit</th> <th>Name</th> <th>Description</th> </tr> </thead> <tbody> <tr> <td>15-0</td> <td>No. of cam pattern setting sections</td> <td>Setting range: 1 to 20 (sections) Any other settings will be errors.</td> </tr> </tbody> </table>	bit	Name	Description	15-0	No. of cam pattern setting sections	Setting range: 1 to 20 (sections) Any other settings will be errors.															
bit	Name	Description																								
15-0	No. of cam pattern setting sections	Setting range: 1 to 20 (sections) Any other settings will be errors.																								
-	UM 66F43	Shift amount	U0	0.01%	<p>When reading, the shift amount of the read cam pattern table is stored. When rewriting, the shift amount of the rewritten cam pattern table is stored.</p> <table border="1"> <thead> <tr> <th>bit</th> <th>Name</th> <th>Description</th> </tr> </thead> <tbody> <tr> <td>15-0</td> <td>Shift amount</td> <td>Range: 0 to 100.00 (%) Any other settings will be errors.</td> </tr> </tbody> </table>	bit	Name	Description	15-0	Shift amount	Range: 0 to 100.00 (%) Any other settings will be errors.															
bit	Name	Description																								
15-0	Shift amount	Range: 0 to 100.00 (%) Any other settings will be errors.																								

Axis no.	Unit memory no. (Hex)	Name	Default	Unit	Setting range and description						
-	UM 66F44	Start phase of section 1	U0	0.01%	<p>When reading, the start phase in the section 1 of the read cam pattern table is stored. The read value is always 0. When rewriting, the start phase in the section 1 of the rewritten cam pattern table is set. When any value other than 0 is set in the section 1, it cannot be rewritten correctly.</p> <table border="1"> <thead> <tr> <th>bit</th> <th>Name</th> <th>Description</th> </tr> </thead> <tbody> <tr> <td>15-0</td> <td>Start phase of section 1</td> <td>Range: 0 to 10000 (0% to 100.00%) Any other settings will be errors.</td> </tr> </tbody> </table> <p>When reading, the numbers beyond the third decimal point is truncated and the result is stored. When rewriting, the numbers beyond the third decimal point are calculated in the unit and the result is registered.</p>	bit	Name	Description	15-0	Start phase of section 1	Range: 0 to 10000 (0% to 100.00%) Any other settings will be errors.
bit	Name	Description									
15-0	Start phase of section 1	Range: 0 to 10000 (0% to 100.00%) Any other settings will be errors.									
-	UM 66F45	Displacement of section 1	K0	0.01%	<p>When reading, the displacement in the section 1 of the read cam pattern table is stored. When rewriting, the displacement in the section 1 of the rewritten cam pattern table is set.</p> <table border="1"> <thead> <tr> <th>bit</th> <th>Name</th> <th>Description</th> </tr> </thead> <tbody> <tr> <td>15-0</td> <td>Displacement of section 1</td> <td>Range: -10000 to +10000 (-100.00% to +100.00%) Any other settings will be errors.</td> </tr> </tbody> </table> <p>When reading, the numbers beyond the third decimal point is truncated and the result is stored. When rewriting, the numbers beyond the third decimal point are calculated in the unit and the result is registered.</p>	bit	Name	Description	15-0	Displacement of section 1	Range: -10000 to +10000 (-100.00% to +100.00%) Any other settings will be errors.
bit	Name	Description									
15-0	Displacement of section 1	Range: -10000 to +10000 (-100.00% to +100.00%) Any other settings will be errors.									
-	UM 66F46	Cam curve of section 1	U0	-	<p>When reading, the cam curve of the read cam pattern table is stored. When rewriting, the cam curve of the rewritten cam pattern table is set.</p> <table border="1"> <thead> <tr> <th>bit</th> <th>Name</th> <th>Description</th> </tr> </thead> <tbody> <tr> <td>15-0</td> <td>Cam curve setting of section 1</td> <td>10: Constant speed 11: Constant acceleration 12: Simple harmonic motion 22: Cycloid 25: Modified trapezoid 26: Modified sine 27: Modified uniform velocity 33: Asymmetric cycloid 34: Asymmetric modified trapezoid 35: Trapezoid 43: One-dwell cycloid m=1 44: One-dwell cycloid m=2/3 45: One-dwell modified trapezoid m=1 46: One-dwell modified trapezoid (Ferguson) 47: One-dwell modified trapezoid m=2/3 48: One-dwell modified sine 49: One-dwell trapezoid No-dwell modified trapezoid 52: No-dwell modified uniform velocity 92: NC2 curve Any other settings will be errors.</td> </tr> </tbody> </table>	bit	Name	Description	15-0	Cam curve setting of section 1	10: Constant speed 11: Constant acceleration 12: Simple harmonic motion 22: Cycloid 25: Modified trapezoid 26: Modified sine 27: Modified uniform velocity 33: Asymmetric cycloid 34: Asymmetric modified trapezoid 35: Trapezoid 43: One-dwell cycloid m=1 44: One-dwell cycloid m=2/3 45: One-dwell modified trapezoid m=1 46: One-dwell modified trapezoid (Ferguson) 47: One-dwell modified trapezoid m=2/3 48: One-dwell modified sine 49: One-dwell trapezoid No-dwell modified trapezoid 52: No-dwell modified uniform velocity 92: NC2 curve Any other settings will be errors.
bit	Name	Description									
15-0	Cam curve setting of section 1	10: Constant speed 11: Constant acceleration 12: Simple harmonic motion 22: Cycloid 25: Modified trapezoid 26: Modified sine 27: Modified uniform velocity 33: Asymmetric cycloid 34: Asymmetric modified trapezoid 35: Trapezoid 43: One-dwell cycloid m=1 44: One-dwell cycloid m=2/3 45: One-dwell modified trapezoid m=1 46: One-dwell modified trapezoid (Ferguson) 47: One-dwell modified trapezoid m=2/3 48: One-dwell modified sine 49: One-dwell trapezoid No-dwell modified trapezoid 52: No-dwell modified uniform velocity 92: NC2 curve Any other settings will be errors.									

## Automatic Operation (Synchronous Control)

Axis no.	Unit memory no. (Hex)	Name	Default	Unit	Setting range and description
-	UM 66F47	Reserved for system	-	-	-
-	UM 66F48	Start phase of section 2	U0	0.01%	Just like the area for the section 1, set the start phase, displacement and cam curve.
-	UM 66F49	Displacement of section 2	K0	0.01%	
-	UM 66F4A	Cam curve of section 2	U0	-	
-	UM 66F4B	Reserved for system	-	-	
-	UM 66F4C	Start phase of section 3	U0	0.01%	
-	UM 66F4D	Displacement of section 3	K0	0.01%	
-	UM 66F4E	Cam curve of section 3	U0	-	
-	UM 66F4F	Reserved for system	-	-	
-	UM 66F50	Start phase of section 4	U0	0.01%	
-	UM 66F51	Displacement of section 4	K0	0.01%	
-	UM 66F52	Cam curve of section 4	U0	-	
-	UM 66F53	Reserved for system	-	-	
-	UM 66F54	Start phase of section 5	U0	0.01%	
-	UM 66F55	Displacement of section 5	K0	0.01%	
-	UM 66F56	Cam curve of section 5	U0	-	
-	UM 66F57	Reserved for system	-	-	



Axis no.	Unit memory no. (Hex)	Name	Default	Unit	Setting range and description
-	UM 66F58	Start phase of section 6	U0	0.01%	Just like the area for the section 1, set the start phase, displacement and cam curve.
-	UM 66F59	Displacement of section 6	K0	0.01%	
-	UM 66F5A	Cam curve of section 6	U0	-	
-	UM 66F5B	Reserved for system	-	-	
-	UM 66F5C	Start phase of section 7	U0	0.01%	
-	UM 66F5D	Displacement of section 7	K0	0.01%	
-	UM 66F5E	Cam curve of section 7	U0	-	
-	UM 66F5F	Reserved for system	-	-	
-	UM 66F60	Start phase of section 8	U0	0.01%	
-	UM 66F61	Displacement of section 8	K0	0.01%	
-	UM 66F62	Cam curve of section 8	U0	-	
-	UM 66F63	Reserved for system	-	-	
-	UM 66F64	Start phase of section 9	U0	0.01%	
-	UM 66F65	Displacement of section 9	K0	0.01%	
-	UM 66F66	Cam curve of section 9	U0	-	
-	UM 66F67	Reserved for system	-	-	

## Automatic Operation (Synchronous Control)

Axis no.	Unit memory no. (Hex)	Name	Default	Unit	Setting range and description
-	UM 66F68	Start phase of section 10	U0	0.01%	Just like the area for the section 1, set the start phase, displacement and cam curve.
-	UM 66F69	Displacement of section 10	K0	0.01%	
-	UM 66F6A	Cam curve of section 10	U0	-	
-	UM 66F6B	Reserved for system	-	-	
-	UM 66F6C	Start phase of section 11	U0	0.01%	
-	UM 66F6D	Displacement of section 11	K0	0.01%	
-	UM 66F6E	Cam curve of section 11	U0	-	
-	UM 66F6F	Reserved for system	-	-	
-	UM 66F70	Start phase of section 12	U0	0.01%	
-	UM 66F71	Displacement of section 12	K0	0.01%	
-	UM 66F72	Cam curve of section 12	U0	-	
-	UM 66F73	Reserved for system	-	-	
-	UM 66F74	Start phase of section 13	U0	0.01%	
-	UM 66F75	Displacement of section 13	K0	0.01%	
-	UM 66F76	Cam curve of section 13	U0	-	
-	UM 66F77	Reserved for system	-	-	

Axis no.	Unit memory no. (Hex)	Name	Default	Unit	Setting range and description
-	UM 66F78	Start phase of section 14	U0	0.01%	Just like the area for the section 1, set the start phase, displacement and cam curve.
-	UM 66F79	Displacement of section 14	K0	0.01%	
-	UM 66F7A	Cam curve of section 14	U0	-	
-	UM 66F7B	Reserved for system	-	-	
-	UM 66F7C	Start phase of section 15	U0	0.01%	
-	UM 66F7D	Displacement of section 15	K0	0.01%	
-	UM 66F7E	Cam curve of section 15	U0	-	
-	UM 66F7F	Reserved for system	-	-	
-	UM 66F80	Start phase of section 16	U0	0.01%	
-	UM 66F81	Displacement of section 16	K0	0.01%	
-	UM 66F82	Cam curve of section 16	U0	-	
-	UM 66F83	Reserved for system	-	-	
-	UM 66F84	Start phase of section 17	U0	0.01%	
-	UM 66F85	Displacement of section 17	K0	0.01%	
-	UM 66F86	Cam curve of section 17	U0	-	
-	UM 66F87	Reserved for system	-	-	

## Automatic Operation (Synchronous Control)

Axis no.	Unit memory no. (Hex)	Name	Default	Unit	Setting range and description
-	UM 66F88	Start phase of section 18	U0	0.01%	Just like the area for the section 1, set the start phase, displacement and cam curve.
-	UM 66F89	Displacement of section 18	K0	0.01%	
-	UM 66F8A	Cam curve of section 18	U0	-	
-	UM 66F8B	Reserved for system	-	-	
-	UM 66F8C	Start phase of section 19	U0	0.01%	
-	UM 66F8D	Displacement of section 19	K0	0.01%	
-	UM 66F8E	Cam curve of section 19	U0	-	
-	UM 66F8F	Reserved for system	-	-	
-	UM 66F90	Start phase of section 20	U0	0.01%	
-	UM 66F91	Displacement of section 20	K0	0.01%	
-	UM 66F92	Cam curve of section 20	U0	-	
-	UM 66F93	Reserved for system	-	-	
-	UM 66F94 -UM 66F97	Reserved for system	-	-	

■ Execution conditions of editing cam patterns

The editing of cam patterns by programs can be executed when the following three conditions are met.

- The synchronous operation is canceled for all axes. (The synchronous control cancel active annunciation flags of all axes are on.)
- All axes are stopped. (The operation done flags of all axes are on.)
- Parameters are set correctly.

When executing the cam table reading request (Y8) and cam table rewriting request (Y9) simultaneously, the cam table reading request (Y8) takes priority. In this case, the execution of the cam table rewriting request (Y9) results in the abnormal end, and the response code (HFF21) is stored in the unit memory (UM66F99).

■ Reading cam patterns

The procedure of reading cam pattern data in the cam pattern setting area is as follows.

①	Specify a cam pattern number you want to read for the cam pattern number (UM66F40).
②	Turn on the cam table reading request (Y8).
③	Check if the cam pattern reading result is "0000H (Normal end)" when the cam table reading done annunciation (X8) turns on

When the cam table reading done annunciation (X8) turns on, the setting data from the section 1 in the cam pattern editing area to the specified number of cam pattern setting sections will be read.

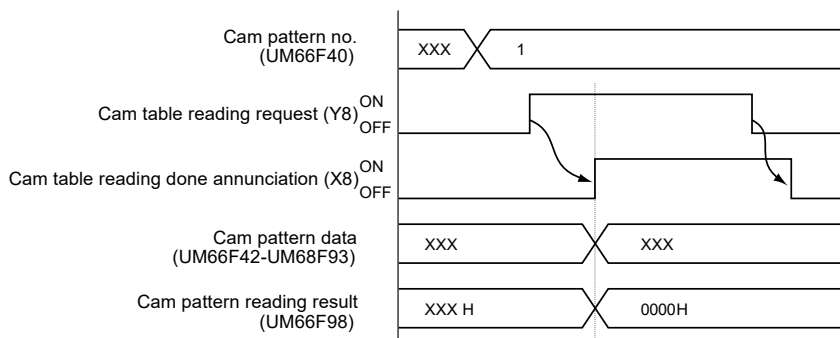
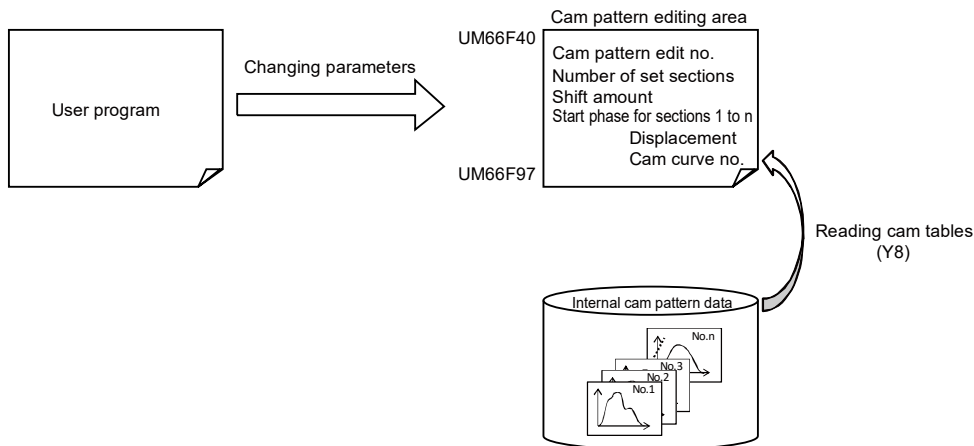

The cam pattern reading results are as follows.

Axis no.	Unit memory no. (Hex)	Name	Default	Unit	Setting range and description																				
-	UM 66F98	Cam pattern reading result	H0	-	<p>- The result of reading processing (response code) is stored.</p> <table border="1"> <thead> <tr> <th>Code</th> <th>Name</th> <th>Description</th> <th>Countermeasures</th> </tr> </thead> <tbody> <tr> <td>H0</td> <td>Normal end</td> <td>-</td> <td>-</td> </tr> <tr> <td>HFF01</td> <td>Cam pattern number setting error</td> <td>The cam pattern setting value is out of the settable range.</td> <td>Check the set value of the cam pattern number.</td> </tr> <tr> <td>HFF10</td> <td>Cam pattern reading not executable error 1</td> <td>An axis in synchronous operation exists.</td> <td>Cancel the synchronous operation and execute the reading.</td> </tr> <tr> <td>HFF11</td> <td>Cam pattern reading not executable error 2</td> <td>An operating axis exists.</td> <td>Execute the reading when no operating axis exists.</td> </tr> </tbody> </table>	Code	Name	Description	Countermeasures	H0	Normal end	-	-	HFF01	Cam pattern number setting error	The cam pattern setting value is out of the settable range.	Check the set value of the cam pattern number.	HFF10	Cam pattern reading not executable error 1	An axis in synchronous operation exists.	Cancel the synchronous operation and execute the reading.	HFF11	Cam pattern reading not executable error 2	An operating axis exists.	Execute the reading when no operating axis exists.
Code	Name	Description	Countermeasures																						
H0	Normal end	-	-																						
HFF01	Cam pattern number setting error	The cam pattern setting value is out of the settable range.	Check the set value of the cam pattern number.																						
HFF10	Cam pattern reading not executable error 1	An axis in synchronous operation exists.	Cancel the synchronous operation and execute the reading.																						
HFF11	Cam pattern reading not executable error 2	An operating axis exists.	Execute the reading when no operating axis exists.																						

■ **Rewriting cam patterns**

The procedure of rewriting cam pattern data in the cam pattern setting area is as follows.

①	Write the setting of the cam pattern you want to rewrite into the cam pattern editing area.
②	Specify a cam pattern number you want to rewrite for the cam pattern number (UM66F40).
③	Turn on the cam table rewriting request (Y9).
④	Check if the cam pattern rewriting result is "0000H (Normal end)" when the cam table rewriting done annunciation (X9) turns on.

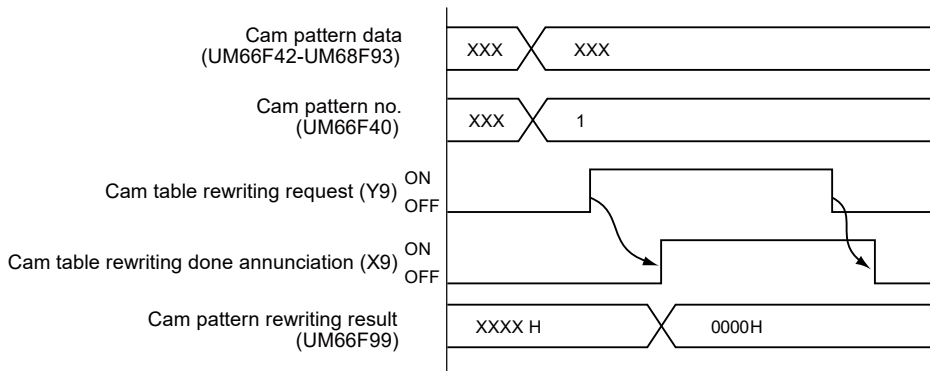
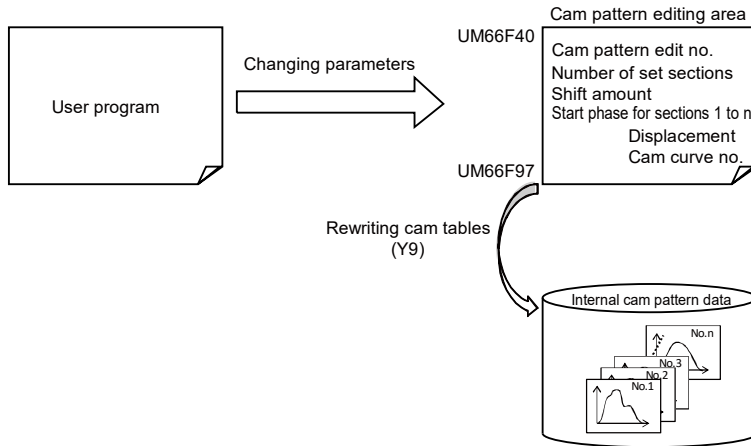

The cam pattern rewriting results are as follows.

Axis no.	Unit memory no. (Hex)	Name	Default	Unit	Setting range and description			
-	UM 66F99	Cam pattern rewriting result	0000H	-	The result of rewriting processing (response code) is stored.			
					Code	Name	Description	Countermeasures
					0000H	Normal end	-	-
					FF01H	Cam pattern no.	Setup error	The cam pattern setting value is out of the settable range.
					FF02H	Number of cam pattern setting sections setting error	The set number of cam pattern setting sections is out of the settable range.	Check the set number of setting sections.
					FF03H	Shift amount setting error	The set shift amount is out of the settable range.	Check the set value of the shift amount.
					FF04H	-	-	-
					FF05H	Start phase setting error 1	The set start phase is out of the settable range.	Check the set value of the start phase in each section.
					FF06H	Start phase setting error 2	The set start phase is the same as or smaller than the start phase of the previous section.	Check if the relation between the start phases of each section is (Start phase of section n-1) < (Start phase of section n).
					FF07H	Start phase setting error 3	The set start phase of the section 1 is not 0.	Always set the start phase of the section 1 to 0.
					FF08H-FF09H	-	-	-
					FF0AH	Displacement setting error	The set value of the displacement is out of the settable range.	Check the set value of the phase in each section.
					FF0BH	Cam curve no.	Setup error	The set cam curve number is out of the settable range.
					FF10H	Cam pattern reading not executable error 1	An axis in synchronous operation exists.	Cancel the synchronous operation and execute the reading.
					FF11H	Cam pattern reading not executable error 2	An operating axis exists.	Execute the reading when no operating axis exists.
					FF20H	Cam pattern rewriting not executable error 1	An axis in synchronous operation exists.	Cancel the synchronous operation and execute the rewriting.
					FF21H	Cam pattern rewriting not executable error 2	An operating axis exists.	Execute the rewriting when no operating axis exists.
					FF22H	Cam pattern rewriting not executable error 3	The reading request and rewriting request turned on simultaneously.	Check if the reading request and rewriting request do not turn on simultaneously.



■ Sample program

- The following program shows the case that the phase, displacement, and the type of curve are changed in the section 2 of the cam table number 2.
- The program is executed through five steps of (a) to (e).
- In this sample program, the positioning unit is installed in the slot number 1, and the starting word number is 10.

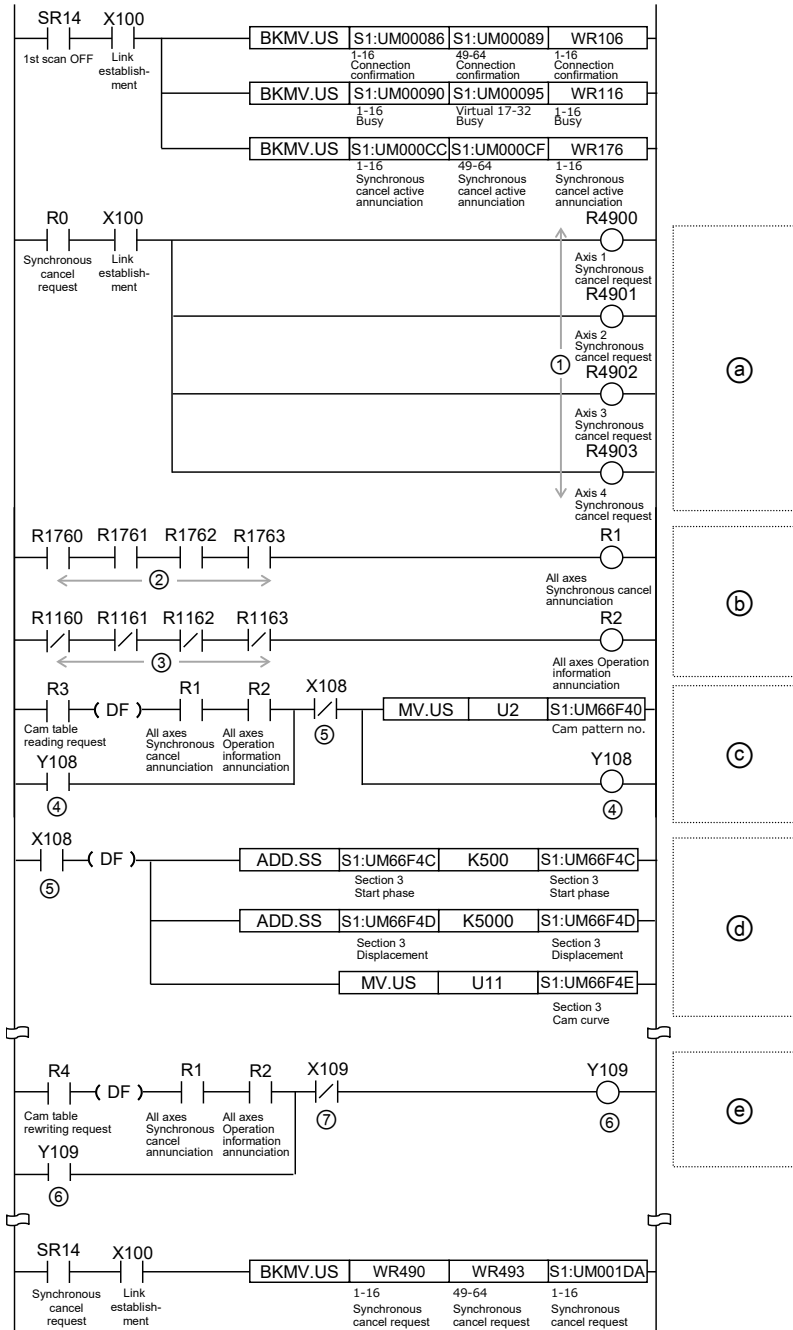

## Automatic Operation (Synchronous Control)

Code	Specified content	Description
Ⓐ	Canceling the synchronous control for all axes.	The cancellation of synchronous control for all axes is performed.
Ⓑ	Confirming the condition for execution permission.	It is confirmed that all axes are not in the synchronous control and are stopped.
Ⓒ	Starting the reading of cam tables.	A cam pattern number is specified, and the reading request (Y108) is made.
Ⓓ	Changing parameters in the cam table editing area.	The cam table data in the section 3 is edited after the completion of reading the cam table. In this example, the following three items are set. - Start phase: (Value before rewriting) + Addition of 5% - Displacement: (Value before rewriting) + Addition of 50% - Cam curve: Constant acceleration
Ⓔ	Starting the rewriting of cam tables.	Performs the rewriting to a specified cam pattern data.

Code	Signal name	Real axis				Virtual axis	
		Axes 1-16	Axes 17-32	Axes 33-48	Axes 49-64	Axes 1-16	Axes 17-32
①	Synchronous cancel request	UM01DA	UM01DB	UM01DC	UM01DD	-	-
②	Synchronous cancel active annunciation	UM00CC	UM00CD	UM00CE	UM00CF	-	-
③	Busy	UM0090	UM0091	UM0092	UM0093	-	-
④	Cam table reading request	Y108					
⑤	Cam table reading done annunciation	X108					
⑥	Cam table rewriting request	Y109					
⑦	Cam table rewriting done annunciation	X109					

(Note 1): I/O numbers vary according to the value of the "Starting word number" allocated to the unit. The I/O numbers in the above table are considered as the starting word number is 10.

### ■ Precautions for editing cam patterns by program

- Even if cam pattern data is rewritten by this function, the cam pattern data stored as Flash ROM data in FP7 MC Unit will not be updated.
- When the power supply is turned on, the data will be rewritten to the cam pattern data stored as Flash ROM data in FP7 MC Unit. As necessary, execute the rewriting of the cam pattern data again by a program.
- It is possible to confirm whether the cam pattern has been rewritten or not by the cam pattern update flags (UM66F9A to UM66FA9) in the unit memories using a program.
- When performing a reading request specifying an unregistered cam pattern number, all the read data will be "0".
- When performing a rewriting request while no cam pattern is registered (a resolution is undetermined), rewriting will be performed considering the resolution as 1024.
- Cam adjustment data set on CMI cannot be used. Also, when executing the rewriting, the adjustment data before the execution of rewriting will be initialized.

### ■ Precautions when using phase shift amount

- Specify the values when the phase shift amount is 0(%) for the parameter values of cam pattern (starting phase, displacement and cam curve).
- The starting phase of the section number 1 is 0(%). When any values other than 0(%), an error will occur. For starting phases after the section number 2, specify arbitrary starting phases. When reading and writing settings, the closest phase will be automatically calculated within the unit from the resolution.
- After setting the cam pattern when the phase shift amount is 0(%), set a phase shift amount. When reading and writing settings, the closest phase amount will be automatically calculated within the unit from the resolution.

For rewriting the cam pattern set on CMI to a user program, perform the following procedure.

(1) Record the phase shift amount specified on CMI.

(2) The phase shift amount has been added to the starting phase displayed on CMI. Set the phase shift amount to 0(%) to confirm the parameter values of cam pattern (starting phase, displacement, cam curve).

(3) Use the parameter values acquired in (2) on user programs. As for the starting phase, use values to two decimal places.

(4) Set the phase shift amount recorded in (1). As well as the starting phase, use values to two decimal places.

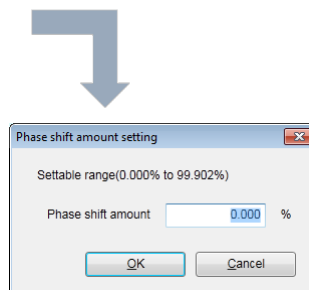
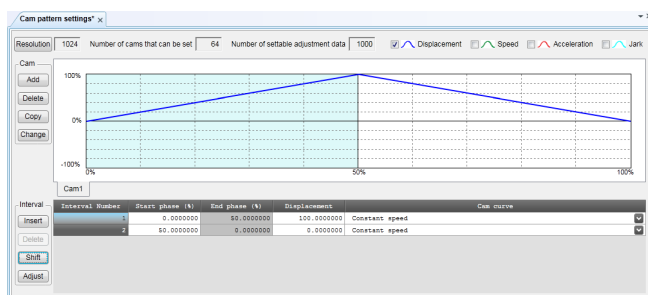
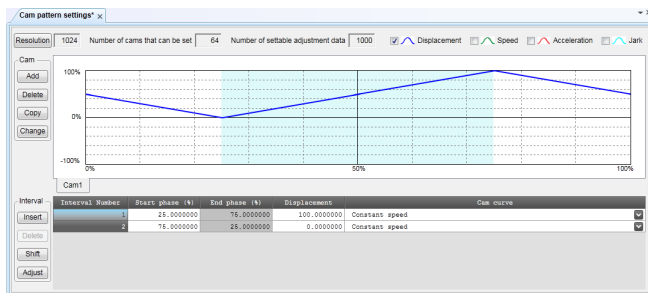

## 9.6.5 Advance Angle Correction Function

### ■ What is advance angle correction function?

"Advance angle correction function" is a function to correct the delay in the response of a machine system connected to an electronic cam output or the delay in a PLC arithmetic processing time. This function is used to advance the input phase to electronic cams for correcting the delay in the response of cam output axes.

The advance angle correction automatically increases a phase lead in proportion to the speed of the master axis; therefore, it is also suitable for correcting deviation in proportion to the speed. This function is available since FP7 MC Unit Ver. 1.20.

### ■ Specification of advance angle correction amount

Advance angle correction amounts are specified for each slave axis using a tool software or user program.

By setting "advance angle correction reference speed" and "advance angle correction reference amount", a correction amount is automatically calculated using an active "master axis input speed". The advance angle correction amount is calculated by the following formula.

$$\text{Advance angle correction amount} = \text{Master axis input speed information} \times \frac{\text{Advance angle correction reference amount [UM63F96-UM63F97]}}{\text{Advance angle correction reference speed [UM63F98-UM63F99]}}$$

\* Master axis input speed information: Speed information after clutch control

### ■ Internal processing of advance angle correction

The phase of the master axis which will be a reference of slave axis correction is obtained as operation data for according to the set values of advance angle amount. A correction amount for each slave axis is calculated based on this value as a reference.

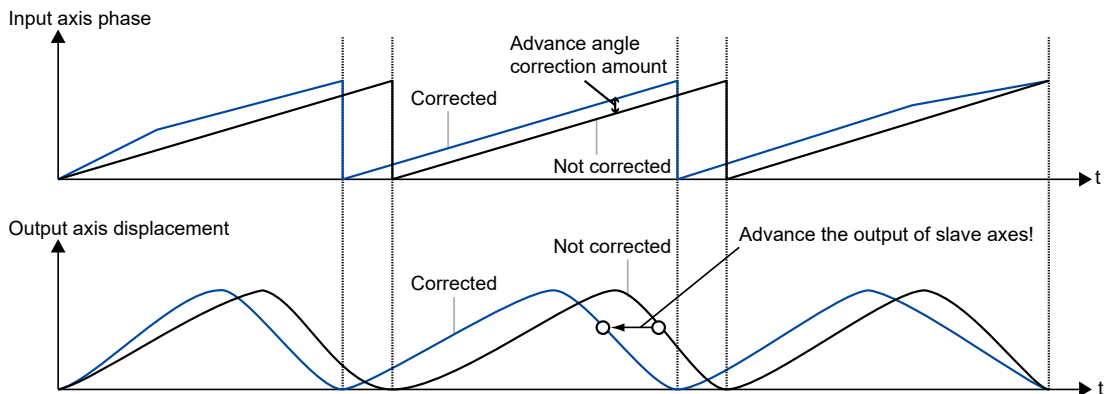

■ **Setting with tool software**

Set in the synchronous control setting dialog box.

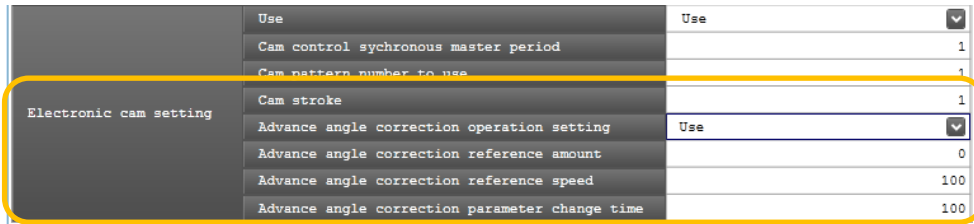

Parameter name	Overview
Advance angle correction operation setting	Select the use or non-use of the advance angle correction function.
Advance angle correction reference amount	When using the advance angle correction function, set the correction reference amount used by FP7 MC Unit for calculating the advance angle correction amount. The unit follows the unit system of the master axis. Setting range: -2147483648 to 2147483647 (The decimal point position is based on unit systems.)
Advance angle correction reference speed	When using the advance angle correction function, set the reference speed used by FP7 MC Unit for calculating the advance angle correction amount. The unit follows the unit system of the master axis. Setting range: 1 to 2147483647 (The decimal point position is based on unit systems.)
Advance angle correction parameter change time	Set the time required until a changed value is reflected when the parameter related to the advance angle correction is changed during the electronic cam operation. Setting range: 1 to 10000 ms

■ **Setting with user programs**

The following example shows the case that the advance angle correction reference amount of 1st axis is changed to 50 and the advance angle correction reference speed to 3000.

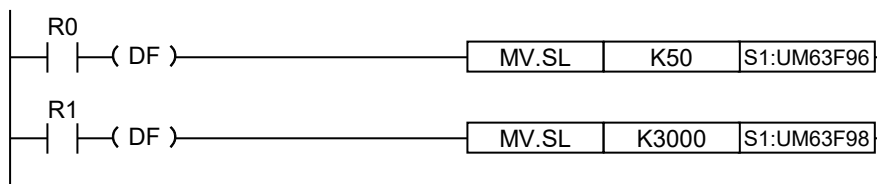

■ **Changing the advance angle correction amount during operation**

The advance angle correction amount can be changed during the operation.

In that case, the change processing starts by changing the set values of "advance angle correction reference speed" and "advance angle correction reference amount", and the speed change is complete in "advance angle correction parameter change time".

The synchronous control setting area of the unit memories used for the advance angle correction function is as follows.

The cam pattern reading results are as follows.

Axis no.	Unit memory no. (Hex)	Name	Default	Unit	Setting range and description						
Axis 1	UM 63F96 UM 63F97	Advance angle correction reference amount	K0	-	Set the correction reference amount for calculating the advance angle correction amount when using the advance angle correction function. Setting range: -2,147,483,648 to 2,147,483,647 The ranges vary depending on the unit settings as below. pulse: -2,147,483,648 to 2,147,483,647 pulse $\mu\text{m}$ (0.1 $\mu\text{m}$ ): -214,748,364.8 to 214,748,364.7 $\mu\text{m}$ $\mu\text{m}$ (1 $\mu\text{m}$ ): -2,147,483,648 to 2,147,483,647 $\mu\text{m}$ inch (0.00001 inch): -21,474.83648 to 21,474.83647 inches inch (0.0001 inch): -214,748.3648 to 214,748.3647 inches degree (0.1 degree): -214,748,364.8 to 214,748,364.7 degrees degree (1 degree): -2,147,483,648 to 2,147,483,647 degrees Any other settings will be errors. (Max. 31 bits)						
Axis 2	UM 64006 UM 64007										
:	:										
Axis 32	UM 64D26 UM 64D27										
:	:										
Axis 64	UM 65B26 UM 65B27										
Axis 1	UM 63F98 UM 63F99	Advance angle correction reference speed	U100	-	Set the reference speed for calculating the advance angle correction amount when using the advance angle correction function. <table border="1" style="width: 100%; border-collapse: collapse;"> <thead> <tr> <th>bit</th> <th>Name</th> <th>Description</th> </tr> </thead> <tbody> <tr> <td>31-0</td> <td>Advance angle correction reference speed</td> <td>                             Range: 1 to 2,147,483,647                              Any other settings will be errors.                              The ranges vary depending on the unit settings as below.                              Pulse: 1 to 2,147,483,647 pps  <math>\mu\text{m}</math>: 1 to 2,147,483,647 <math>\mu\text{m}/\text{s}</math>                              inch: 0.001 to 2,147,483.647 inch/s                              degree: 0.001 to 2,147,483.647 rev/s                         </td> </tr> </tbody> </table> * The unit follows the unit system of the master axis.	bit	Name	Description	31-0	Advance angle correction reference speed	Range: 1 to 2,147,483,647 Any other settings will be errors. The ranges vary depending on the unit settings as below. Pulse: 1 to 2,147,483,647 pps $\mu\text{m}$ : 1 to 2,147,483,647 $\mu\text{m}/\text{s}$ inch: 0.001 to 2,147,483.647 inch/s degree: 0.001 to 2,147,483.647 rev/s
bit	Name					Description					
31-0	Advance angle correction reference speed					Range: 1 to 2,147,483,647 Any other settings will be errors. The ranges vary depending on the unit settings as below. Pulse: 1 to 2,147,483,647 pps $\mu\text{m}$ : 1 to 2,147,483,647 $\mu\text{m}/\text{s}$ inch: 0.001 to 2,147,483.647 inch/s degree: 0.001 to 2,147,483.647 rev/s					
Axis 2	UM 64008 UM 64009										
:	:										
Axis 32	UM 64D28 UM 64D29										
:	:										
Axis 64	UM 65B28 UM 65B29										
Axis 1	UM 63F9A	Advance angle correction parameter change time	U100	ms	Set the time required until a changed value is reflected when the parameter related to advance angle correction (advance angle correction reference speed or advance angle correction reference amount) is changed during the electronic cam operation. <table border="1" style="width: 100%; border-collapse: collapse;"> <thead> <tr> <th>bit</th> <th>Name</th> <th>Description</th> </tr> </thead> <tbody> <tr> <td>15-0</td> <td>Advance angle correction parameter change time</td> <td>                             Range: 0 to 10,000 (ms)                              Any other settings will be errors.                         </td> </tr> </tbody> </table>	bit	Name	Description	15-0	Advance angle correction parameter change time	Range: 0 to 10,000 (ms) Any other settings will be errors.
bit	Name					Description					
15-0	Advance angle correction parameter change time					Range: 0 to 10,000 (ms) Any other settings will be errors.					
Axis 2	UM 6400A										
:	:										
Axis 32	UM 64D2A										
:	:										
Axis 64	UM 65B2A										

## Automatic Operation (Synchronous Control)

---

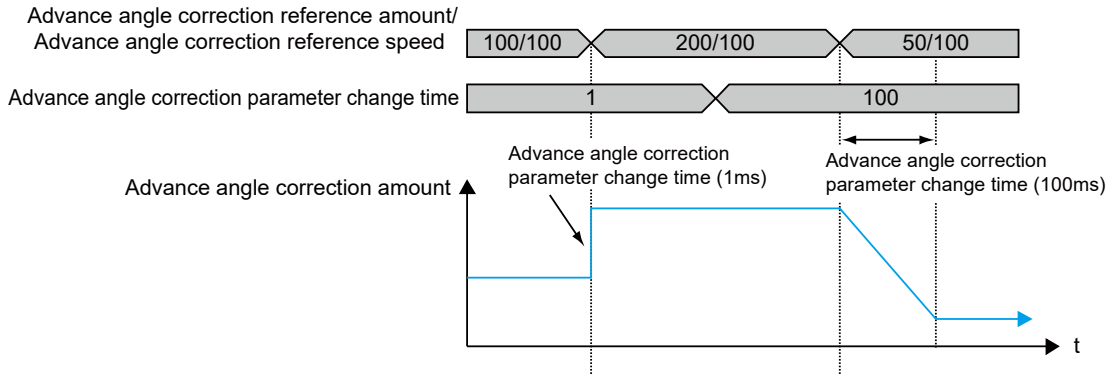

### NOTES

- "Advance angle correction reference speed" and "Advance angle correction reference amount" are signed 32-bit data. If they are changed by 16-bit (1-word) unit, they may be changed to unintended values. Always perform the rewriting by 32-bit (2-word) unit.
- When changing an "advance angle correction reference speed" or "advance angle correction reference amount" during operation, the timing that the unit acquires the changed "advance angle correction reference speed" or "advance angle correction reference amount" may deviate. Change either parameter of "advance angle correction reference speed" or "advance angle correction reference amount" to prevent the "advance angle correction amount" from being rapidly changed.



- When changing them during operation, the timing that the unit acquires the changed "advance angle correction reference speed" and "advance angle correction reference amount" may deviate.

It is possible to set whether to "use" or "not use" the advance angle correction function by the synchronous parameter "synchronous output function selection".

Parameter	Description
Use	<p>Input speed [speed after electronic clutch conversion] is calculated by the ratio of advance angle correction reference amount and advance angle correction reference speed and the following formula, and output.</p> $\text{Advance angle correction amount} = \text{Speed information after electronic clutch control} \times \frac{\text{Advance angle correction reference amount [UM63F96-UM63F97]}}{\text{Advance angle correction reference speed [UM63F98-UM63F99]}}$ <p>* Master axis input speed information: Speed information after clutch control</p>
Not use	<p>Input speed [speed after electronic clutch conversion] is considered to be equal to output speed [speed after advance angle correction conversion], and output. This is the state that the clutch is always connected (ON).</p>

The area for setting to use/not use the advance angle correction function is as follows.

Axis no.	Unit memory no. (Hex)	Name	Default	Setting range and description															
Axis 1	UM 63F41	Synchronous output function selection	H0	<p>Set the synchronous control function for each axis.</p> <table border="1"> <thead> <tr> <th>bit</th> <th>Name</th> <th>Description</th> </tr> </thead> <tbody> <tr> <td>0</td> <td>Electronic gear operation settings</td> <td rowspan="4">0: Not use 1: Use</td> </tr> <tr> <td>1</td> <td>Clutch operation setting</td> </tr> <tr> <td>2</td> <td>Electronic operation setting</td> </tr> <tr> <td>3</td> <td>Advance angle correction operation setting</td> </tr> <tr> <td>15-4</td> <td>—</td> <td>—</td> </tr> </tbody> </table>	bit	Name	Description	0	Electronic gear operation settings	0: Not use 1: Use	1	Clutch operation setting	2	Electronic operation setting	3	Advance angle correction operation setting	15-4	—	—
bit	Name				Description														
0	Electronic gear operation settings				0: Not use 1: Use														
1	Clutch operation setting																		
2	Electronic operation setting																		
3	Advance angle correction operation setting																		
15-4	—	—																	
Axis 2	UM 63FB1																		
:	:																		
Axis 32	UM 64CD1																		
:	:																		
Axis 64	UM 65AD1																		

■ Precautions for settings

- Overshoot or undershoot may occur according to settings when sufficient acceleration/deceleration time is not set for the start or stop of master axis while the advance angle correction function is used, or when an input speed is rapidly accelerated or decelerated by the direct connection or disconnection of a clutch while the master axis is operated.
- When using the advance angle correction function, set a sufficient acceleration/deceleration time on the master axis. When using the clutch function in combination, make the setting to prevent the occurrence of a rapid acceleration or deceleration using the slip function.

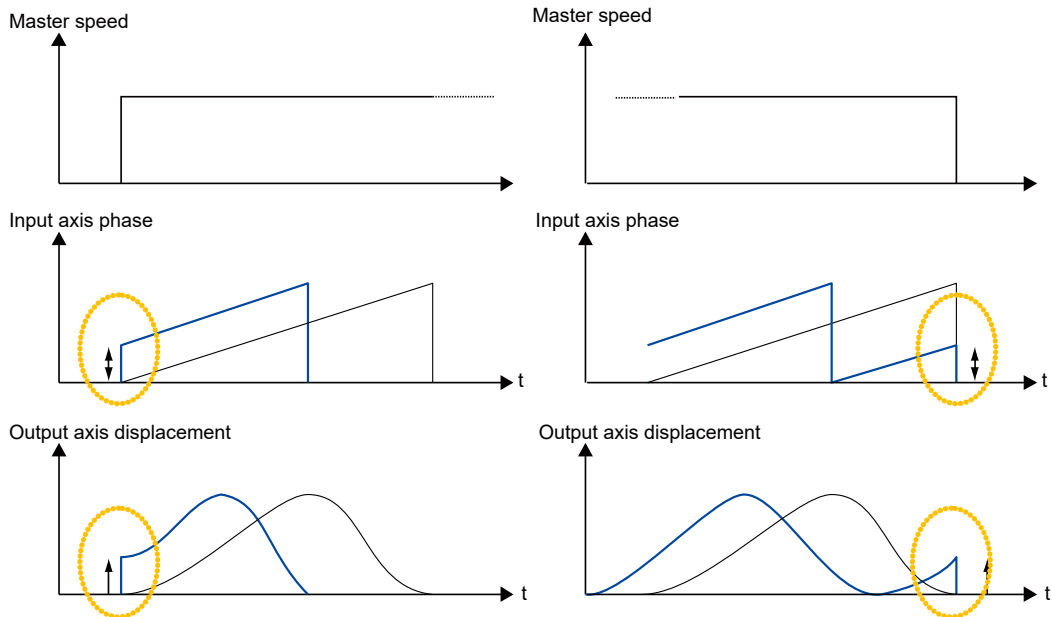

- Depending on the setting of “advance angle correction reference speed” or “advance angle correction reference amount”, a calculated advance angle correction amount may exceed the “cam control synchronous master axis cycle”. When the advance angle correction amount exceeds the “cam control synchronous master axis cycle”, the “synchronous cam master axis cycle” will be the upper limit as below. Set the parameter of advance angle correction which meets an input speed.

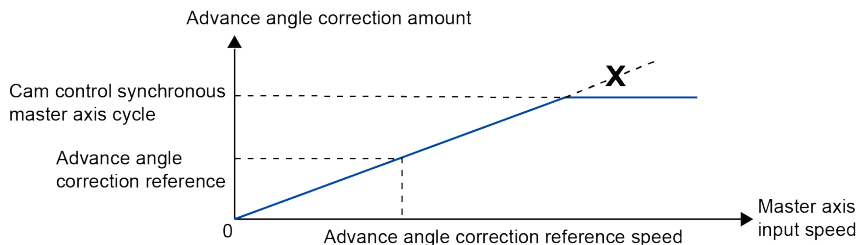

# 10

## Manual Operation (JOG Operation)

## 10.1 Settings and Operations of JOG Operation

In this example, a forward or reverse operation is performed in the JOG operation.

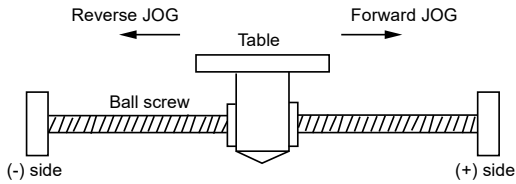

### ■ Settings

Item	Setting example
Acceleration/deceleration pattern	0: Linear acceleration/deceleration
Acceleration time (ms)	100 ms
Deceleration time (ms)	100 ms
Target speed	10000 pps

### ■ Operation diagram

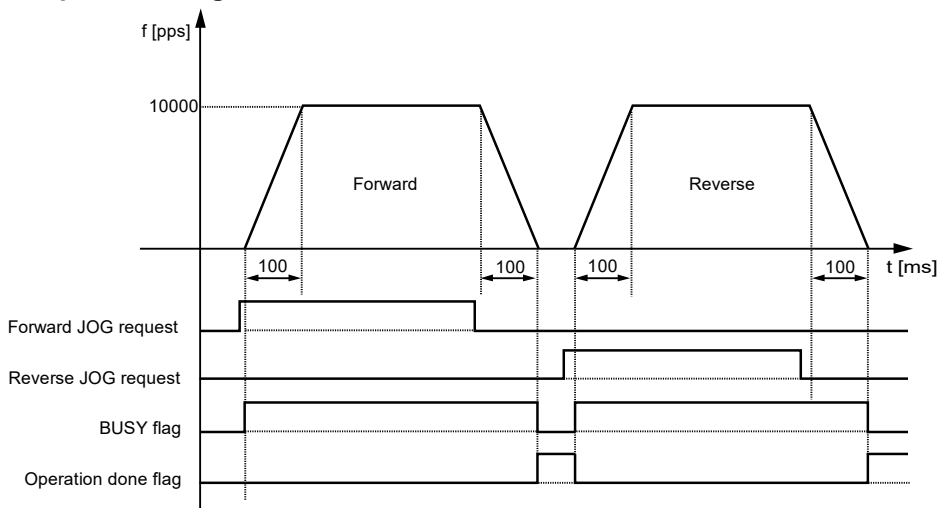

■ Operation of input control/output control signals

- When a JOG operation forward or reverse request (corresponding bit allocated to UM0019E to UM001A9) is on by a user program, the JOG operation control is performed.
- A busy flag (corresponding bit allocated to UM00090 to UM00095), which indicates that a requested operation is being controlled, will turn on when the JOG operation control starts, and it will turn off when the operation completes.
- An operation done flag (corresponding bit allocated to UM00096 to UM0009B), which indicates the completion of operation, will turn on when the current operation is completed, and it will be held until the next positioning control, JOG operation, or home return starts.

■ Allocation of unit memories

Signal name	Real axis				Virtual axis	
	Axes 1-16	Axes 17-32	Axes 33-48	Axes 49-64	Axes 1-16	Axes 17-32
JOG operation forward/reverse request (Note 1)	UM0019E (Axes 1-8)	UM001A0 (Axes 17-24)	UM001A2 (Axes 33-40)	UM001A4 (Axes 49-56)	UM001A6 (Axes 1-8)	UM001A8 (Axes 17-24)
	UM0019F (Axes 9-16)	UM001A1 (Axes 25-32)	UM001A3 (Axes 41-48)	UM001A5 (Axes 57-64)	UM001A7 (Axes 9-16)	UM001A9 (Axes 25-32)
BUSY flag (Note 2)	UM00090	UM00091	UM00092	UM00093	UM00094	UM00095
Operation done flag (Note 2)	UM00096	UM00097	UM00098	UM00099	UM0009A	UM0009B

(Note 1): Request flags for 8 axes are allocated to each unit memory (1 word). When the value of each bit is 1, it turns on. When the value of each bit is 0, it turns off.

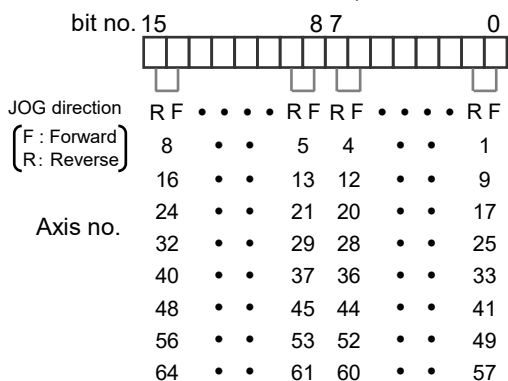

(Note 2): Flags or request signals for 16 axes are allocated to each unit memory (1 word). When the value of each bit is 1, it turns on. When the value of each bit is 0, it turns off.

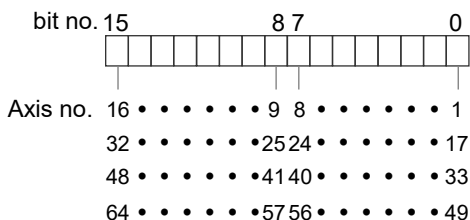

## 10.2 Changing Speed During JOG Operation

The target speed can be changed during the JOG operation.

### ■ Settings

Item	Setting example	
Acceleration/deceleration pattern	0: Linear acceleration/deceleration	
Acceleration time 1 (ms)	100 ms	
Deceleration time 1 (ms)	50 ms	
Target speed 1	10000 pps	
Acceleration time 2 (ms)	200 ms	As for the acceleration time, deceleration time and target speed after the speed change, write the setting values in the unit memories using a program.
Deceleration time 2 (ms)	150 ms	
Target speed 2	20000 pps	

### ■ Operation diagram

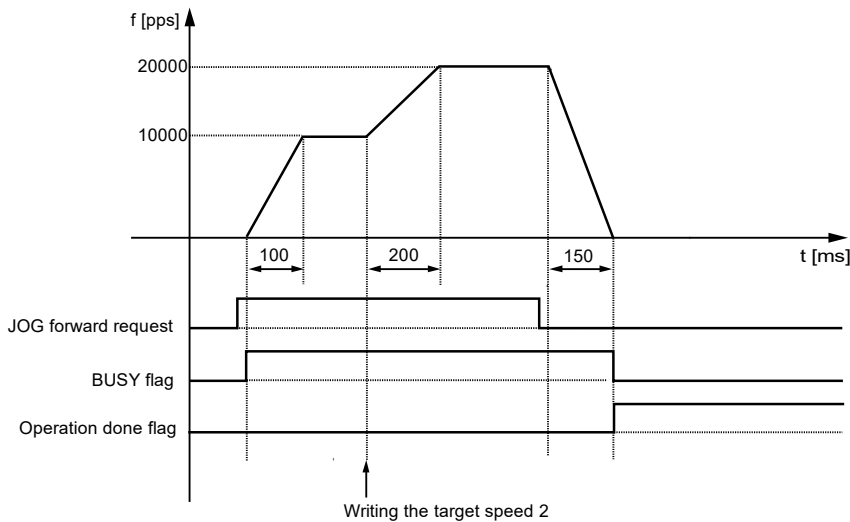

### ◆ KEY POINTS

- Only in the case of "JOG operation (Infinite rotation)", the speed during the JOG operation can be changed. It cannot be changed in the case of "JOG inching operation".
- The acceleration time and deceleration time when changing the target speed are the same as the values at the startup. (Ver.1.0)

■ Operation of input control/output control signals

- When a JOG operation forward or reverse request (corresponding bit allocated to UM0019E to UM001A9) is on by a user program, the JOG operation control is performed.
- The speed is changed by rewriting the following items in the parameter setting area of unit memories by a user program during the JOG operation;
  - JOG operation acceleration time (For axis 1: UM0326A)
  - JOG operation deceleration time (For axis 1: UM0326B)
  - JOG operation target speed (For axis 1: UM0326C to UM0326D).
- A busy flag (corresponding bit allocated to UM00090 to UM00095), which indicates that a requested operation is being controlled, will turn on when the JOG operation control starts, and it will turn off when the operation completes.
- An operation done flag (corresponding bit allocated to UM00096 to UM0009B), which indicates the completion of operation, will turn on when the current operation is completed, and it will be held until the next positioning control, JOG operation, or home return starts.

■ Allocation of unit memories

Signal name	Real axis				Virtual axis	
	Axes 1-16	Axes 17-32	Axes 33-48	Axes 49-64	Axes 1-16	Axes 17-32
JOG operation forward/reverse request (Note 1)	UM0019E (Axes 1-8)	UM001A0 (Axes 17-24)	UM001A2 (Axes 33-40)	UM001A4 (Axes 49-56)	UM001A6 (Axes 1-8)	UM001A8 (Axes 17-24)
	UM0019F (Axes 9-16)	UM001A1 (Axes 25-32)	UM001A3 (Axes 41-48)	UM001A5 (Axes 57-64)	UM001A7 (Axes 9-16)	UM001A9 (Axes 25-32)
BUSY flag (Note 2)	UM00090	UM00091	UM00092	UM00093	UM00094	UM00095
Operation done flag (Note 2)	UM00096	UM00097	UM00098	UM00099	UM0009A	UM0009B

(Note 1): Request flags for 8 axes are allocated to each unit memory (1 word). When the value of each bit is 1, it turns on. When the value of each bit is 0, it turns off.

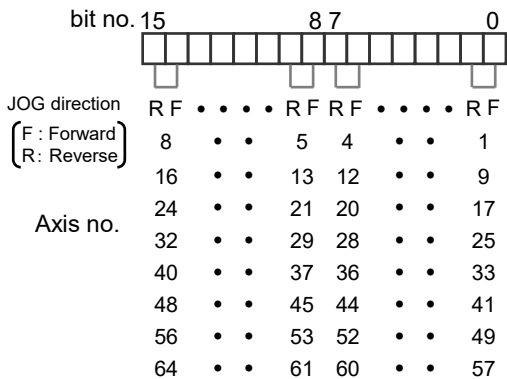

## Manual Operation (JOG Operation)

---

(Note 2): Flags or request signals for 16 axes are allocated to each unit memory (1 word). When the value of each bit is 1, it turns on. When the value of each bit is 0, it turns off.

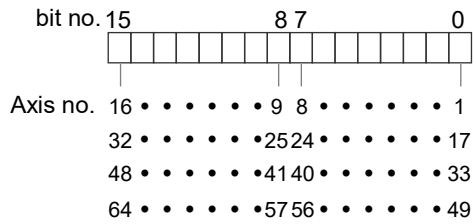



MEMO

## 10.3 Setting and Operation of JOG Inching Operation

In this example, a forward or reverse operation is performed in the JOG operation by the inching operation.

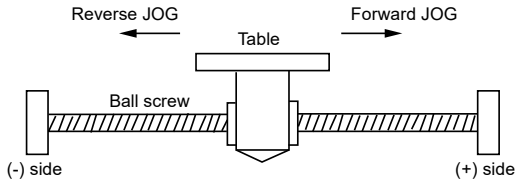

### ■ Settings

Item	Setting example
Acceleration/deceleration pattern	0: Linear acceleration/deceleration
Acceleration time (ms)	100 ms
Deceleration time (ms)	100 ms
Target speed	10000 pps
JOG inching movement amount	10000 pulses

### ■ Operation diagram

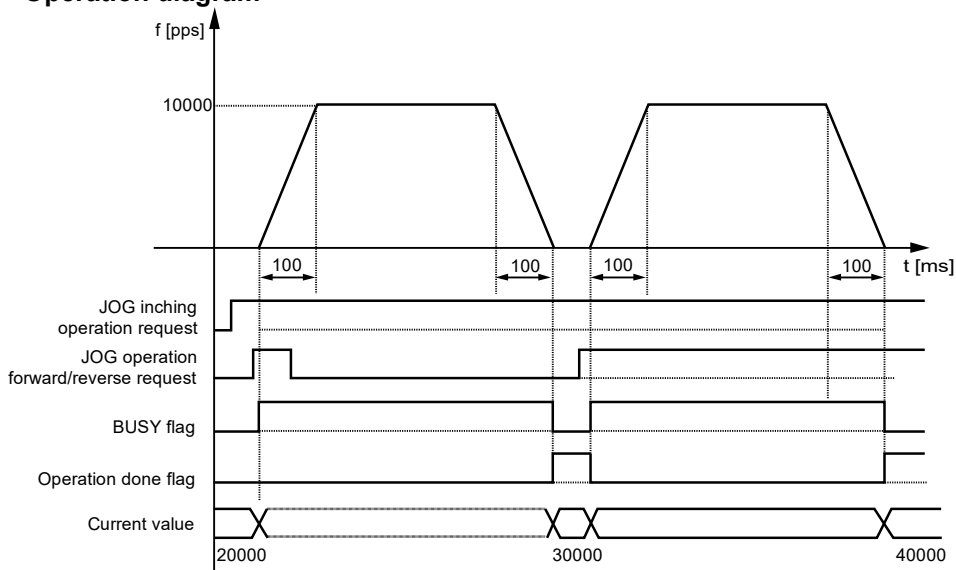

### ◆ KEY POINTS

- The inching operation starts at the leading edge of the JOG forward/reverse request. Also, when the request signal is short, it operates until the pulse set for "inching movement" is output.

■ Operation of input control/output control signals

- When a JOG inching request (corresponding bit allocated to UM001AA to UM001AF) is on by a user program and a JOG operation forward or reverse request (corresponding bit allocated to UM0019E to UM001A9) turns on, the JOG inching operation will be performed. The JOG inching operation starts when the edge of the JOG operation forward or reverse request changes to on from off.
- A busy flag (corresponding bit allocated to UM00090 to UM00095), which indicates that a requested operation is being controlled, will turn on when the JOG inching operation control starts, and it will turn off when the operation completes.
- An operation done flag (corresponding bit allocated to UM00096 to UM0009B), which indicates the completion of operation, will turn on when the current operation is completed, and it will be held until the next positioning control, JOG operation, or home return starts.

■ Allocation of unit memories

Signal name	Real axis				Virtual axis	
	Axes 1-16	Axes 17-32	Axes 33-48	Axes 49-64	Axes 1-16	Axes 17-32
JOG inching operation request (Note 1)	UM001AA	UM001AB	UM001AC	UM001AD	UM001AE	UM001AF
JOG operation forward/reverse request (Note 2)	UM0019E (Axes 1-8)	UM001A0 (Axes 17-24)	UM001A2 (Axes 33-40)	UM001A4 (Axes 49-56)	UM001A6 (Axes 1-8)	UM001A8 (Axes 17-24)
	UM0019F (Axes 9-16)	UM001A1 (Axes 25-32)	UM001A3 (Axes 41-48)	UM001A5 (Axes 57-64)	UM001A7 (Axes 9-16)	UM001A9 (Axes 25-32)
BUSY flag (Note 1)	UM00090	UM00091	UM00092	UM00093	UM00094	UM00095
Operation done flag (Note 1)	UM00096	UM00097	UM00098	UM00099	UM0009A	UM0009B

(Note 1): Flags or request signals for 16 axes are allocated to each unit memory (1 word). When the value of each bit is 1, it turns on. When the value of each bit is 0, it turns off.

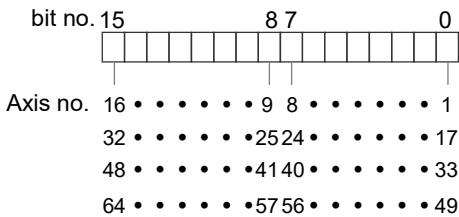

(Note 2): Request flags for 8 axes are allocated to each unit memory (1 word). When the value of each bit is 1, it turns on. When the value of each bit is 0, it turns off.

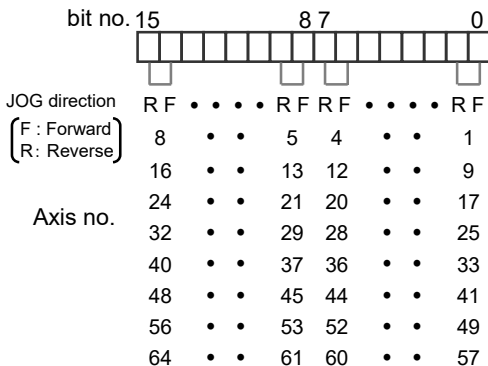

## 10.4 Sample Programs

### 10.4.1 Sample Program (JOG Operation)

The operation for starting the JOG operation is mainly divided into five steps on a user program.

- Read flags stored in the unit memories (input control area).
- Control the Servo ON/OFF.
- Check the state if the control of each axis can be started.
- Set the condition for the JOG operation (option), confirm the required start condition and start the JOG operation.
- Write operation results in the unit memories (output control area).

(Note): The sample program on the next page is for activating the JOG operation of the axis number 1 for FP7 MC Unit installed in the slot number 1. To simplify the explanation, the part related to the JOG operation is extracted.

#### ■ Contents of sample program

Mark	Description
①	Read flags indicating states from the input control area of the unit memories (UM) to arbitrary areas (WR). Read flags such as connection confirmation flag, servo lock flag, busy flag, and error flag.
②	Servo ON/OFF control program
③	Check required conditions and replace it with the start enabled flag (R110) in the program.
④	JOG operation program
	a) Set the following operations as necessary. Changing the speed during the JOG operation, setting and switching the JOG inching operation.
	b) Start the JOG operation (forward), start JOG operation (reverse).
⑤	Write flags to the output control area of the unit memories (UM) from arbitrary area (WR) where the start conditions are written. JOG operation start, JOG inching operation.



#### ◆ KEY POINTS

- In the case of "JOG operation (Infinite rotation)", the unit operates by the level signals of "JOG forward/reverse request".
- The "JOG inching operation" starts at the leading edge of the "JOG forward/reverse request".
- It is possible to switch between "JOG operation (Infinite rotation)" and "JOG inching operation" by turning ON/OFF the corresponding bit to the "JOG inching operation request" area in the unit memories.

■ Sample program

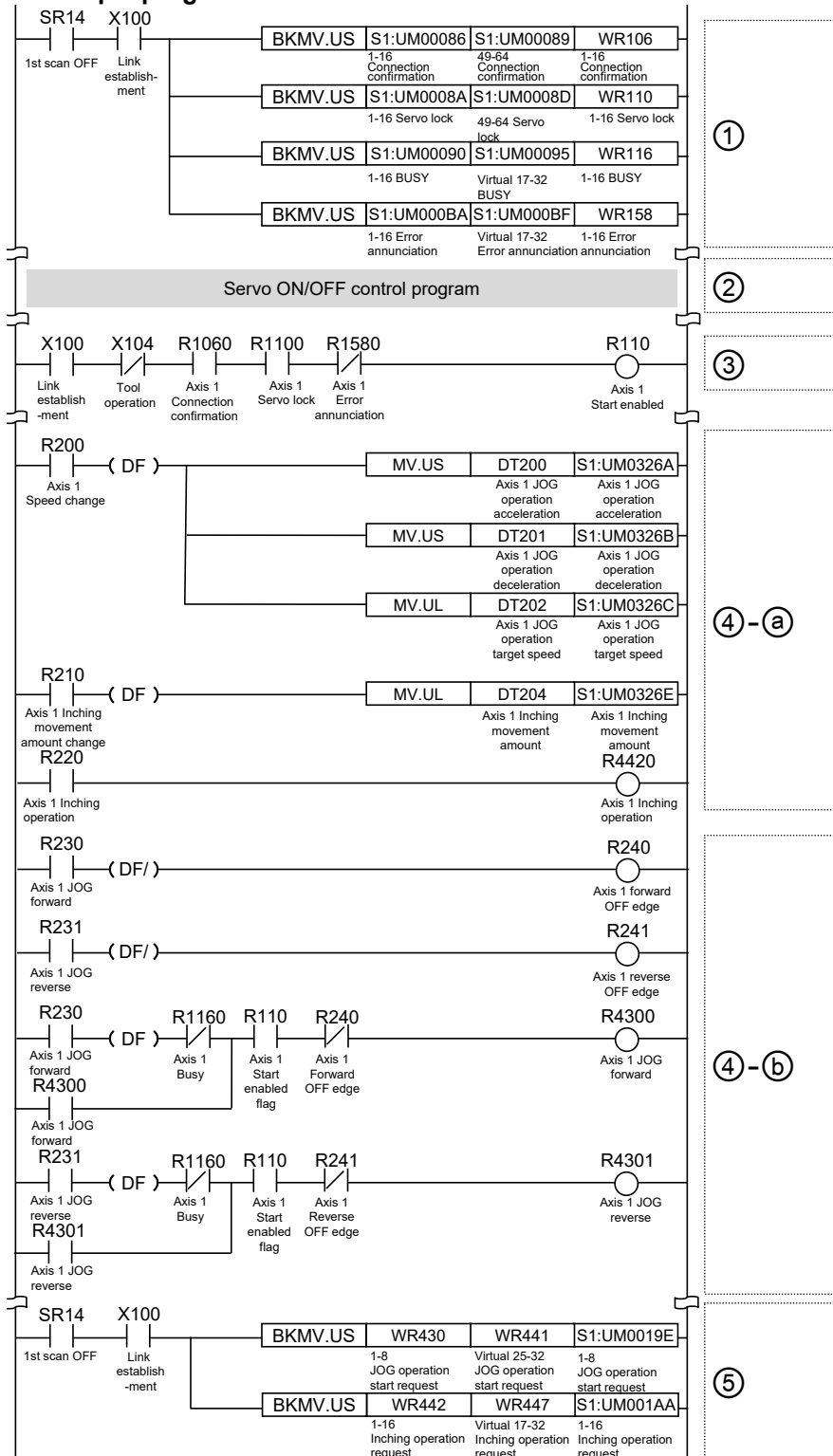

## 10.4.2 Precautions on Programming

### ■ Precautions on programming

- If any value such as an inching movement, acceleration time, deceleration time or target speed is out of the specified range, a setting value error will occur at the time of startup.
- Unit memory numbers allocated to flags and start requests vary depending on axis numbers.
- A specified slot number varies depending on the installation position of the unit.

### ■ Operation at Over limit input (Limit is valid)

Condition	Direction	Limit status	Operation
When JOG operation is started	Forward	Over limit input (+): ON	Not executable, Error occurs.
		Over limit input (-): ON	Executable
	Reverse	Over limit input (+): ON	Executable
		Over limit input (-): ON	Not executable, Error occurs.
During JOG operation	Forward	Over limit input (+): ON	Deceleration stop, Limit error occurs.
	Reverse	Over limit input (-): ON	Deceleration stop, Limit error occurs.

### ■ Operation when an error occurs

The operation of FP7 MC Unit when an error occurs varies according to the "MC common settings" of FP7 MC Unit and the "CPU Configuration" of the CPU unit. Note that the JOG operation may be restarted depending on the settings and execution conditions.

Example) When the execution condition for JOG is on, the operation is restarted:

Condition	Unit	Setting method	Parameter name	Setting example	
①	FP7 MC Unit	CMI: MC common settings	Operation when an error occurs	All axes stop	
②	①	FP7 MC Unit	CMI: MC common settings	Error alarm to CPU unit	No
②	①	FP7 MC Unit	CMI: MC common settings	Error alarm to CPU unit	Yes
	②	CPU unit	FPWIN GR7: FP7 Configuration > CPU Configuration	Operation when unit error occurs	Operation continues.

When the setting is like the condition (1), when an error occurs during the JOG operation, normal axes stop once. However, when the setting is like the condition (2) (a) or (2) (b), if the JOG operation request is on, the JOG operation will start again after the stop. If such an event needs to be avoided, add error annunciation flags of other axes as interlock release signals.

# 11

## Manual Operation (Home Return)

## 11.1 Types of Home Return

The home return is a function to move a position to the origin of a reference position and set the coordinate to zero. The following ten home return methods are available for FP7 MC Unit.

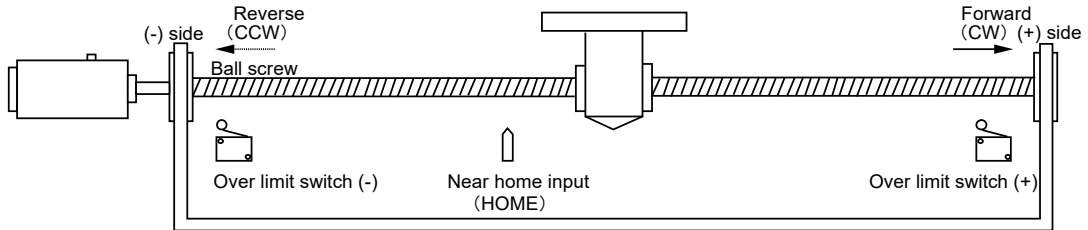

Type of return	Reference position origin	Operation overview
DOG method 1	Home (Z phase), based on front end	The leading edge of the first home position (Z phase) is set as a home position after the detection of the leading edge of a near home input (HOME).
DOG method 2	Near home input (HOME), based on front end	The leading edge of a near home input (HOME) is detected and it is set as a home position.
DOG method 3	Home (Z phase), based on back end	The leading edge of the first home position (Z phase) in the home return direction set as a home position after the detection of a trailing edge (back end) of the near home input (HOME).
DOG method 4	Near home input (HOME), based on back end	The trailing edge (back end) of a near home input (HOME) is detected and it is set as a home position.
Limit method 1	Home (Z phase), based on front end	Reverses after detecting the leading edge of the limit switch on the opposite side of the home return direction. After that, the operation stops at the first leading edge of the home position (Z phase). It is set as a home position.
Limit method 2	Edge detection of limit switch	Detects the leading edge of the limit switch in the home return direction and stops. It is set as a home position.
Phase Z method	Edge detection of home (Z phase)	Moves the current position to the home return direction, and stops at the position where the leading edge of the first home position (Z phase) is detected. It is set as a home position.
Stop-on-contact method 1	Based on stop-on-contact	Stops by a mechanical stopping mechanism as a stopper. A position when a constant time elapses at a torque value larger than a specified value is set as a home position.
Stop-on-contact method 2	Stop-on-contact + Z phase, based on front	Although the operation is similar to the stop-on-contact method, the first position where the Z phase is detected is set as a home position by performing the reverse operation after the stop by a stopper.
Data set method	-	The current value is set as a home position.



■ **DOG method 1 (Based on front end + Z phase)**

- The leading edge of the first home position (Z phase) is set as a home position after the detection of the leading edge of a near home input (HOME).
- In the case of the DOG method 1, the operation stops once after the detection of the leading edge of a near home input (HOME) as the home return positioning control mode (Method33/34) of Servo Amplifier A6B/A5B is used. The home position is searched at a home return creep speed again, and the operation stops when the leading edge of the first home position (Z phase) is detected.

(Note): The home return positioning control mode (Method33/34) of Servo Amplifier A6B/A5B is a mode to detect an index pulse as a home position. The home return direction of Method33 is the - direction, and that of Method 34 is the + direction.

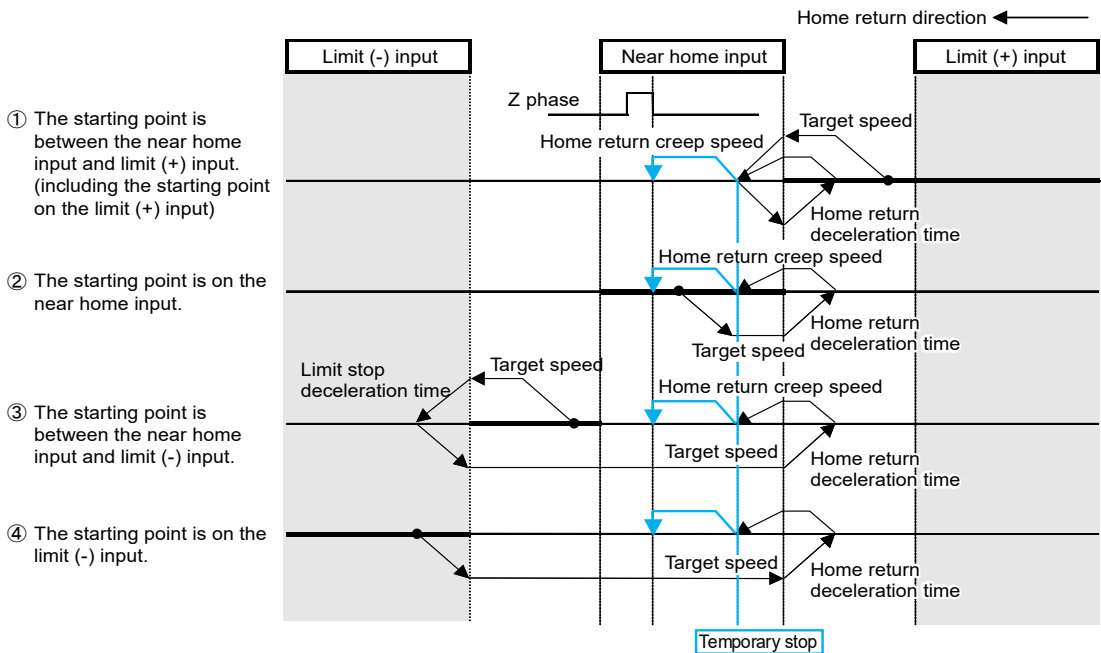

■ **DOG method 2 (Based on front end)**

- The leading edge of a near home input (HOME) is detected and it is set as a home position.
- After the leading edge of a near home input (HOME) is detected, the deceleration stop is performed in the home return deceleration time. After reversing, the near home input (HOME) is searched at a home return creep speed, and the operation stops at a detected position.

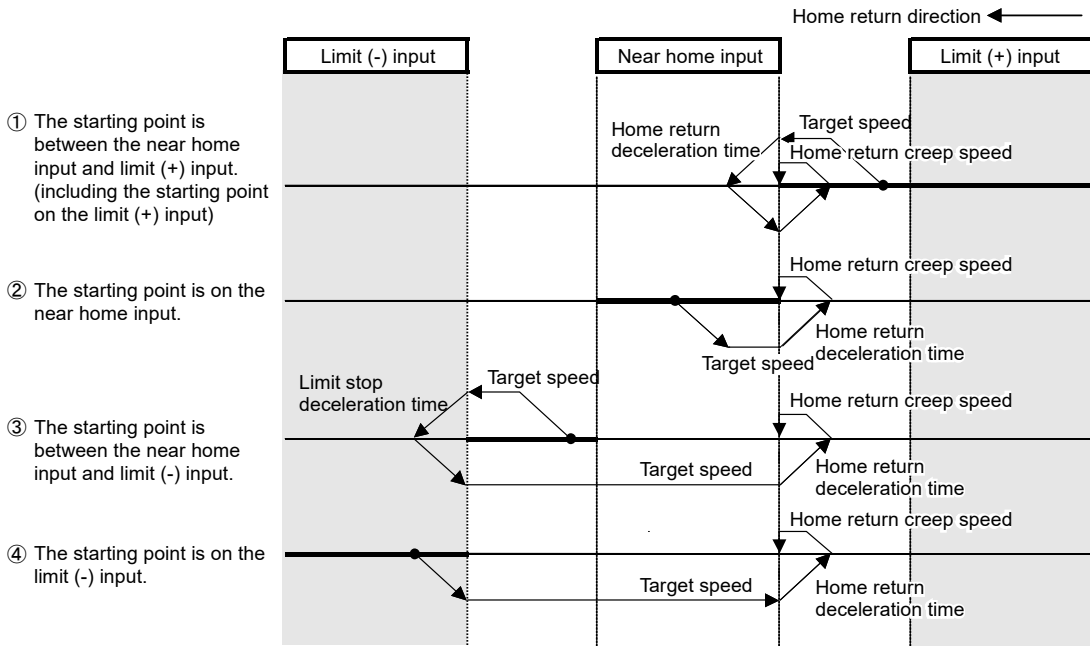

■ **DOG method 3 (Based on back end + Z phase)**

- The leading edge of the first home position (Z phase) in the home return direction set as a home position after the detection of a trailing edge (back end) of the near home input (HOME).
- In the case of the DOG method 3, the operation stops once after the detection of the trailing edge of a near home input (HOME) as the home return positioning control mode (Method33/34) of Servo Amplifier A6B/A5B is used. The home position is searched at a home return creep speed again, and the operation stops when the leading edge of the first home position (Z phase) is detected.

(Note): The home return positioning control mode (Method33/34) of Servo Amplifier A6B/A5B is a mode to detect an index pulse as a home position. The home return direction of Method33 is the - direction, and that of Method34 is the + direction.

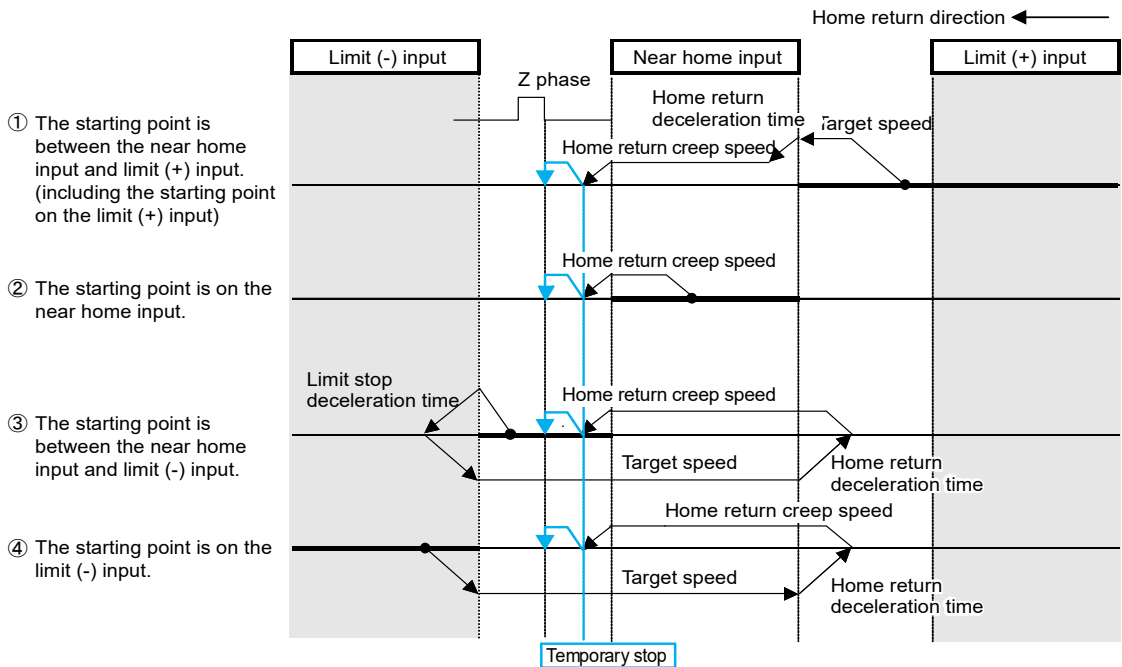

## Manual Operation (Home Return)

### ■ DOG method 4 (Based on back end)

- The trailing edge of a near home input (HOME) is detected and it is set as a home position.
- After the trailing edge of a near home input (HOME) is detected, the deceleration stop is performed in the home return deceleration time. After reversing, the near home input (HOME) is searched at a home return creep speed, and the operation stops at a detected position.

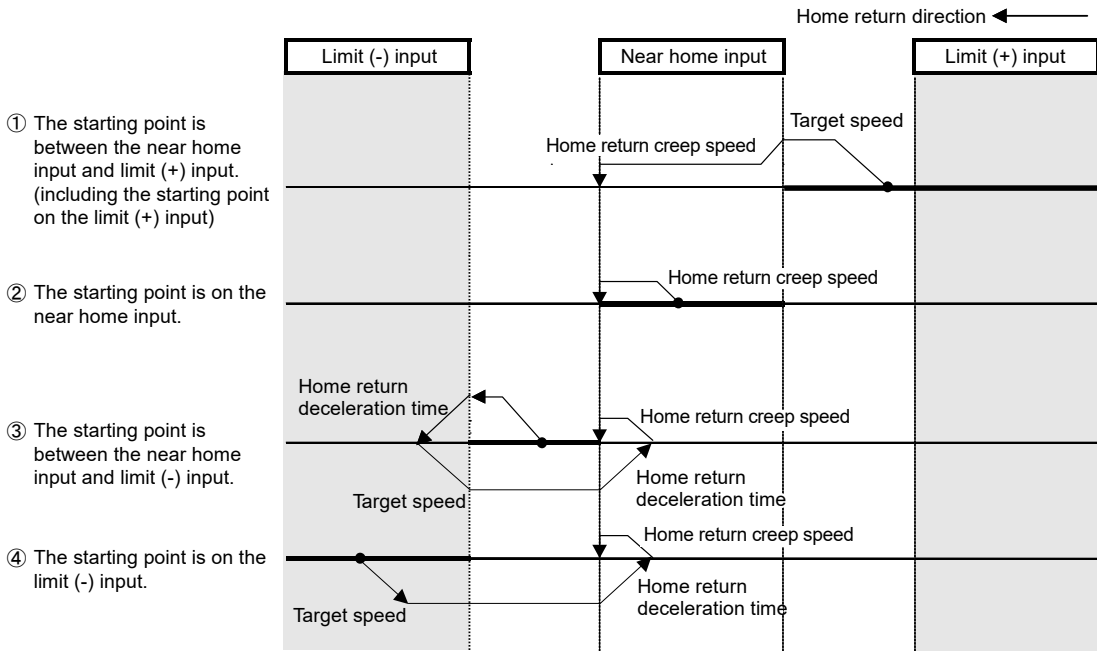

This figure shows the case that the movement toward the home return direction is started.

■ **Limit method 1 (Limit signal + Z phase)**

- Reverses after detecting the leading edge of the limit switch on the opposite side of the home return direction. After that, the operation stops at the first leading edge of the home position (Z phase). It is set as a home position.
- In the case of the limit method 1, the operation stops once in the home return deceleration time after the detection of the trailing edge of the limit input as the home return positioning control mode (Method33/34) of Servo Amplifier A6B/A5B is used. The home position is searched at a home return creep speed again, and the operation stops when the leading edge of the first home position (Z phase) is detected.

(Note): The home return positioning control mode (Method33/34) of Servo Amplifier A6B/A5B is a mode to detect an index pulse as a home position. The home return direction of Method33 is the - direction, and that of Method34 is the + direction.

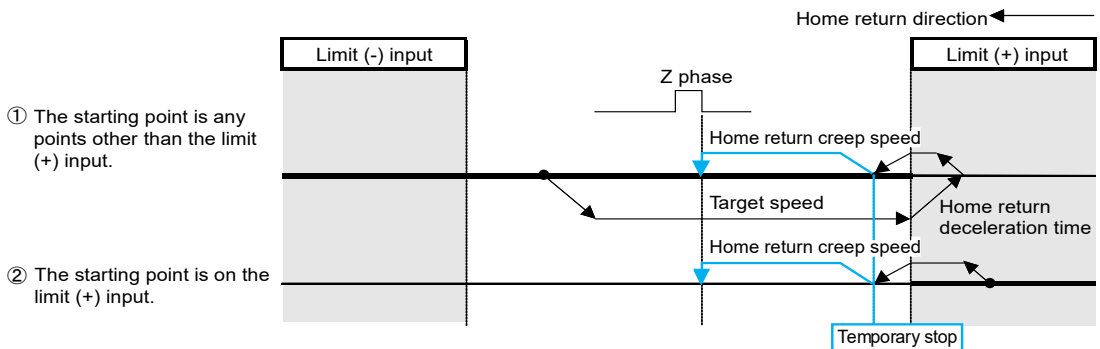

■ **Limit method 2 (Limit signal)**

Detects the leading edge of the limit switch in the home return direction and stops. It is set as a home position.

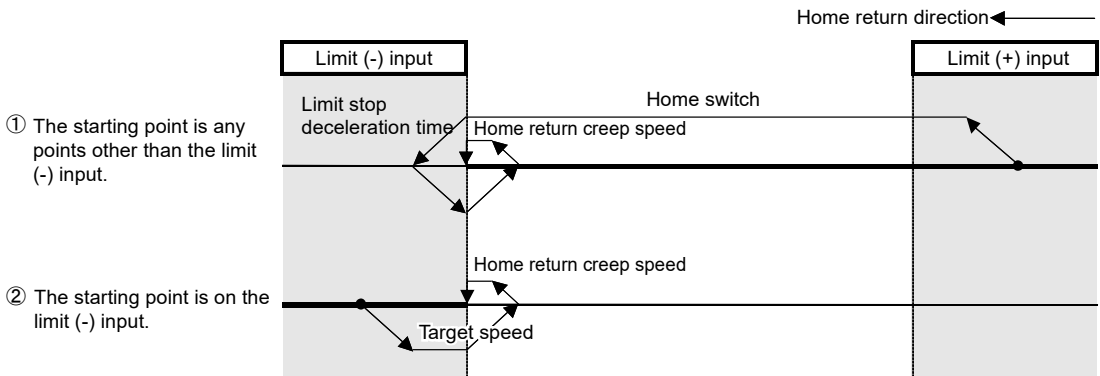

## Manual Operation (Home Return)

### ■ Phase Z method

The home position is searched at a home return creep speed from the current position to the home return direction, and the operation stops at the leading edge of the first home position (Z phase). For the Z phase method, the home return positioning control mode (Method33/34) of Servo Amplifier A6B/A5B is used.

(Note): The home return positioning control mode (Method33/34) of Servo Amplifier A6B/A5B is a mode to detect an index pulse as a home position. The home return direction of Method33 is the - direction, and that of Method34 is the + direction.

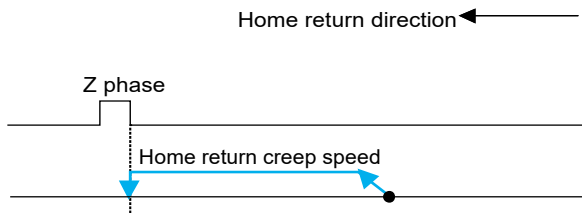

### ■ Stop-on-contact method 1

Stops by a mechanical stopping mechanism such as a stopper. A position when the stop-on-contact time (ms) elapses at a torque value larger than "Stop-on-contact torque value (%)" set in the axis parameter of CMI is regarded as a home position.

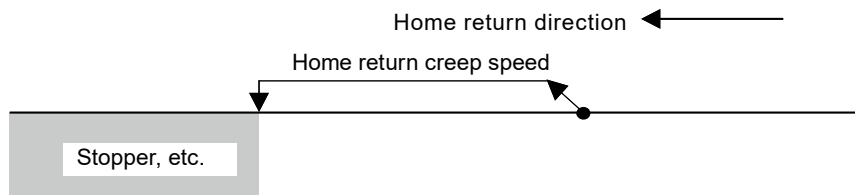

### ■ Stop-on-contact method 2 (Stop-on-contact + Z phase)

Performs the reverse operation after the stop by a stopper and stops at the position where the first home position (Z phase) is detected although the operation is similar to the stop-on-contact method. This position is set as a home position.

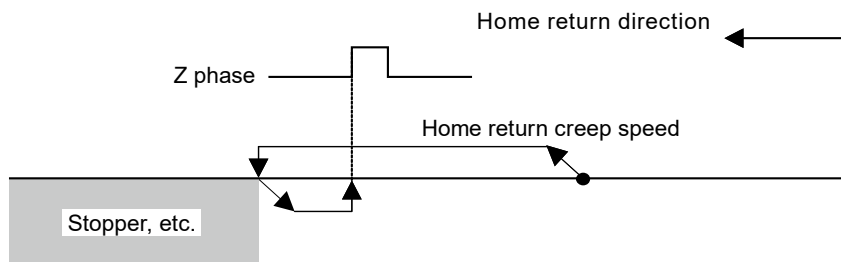

### ■ Data set method

The current value is set as a home position.

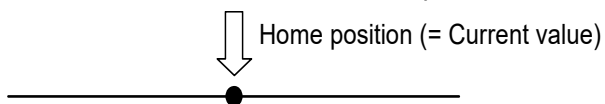



**◆ REFERENCE**

---

---

- For details of the connections of over limit switches and near home switches, refer to "4.5 Connection of Limit and Near Home Switches".

## 11.2 Operation of Home Return

In this example, the leading edge of the first home position (Z phase) is set as a home position after the detection of the leading edge of a near home input (HOME). Select "DOG method 1".

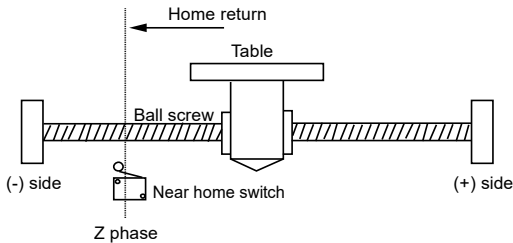

### ■ Settings

Item	Setting example
Return setting code	0: DOG method 1
Return direction	0: Limit (-) direction
Acceleration time (ms)	100 ms
Deceleration time (ms)	100 ms
Target speed	10000 pps
Return creep speed	1000 pps

### ■ Operation diagram

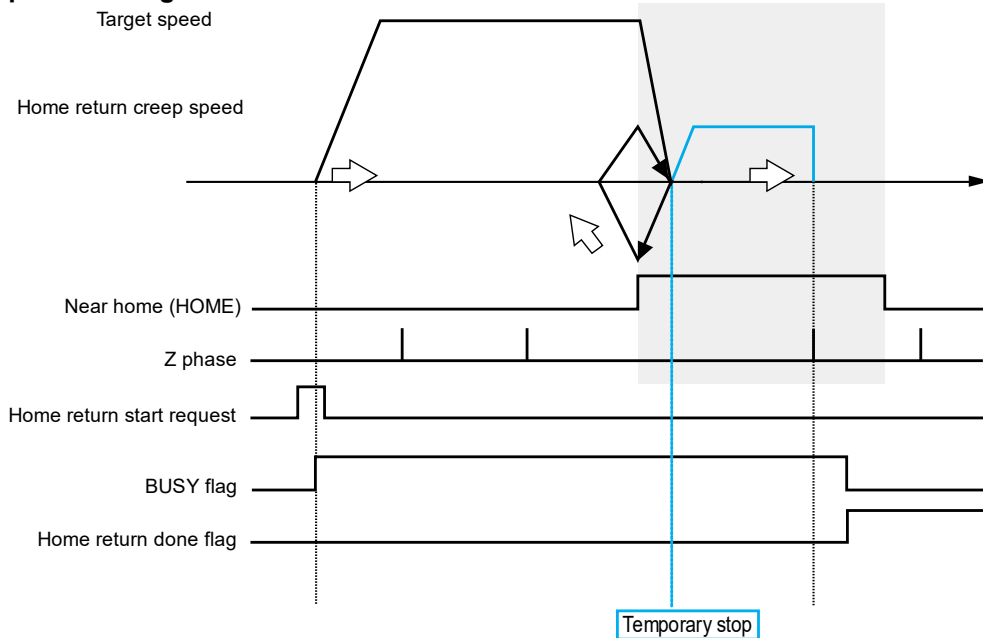



### ■ Operation of input control/output control signals

- When the home return request (corresponding bit allocated to UM00198 to UM0019D) turns on by a user program, the home return will start. The home return request will be enabled at the edge where the contact turns on.
- The BUSY flag (corresponding bit allocated to UM00090 to UM00095), which indicates that a requested operation is being controlled, will turn on when the control starts, and it will turn off when the operation completes.
- The home return done flag (corresponding bit allocated to UM0009C to UM000A1), which indicates the completion of operation, will turn on when the current operation is completed, and it will be held until the next positioning control, JOG operation, or home return starts.

### ■ Allocation of unit memories

Signal name	Real axis				Virtual axis	
	Axes 1-16	Axes 17-32	Axes 33-48	Axes 49-64	Axes 1-16	Axes 17-32
Home return start request	UM00198	UM00199	UM0019A	UM0019B	UM0019C	UM0019D
BUSY flag	UM00090	UM00091	UM00092	UM00093	UM00094	UM00095
Home return done flag	UM0009C	UM0009D	UM0009E	UM0009F	UM000A0	UM000A1

(Note 1): Flags or request signals for 16 axes are allocated to each unit memory (1 word) in the above table. When the value of each bit is 1, it turns on. When the value of each bit is 0, it turns off.

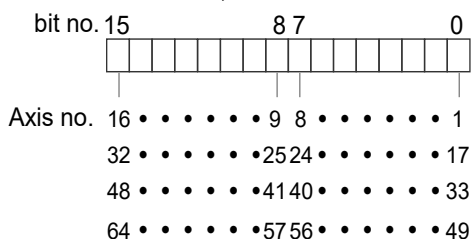

### ◆ KEY POINTS

- In the case of the DOG method 1, the operation stops once after the detection of the leading edge of a near home input (HOME) as the home return positioning control mode (Method33/34) of Servo Amplifier A6B/A5B is used. The home position is searched at a home return creep speed again, and the operation stops when the leading edge of the first home position (Z phase) is detected.

## 11.3 Sample Programs

---

### 11.3.1 Sample Program (Home Return)

---

The operation for starting the home return operation is mainly divided into five steps on a user program.

- Read flags stored in the unit memories (input control area).
- Control the Servo ON/OFF.
- Check the condition if the control of each axis can be started.
- Confirm the condition and start the home return.
- Write operation results in the unit memories (output control area).

(Note): The sample program on the next page is for activating the home return of the axis number 1 for the FP7 MC Unit installed in the slot number 1. To simplify the explanation, the part related to the home return operation is extracted.

#### ■ Contents of sample program

Mark	Description
①	Read flags indicating states from the input control area of the unit memories (UM) to arbitrary areas (WR). Read flags such as connection confirmation flag, servo lock flag, busy flag, and error flag.
②	Servo ON/OFF control program
③	Check required conditions and replace it with the start enabled flag (R110) in the program.
④	Home return start program.
⑤	Write flags to the output control area of the unit memories (UM) from arbitrary area (WR) where the start conditions are written. Home return start



#### ◆ KEY POINTS

---

- **Parameters related to the home return operation are set in the axis parameter of CMI. Refer to “5.2.4 Axis Parameters (Operation)”.**

■ Sample program

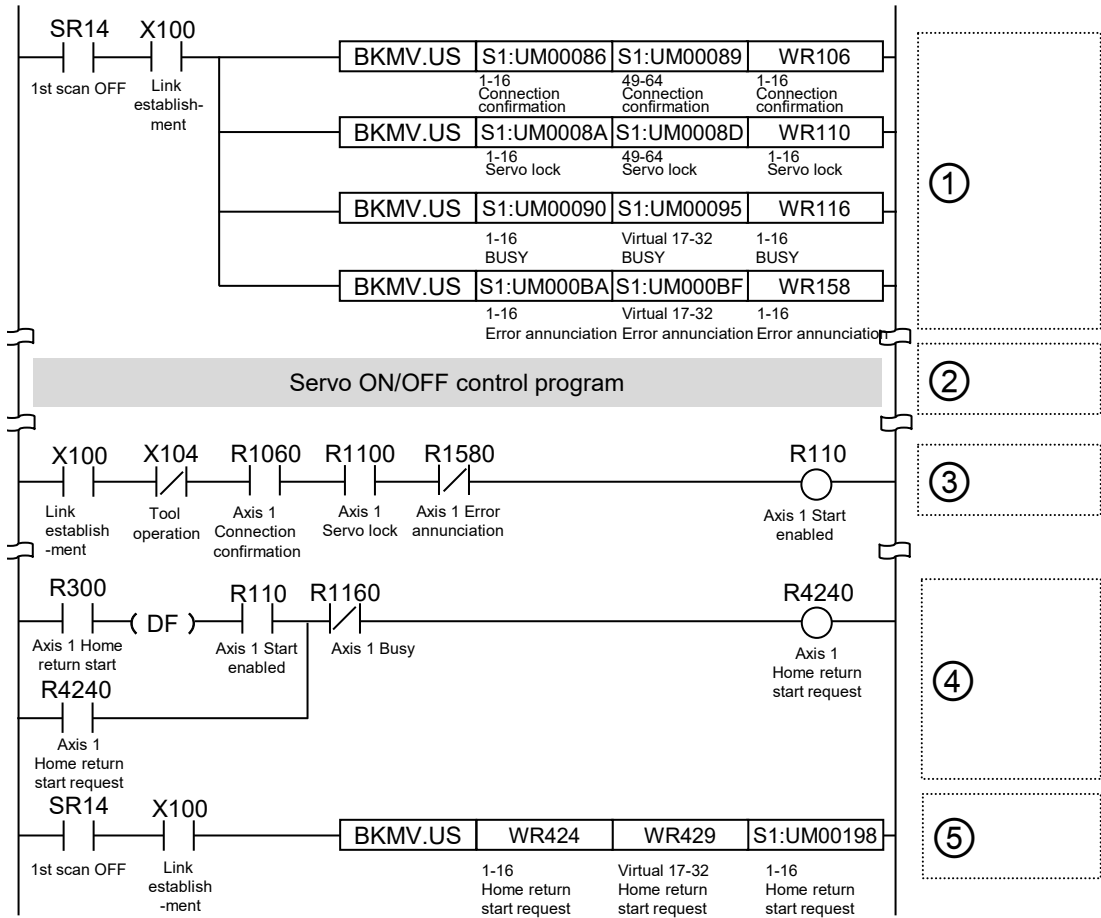

### 11.3.2 Precautions on Programming

---

#### ■ Precautions on programming

- If any value such as a home return setting code, acceleration time, deceleration time, target speed or creep speed is out of the specified range, a setting value error occurs at the time of startup.
- For the home return methods which are based on the home position (Z phase) (i.e. DOG method 1, DOG method 3, Limit method 1, Z phase method and Stop-on-contact method 2), the operation after shifting to the creep speed is controlled by servo amplifier. Therefore, the stop request made by FP7 MC Unit is invalid.
- Unit memory numbers allocated to flags and start requests vary depending on axis numbers.
- The specified slot number varies depending on the installation position of the unit.

#### ■ Operation at Over limit input (Limit is valid)

Condition	Direction	Limit status	Operation
When Home return operation is executed	Forward	Over limit input (+): ON	Executable
		Over limit input (-): ON	Executable
	Reverse	Over limit input (+): ON	Executable
		Over limit input (-): ON	Executable
During Home return operation	Forward	Over limit input (+): ON	Automatic reverse operation
	Reverse	Over limit input (-): ON	Automatic reverse operation

# 12

## Stop Functions

## 12.1 Type of Stop Functions

### 12.1.1 Type of Stop Functions

- The following seven stop operations are available.
- The system stop, emergency stop, deceleration stop, and pause will be effective when allocated request signals turn on by user programs.
- The limit stop, software limit stop, and error stop will be effective when corresponding conditions are established.

#### ■ Type of stop operations

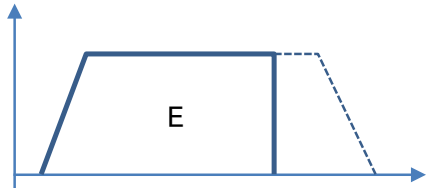
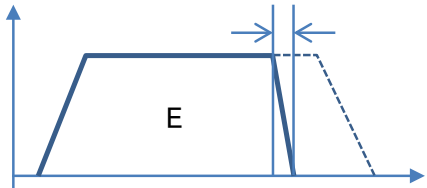
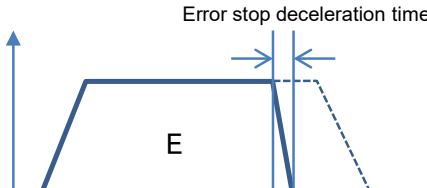
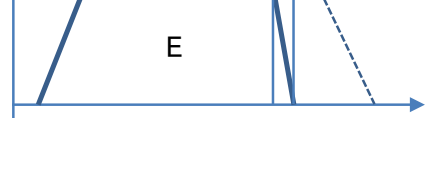
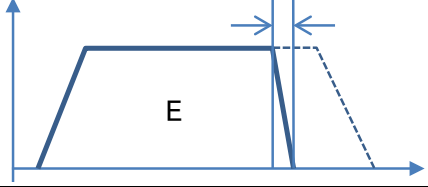
Name	Time chart	Occurrence condition and operation
System stop		<ul style="list-style-type: none"> <li>• Once a system stop request (Y0) turns on, the operations of all active axes will stop.</li> <li>• Stops in the deceleration time of 1 ms.</li> </ul>
Limit stop:		<ul style="list-style-type: none"> <li>• Once a limit + input and limit - input turns on, an active operation will stop and the operation of corresponding axes will stop. "Limit switch" under "Axis parameter settings" &gt; "Basic setup" should be set to "A: Enabled".</li> <li>• Performs a deceleration stop in the "limit stop deceleration time" specified in the axis parameter.</li> </ul>
Software limit stop		<ul style="list-style-type: none"> <li>• When the software limit function is effective, an active operation will stop and the corresponding axes will stop when it exceeds the range of the software limit.</li> <li>• Performs a deceleration stop in the "error stop deceleration time" specified in the axis parameter.</li> </ul>
Error stop		<ul style="list-style-type: none"> <li>• When a unit error occurs, the operation of corresponding axes (all axes or axis in which the error occurs) will stop.</li> <li>• Target axes vary depending on the selection of the parameter "MC common settings" &gt; "Operation when an error occurs".</li> <li>• Performs a deceleration stop in the "error stop deceleration time" specified in the axis parameter.</li> </ul>
Emergency stop		<ul style="list-style-type: none"> <li>• When an emergency stop request (corresponding bit allocated to UM001B0 to UM001B5) turns on an active operation will stop and the operation of corresponding axes will stop.</li> <li>• Performs a deceleration stop in the "emergency stop deceleration time" specified in the axis parameter.</li> </ul>

Name	Time chart	Occurrence condition and operation
Deceleration stop (Note 1)		<ul style="list-style-type: none"> <li>When a deceleration stop request (corresponding bit allocated to UM001B6 to UM001BB) turns on, an active operation will stop and the operation of corresponding axes will stop.</li> <li>Performs a deceleration stop in the deceleration time specified for the active positioning operation.</li> </ul>
Pause (Note 1)		<ul style="list-style-type: none"> <li>When a deceleration stop request (corresponding bit allocated to UM001B6 to UM001BB) turns on an active operation will stop and the operation of corresponding axes will stop.</li> <li>Performs a deceleration stop in the deceleration time specified for the active positioning operation.</li> <li>Once a deceleration stop signal turns off, the deceleration stop will be canceled and the stopped control will restart.</li> </ul>

(Note 1): The deceleration stop and pause operations are switched by the "MC common setting" parameter or the system operation setting area of unit memory by user programs.

■ Allocation of I/O numbers

Signal name	I/O number
System stop	Y0

(Note 1): The I/O numbers in the above table show relative addresses based on the base word number. The I/O numbers actually used vary according to the slot number where the unit is installed and the starting word number.

■ Allocation of unit memories

Signal name	Real axis				Virtual axis	
	Axes 1-16	Axes 17-32	Axes 33-48	Axes 49-64	Axes 1-16	Axes 17-32
Emergency stop request	UM001B0	UM001B1	UM001B2	UM001B3	UM001B4	UM001B5
Deceleration stop request	UM001B6	UM001B7	UM001B8	UM001B9	UM001BA	UM001BB

(Note 1): Flags or request signals for 16 axes are allocated to each unit memory (1 word) in the above table. When the value of each bit is 1, it turns on. When the value of each bit is 0, it turns off.

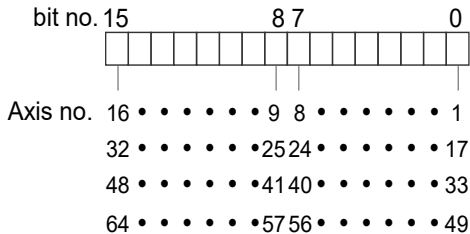

## 12.1.2 Characteristics of Pause Function

- The pause function is a function to temporarily stop the control in operation. The pause function is used by switching between the pause and deceleration stop functions.
- The pause function is used to perform the deceleration stop in the deceleration time of an active control when a deceleration stop request (corresponding bit allocated to UM001B6 to UM001BB) turns on. After that, the stopped state will be kept while the deceleration stop request is on, and the control in the stopped state will be restarted when the deceleration stop request turns off.
- The deceleration stop and pause can be switched by setting the "MC common settings" parameter using the tool software. Or the deceleration stop and pause can be switched by rewriting the unit memory (deceleration stop operation: UM0261D) in the system operation setting area using a user program.

●: Available, -: Not available

Axis no.	Unit memory no. (Hex)	Name	Default	Description	R	W
-	UM 0261D	Deceleration stop operation	H0	<p>Specify the operation when setting the deceleration stop request signal to "Active" (from off to on).</p> <p>0: Deceleration stop When performing the repeat operation, stops after reaching E-point that is targeted for the repeat operation.</p> <p>1: Pause</p> <ul style="list-style-type: none"> <li>• Performs the deceleration stop, and restarts the positioning operation when turning "Deceleration stop request signal" to off from on.</li> <li>• Also, performs the same operation as the deceleration stop in all states except during the positioning operation.</li> <li>• When performing the repeat operation, stops after reaching E-point that is targeted for the repeat operation, and restarts the positioning operation when turning "Deceleration stop request signal" to off from on.</li> <li>• If a system stop or emergency stop is executed while the positioning unit is paused, the pause state will be canceled and the operation will not restart with the deceleration stop request signal is canceled (turned off).</li> </ul>	●	●





---

**◆ KEY POINTS**

---

- **The deceleration stop cannot be executed when using the pause function. Use the emergency stop function to execute the stop operation when using the pause function.**
- **The pause function is available only when performing the automatic operation (positioning control). During a manual operation (JOG operation/home return), it is the same operation as a deceleration stop.**
- **The pause function keeps the stopped state as well as other stop functions when a deceleration stop request signal is on. If executing the emergency stop or system stop in paused state, the pause will be canceled and the state will change to the one of the emergency stop or system stop.**
- **When switching the unit memory (deceleration stop operation in the system operation setting area: UM0261D) using a user program, all axes should be stopped. While any axis is operating, the switching between the deceleration stop and pause will not be executed even if the value of the unit memory is changed.**

### 12.1.3 Stop Operation During Interpolation Control

---

- For executing the emergency stop, deceleration stop, or pause, turn on a request corresponding to the smallest axis number in an interpolation group.
- In the case of limit stop, software limit stop or error stop, the stop operation will start once a corresponding condition is established on one of axes in an interpolation group.

### 12.1.4 Stop Operation During Synchronous Control

---



#### ◆ REFERENCE

---

- For details of the stop operation during synchronous control, refer to "9.2 Settings for Master and Slave Axes" and "9.3 Start and Cancel of Synchronous Control".

## 12.2 Settings Related to Stop Function

### 12.2.1 MC Common Settings

- An operation when an error occurs is specified in the "MC common settings" dialog box.
- Specify the items in "Parameter" > "MC common settings" of CMI.

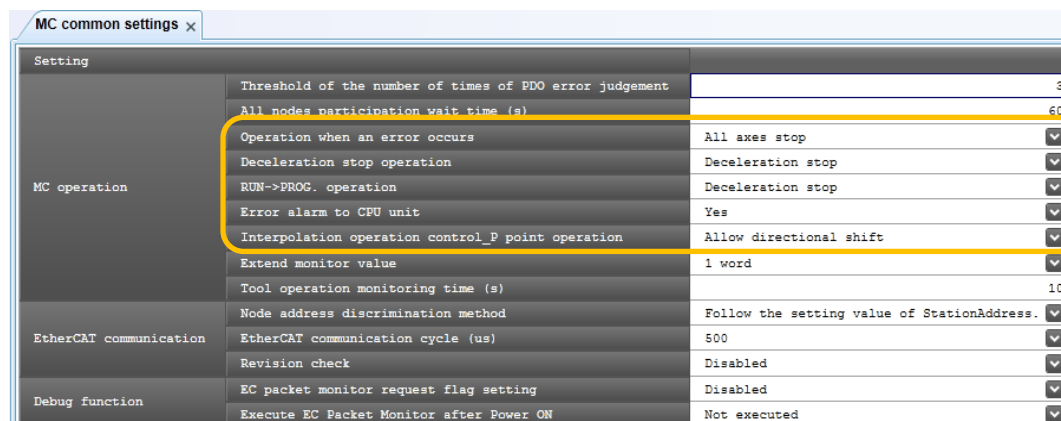

Parameter name	Default	Description	
Operation when an error occurs	All axes stop	Set the operation performed when an error occurs in axes (nodes) connected to the network.	
		All axes stop	All axes operations stop. (Note 1) Stops normal axes in the deceleration time activated when an error occurs.
		Normal axis operation continuance	The operation of the axis an error occurred stops. The operations of normal axes continue.
Deceleration stop operation	Deceleration stop	The operation when the deceleration stop request of unit memories (output control area) turns on is set. Deceleration stop / Pause	
RUN->PROG. operation	Deceleration stop	Set the operation when the operation mode of CPU unit changes from RUN to PROG.	
		Operation continuance	The operation of each axis continues.
		Deceleration stop	Each axis decelerates and stops in a specified deceleration stop time in the current control mode.
		Immediate stop	Each axis decelerates and stops in a specified emergency stop deceleration time.
Error alarm to CPU unit	Yes	Set the method of notifying errors to the CPU unit. The operation mode of the CPU unit when an error occurs is set from "CPU configuration" - "Unit error" in FPWIN GR7.	
		Yes	Announces errors to the CPU unit.
		No	Not announce errors to the CPU unit.

(Note 1): When setting "All axes stop", normal axes will stop once when an error occurs in the JOG/inching operation, however, if the JOG operation request is on after they stopped, the JOG/inching operation will start again. Create a user program to use the error annunciation flag as an interlock signal to stop the JOG/inching operation.

## 12.2.2 Axis Parameter

The time of a stop operation is specified in the axis parameter setting menu.

Specify the items in "Parameter" > "Stop function setting" > "Axis parameter settings" of CMI.

Axis		Axis 1	Axis 2
	JOG operation - Inching movement	1	1
Stop function setting	Emergency stop deceleration time (ms)	100	100
	Limit stop deceleration time (ms)	100	100
	Error stop deceleration time (ms)	100	100

Item	Default	Description
Emergency stop deceleration time	100 ms	Set the deceleration time at the time of emergency stop. 0 to 10000 ms
Limit stop deceleration time	100 ms	Set the deceleration time at the time of limit stop. 0 to 10000 ms
Error stop deceleration time	100 ms	Set the deceleration time at the time of error stop. 0 to 10000 ms

## 12.3 Operation During Stop

---

### ■ Operation during stop

- The stop request for the system stop is performed by turning on an output signal (Y0) in the I/O area. The stop requests for the emergency stop, deceleration stop and pause are performed by turning on the bits allocated to the unit memories (UM) area.
- The stopped state is held while each request signal is on until each of them turns off. Any operation cannot be activated in the stopped state. It is also the same in the cases of limit stop, software limit stop and error stop.

### ■ Priority of stop operations

- When stop control requests are made simultaneously, the stop operations are executed according to the following priority.

System stop > Limit stop > Software limit stop > Error stop > Emergency stop > Deceleration stop

### ■ Dwell time setting

- The dwell time setting is invalid in the stop operations regardless of operation patterns.
- However, the dwell time setting is valid in the positioning operation after a pause.

### ■ Flag processing

- In the case of system stop, the busy flag turns off and the operation done flag turns on.
- In the cases of emergency stop, limit stop, software limit stop, error stop and deceleration stop, the busy flag turns off and the operation done flag turns on after the completion of deceleration.

### ■ Current value coordinate

- Even in a stop operation, the current value coordinate area is always updated.
- After the emergency stop, limit stop, software limit stop, error stop, deceleration stop or pause, deceleration is performed in each specified deceleration time, and values at the time of stop are stored.
- In the case of system stop, the value at the time of stop is stored.

### ■ Operation when home return operation is performed

- For the home return methods which are based on the home position (Z phase) (i.e. DOG method 1, DOG method 3, Limit method 1, Z phase method and Stop-on-contact method 2), the home return operation after shifting to the creep speed is controlled by the servo amplifier A6B/A5B. During this operation, the high-order PLC (FP7 MC Unit) cannot control the operation. Please design and evaluate the system to avoid any danger even after shifting to the creep speed.



# 13

## Supplementary Functions

## 13.1 Software Limit

The system is designed to mechanically set the limit (+) and limit (-) to restrict the moving range of a motor.

Separately from the mechanical limits (+) and (-), the software limit is a function to add the limits on software for the absolute coordinate managed within the unit. As the software limit is a function for the protection of motors and servo amplifiers, it is recommended to set them to the values within the range of the mechanical limits (+) and (-) as below.

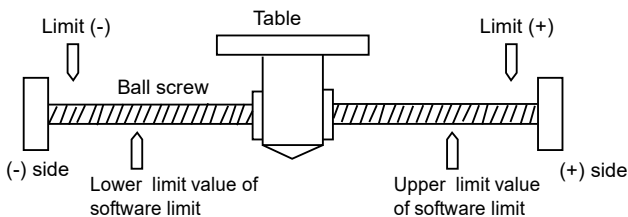

When exceeding the setting range of the software limit (upper and lower limit values), an error occurs, and the deceleration stop is executed. It is necessary to clear the error and move the motor into the range of the software limit using an operation such as JOG operation after the stop.

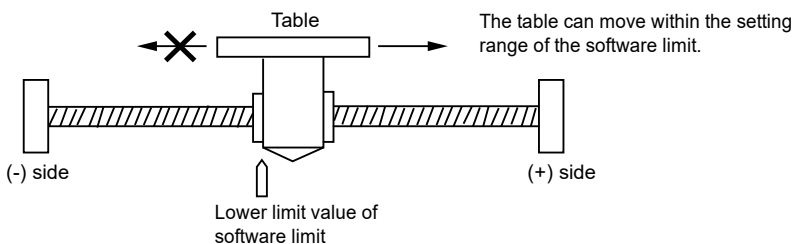

Whether the software limit is set to be available or not can be specified individually for the positioning control, JOG operation and home return each. For example, it is possible to set the limit software to be invalid only in the home return operation.



## 13.2 Current Value Update

The current value update is a function to set the "current value after unit conversion" stored in the unit memories within FP7 MC Unit to an arbitrary value.

- A value is set in the current value update coordinate area (UM005A0 to UM0065F) in the unit memories as a current value using a user program.
- The "current value after unit conversion" of each axis information area is changed to the specified current value by turning on the bit of a target axis in the current value update request flag area (UM00590 to UM00595).

### ■ Program example

When changing the current position of the 1st axis to 100,000, the following figure shows a program to preset an arbitrary value "K100000" in the current value update area in the unit memories and update the value for the current value after unit conversion of 1st axis.

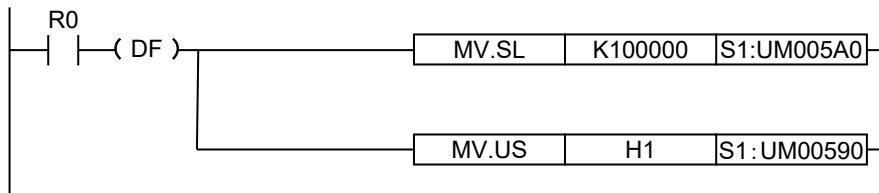

### ◆ KEY POINTS

- The "current value after unit conversion" area in the unit memories is updated by the "current value update" function. Values in the "AMP current value" area are not updated.
- An integer equivalent to the current value after unit conversion is set to the unit memory.  
Example) When the unit is  $\mu\text{m}$  (0.1  $\mu\text{m}$ ), set to "10000" for making it be 1000.0  $\mu\text{m}$ .

■ Current value update data area (Unit memories)

Axis no.	Unit memory no. (Hex)	Name	Default	Description	
Axes 1-16	UM 00590	Current value update request	H0	Only when the corresponding bit for each axis changes to 1 from 0, the current value coordinate controlled by FP7 MC Unit are changed to the current value update coordinate. After the change, FP7 MC Unit clears the corresponding bits to 0 automatically.	
Axes 17-32	UM 00591				
Axes 33-48	UM 00592				
Axes 49-64	UM 00593				
Virtual axes 1-16	UM 00594				
Virtual axes 17-32	UM 00595				
bit	Name				Description
0	Axis 1+16n: Current value update request				0: No change 1: Update the current value after unit conversion of a target axis
1	Axis 2+16n: Current value update request				
2	Axis 3+16n: Current value update request				
3	Axis 4+16n: Current value update request				
4	Axis 5+16n: Current value update request				
5	Axis 6+16n: Current value update request				
6	Axis 7+16n: Current value update request				
7	Axis 8+16n: Current value update request				
8	Axis 9+16n: Current value update request				
9	Axis 10+16n: Current value update request				
10	Axis 11+16n: Current value update request				
11	Axis 12+16n: Current value update request				
12	Axis 13+16n: Current value update request				
13	Axis 14+16n: Current value update request				
14	Axis 15+16n: Current value update request				
15	Axis 16+16n: Current value update request				
Axis 1	UM 005A0 - UM 005A1	Current value update coordinate	K0	Stores the coordinate value to be preset as the current value after unit conversion. Range: -2,147,483,648 to 2,147,483,647 The ranges vary depending on the unit settings as below. pulse: -2,147,483,648 to 2,147,483,647 pulses μm (0.1μm): -214,748,364.8 to 214,748,364.7 μm μm (1μm): -2,147,483,648 to 2,147,483,647 μm inch (0.00001 inch): -21,474.83648 to 21,474.83647 inches inch (0.0001 inch): -214,748.3648 to 214,748.3647 inches degree (0.1 degree): -214,748,364.8 to 214,748,364.7 degrees degree (1 degree): -2,147,483,648 to 2,147,483,647 degrees An integer equivalent to the current value after unit conversion is set to the unit memories. Example) When the unit is μm (0.1 μm), set to "10000" for making it be 1,000.0 μm.	
Axis 2	UM 005A2 - UM 005A3				
Virtual axis 1	UM 00620 - UM 00621				
	-				
Virtual axis 32	UM 0065E - UM 0065F				

(Note 1): Request signals for 16 axes are allocated to each area (1 word) of current value update request. When the value of each bit is 1, it turns on. When the value of each bit is 0, it turns off.

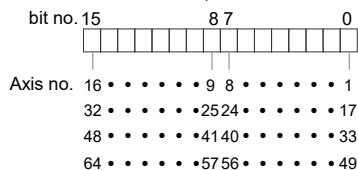

(Note 2): As for the unit memory in which the current value update coordinate is set, 2-word area is allocated for each axis.

## 13.3 Home Coordinates

The home coordinates is a function to set the coordinates after the home return processing to arbitrary values.

- The coordinates after the home return processing can be set in the "Axis parameter settings" dialog box of CMI or user programs.
- Set coordinates become the home coordinates by executing the home return for target axes.

### ■ Setting of home coordinates

The home coordinates can be set for each axis in the "Axis parameter settings" dialog box of CMI.

Axis parameter settings* x		Axis 1 [Group 1]	Axis 2 [Group 1]	Axis 3 [Group 1]
Home return setting	Return setting code	5: Z-phase method	5: Z-phase method	5: Z-phase method
	Home position proximity logic	0:Normal Open (A contact)	0:Normal Open (A contact)	0:Normal Open (A contact)
	Stop-on-contact torque value (%)	100	100	100
	Stop-on-contact judgment time (ms)	100	100	100
	Return direction	0:Limit (-) direction	0:Limit (-) direction	0:Limit (-) direction
	Return acceleration time	10	10	10
	Return deceleration time	50	50	50
	Return target speed	2000000	2000000	2000000
	Return creep speed	500000	500000	500000
	Home coordinates	0	0	0

### Program example

When the current value of the first axis is returned after the home return, the current value after system conversion of the first axis is read and set as home coordinates, and the home return is requested.

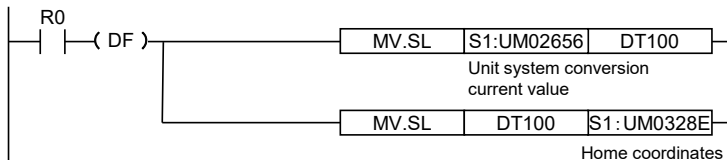

■ Home coordinates area (Unit memories)

Axis no.	Unit memory no. (Hex)	Name	Default	Description
Axis 1	UM 0328E - UM 0328F	Home coordinates	K0	Set the home coordinates to be set after the completion of the home return. Range: -2,147,483,648 to 2,147,483,647  The ranges vary depending on the unit settings as below. pulse: -2,147,483,648 to 2,147,483,647 pulses $\mu\text{m}$ (0.1 $\mu\text{m}$ ): -214,748,364.8 to 214,748,364.7 $\mu\text{m}$ $\mu\text{m}$ (1 $\mu\text{m}$ ): -2,147,483,648 to 2,147,483,647 $\mu\text{m}$ inch (0.00001 inch): -21,474.83648 to 21,474.83647 inches inch (0.0001 inch): -214,748.3648 to 214,748.3647 inches degree (0.1 degree): -214,748,364.8 to 214,748,364.7 degrees degree (1 degree): -2,147,483,648 to 2,147,483,647 degrees  An integer equivalent to the current value after unit conversion is set to the unit memory.  Example) When the unit is $\mu\text{m}$ (0.1 $\mu\text{m}$ ), set to "10000" for making it be 1000.0 $\mu\text{m}$ .
-	-			
Axis 2	UM 0330E - UM 0330F			
-	-			
Axis 64	UM 0520E - UM 0520F			
-	-			
Virtual axis 1	UM 0528E - UM 0528F			
-	-			
Virtual axis 32	UM 0620E - UM 0620F			

(Note 1): As for the unit memories in which the home coordinates are set, 2-word area is allocated for each axis.

(Note 2): The difference between the unit memory number of the target axis number and the unit memory number of the adjacent axis number is H80 (for 128 words).



◆ KEY POINTS

- **An integer equivalent to the current value after unit conversion is set for home coordinates.**  
**Example) When the unit is  $\mu\text{m}$  (0.1  $\mu\text{m}$ ), set to "10000" for making it be 1000.0  $\mu\text{m}$ .**

## 13.4 Movement Amount Automatic Check

The movement amount automatic check function is used to check if axes are operating in conformity to command values. The check function is used to generate an error or warning on the FP7 MC Unit side when the difference (deviation) between the command value and the current value after unit conversion controlled in FP7 MC Unit exceeds a set movement check value.

- The movement amount automatic check is set in the "Axis parameter settings" menu of CMI. Movement check values can be set by respective axes.
- When an error occurs, the operation will stop in the "error stop deceleration time, and cannot be executed until the error is cleared. When a warning occurs, only the occurrence of warning will be informed, and the operation will continue.

### ■ Parameter setting by CMI

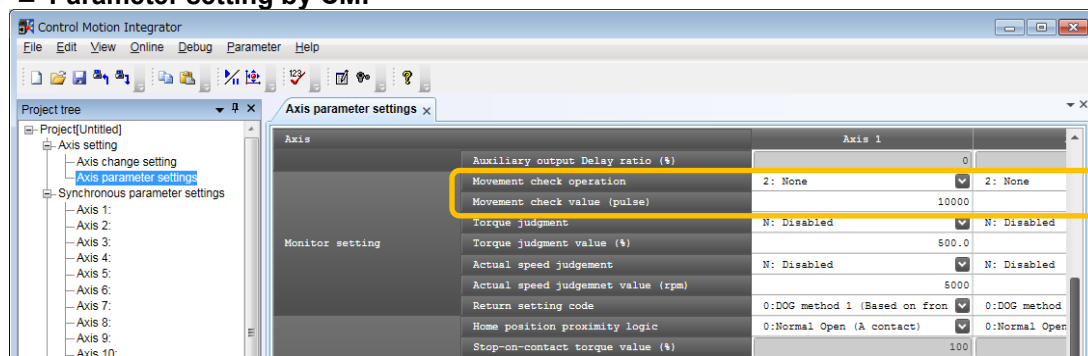

Parameter name	Default	Description
Movement check operation	2: None	Select the operation when exceeding the movement check value. 0: Error, 1: Warning, 2: None
Movement check value (pulse)	10000	Set the threshold for the movement amount automatic check operation. For 1 word: Range: 0 to 65535 For 2 words: Range: 0 to 2147483647



### ◆ REFERENCE

- For details of errors and warnings, refer to "15 Troubleshooting".

■ **Operation of movement amount automatic check function**

The movement amount automatic check function is activated by the following procedure during all operations.

①	Stores command values for AMP in FP7 MC Unit simultaneously when starting an operation for each communication period.
②	Compares the previous command value (stored in FP7 MC Unit) and the current value after unit conversion for each communication period, and checks whether the difference (deviation) exceeds the set movement check value or not.
③	Stores the current value held by FP7 MC Unit within FP7 MC Unit.
④	Subsequently, repeats the above ② and ③.

■ **Position deviation monitor**

The value (deviation) calculated by the movement amount automatic check function can be confirmed by a ladder program. For monitoring the position deviation, the following unit memory area is used.

●: Available, -: Not available

Axis number	Unit memory no. (Hex)	Name	Description	R	W
1	UM 0264E -UM 0264F	Position deviation	Stores the difference value between the value of the position specified in FP7 MC Unit and the value of the position fed back from the amplifier.	●	-

(Note): The above unit memory numbers are those for the axis number 1.

## 13.5 Completion Width

It is used to set the timing to turn on the operation done flag allocated to the I/O of FP7 MC Unit.

- The operation done flag turns on when the AMP current value (UM02654 to UM02655) is in the range of the +/- completion width (pulse) of the target command position after the completion of the pulse command output.
- The completion width is monitored by FP7 MC Unit unlike the position deviation of AMP.
- The completion width function is set in the following unit memories.

Axis no.	Unit memory no. (Hex)	Name	Default	Unit	Description
Axis 1	UM 03257	Completion width check time	U0	ms	Specify the width of the completion of command operation. Range: 0 to 10,000 (ms) Any other settings will be errors. When "0" is set, the completion width is not checked.
Axis 2	UM 032D7				
:	:				
Virtual axis 1	UM 05257				
:	:				
Virtual axis 32	UM 061D7	Completion width	U10	pulse	Turns on the completion flag when the AMP current value [feedback value] becomes within this completion width after the movement of a set amount during the positioning control, JOG operation. Range: 1 to 2,147,483,647 Any other settings will be errors.
Axis 1	UM 0325A to UM 0325B				
Axis 2	UM 032DA - UM 032DB				
:	:				
Virtual axis 1	UM 0525A to UM 0525B				
:	:				
Virtual axis 32	UM 061DA -UM 061DB				

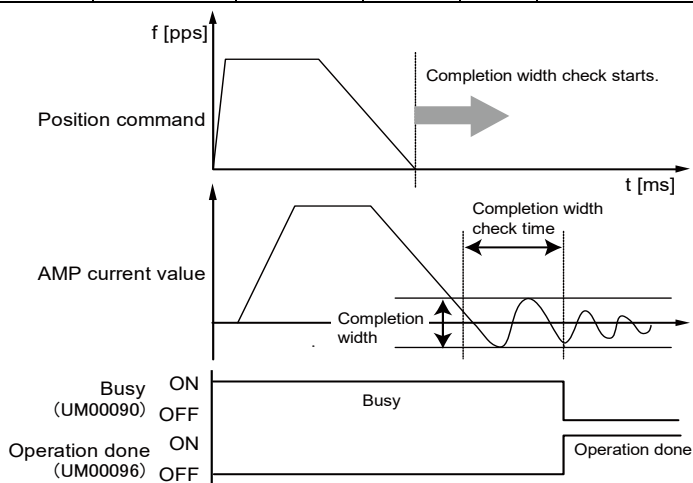

## 13.6 Monitor Value Judgement

This is a function to monitor the actual speed/torque of AMP and generate an error or warning on the FP7 MC Unit side when it exceeds a set judgement value.

When an error occurs, the operation will stop in the "error stop deceleration time, and a next operation cannot be executed until the error is cleared. When a warning occurs, only the occurrence of warning will be informed, and the operation will continue.

The monitor value judgement function is set in the following unit memories.

Axis no.	Unit memory no. (Hex)	Name	Default	Description																					
Axis 1	UM 0325C	Monitor value error setting	H0	The judgement values for torque monitor values and execution speed of each axis can be set to announce errors or warnings. <table border="1"> <thead> <tr> <th>bit.</th> <th>Name</th> <th>Description</th> </tr> </thead> <tbody> <tr> <td>0</td> <td>Torque judgment enabled</td> <td>0: Disables the torque judgment value. 1: Enables the torque judgment value.</td> </tr> <tr> <td>1</td> <td>Torque judgment value error/warning setting</td> <td>0: Announces an error when it is enabled. 1: Announces a warning when it is enabled.</td> </tr> <tr> <td>2</td> <td>Actual speed judgment value enabled</td> <td>0: Disables the actual speed judgment value. 1: Enables the actual speed judgment value.</td> </tr> <tr> <td>3</td> <td>Actual speed judgment value error/warning setting</td> <td>0: Announces an error when it is enabled. 1: Announces a warning when it is enabled.</td> </tr> <tr> <td>4</td> <td>Actual speed judgement (unit)</td> <td>0: 0.1 rpm 1: Command unit/s</td> </tr> <tr> <td>15-5</td> <td>-</td> <td>-</td> </tr> </tbody> </table>	bit.	Name	Description	0	Torque judgment enabled	0: Disables the torque judgment value. 1: Enables the torque judgment value.	1	Torque judgment value error/warning setting	0: Announces an error when it is enabled. 1: Announces a warning when it is enabled.	2	Actual speed judgment value enabled	0: Disables the actual speed judgment value. 1: Enables the actual speed judgment value.	3	Actual speed judgment value error/warning setting	0: Announces an error when it is enabled. 1: Announces a warning when it is enabled.	4	Actual speed judgement (unit)	0: 0.1 rpm 1: Command unit/s	15-5	-	-
bit.	Name				Description																				
0	Torque judgment enabled				0: Disables the torque judgment value. 1: Enables the torque judgment value.																				
1	Torque judgment value error/warning setting				0: Announces an error when it is enabled. 1: Announces a warning when it is enabled.																				
2	Actual speed judgment value enabled				0: Disables the actual speed judgment value. 1: Enables the actual speed judgment value.																				
3	Actual speed judgment value error/warning setting				0: Announces an error when it is enabled. 1: Announces a warning when it is enabled.																				
4	Actual speed judgement (unit)				0: 0.1 rpm 1: Command unit/s																				
15-5	-	-																							
Axis 2	UM 032DC																								
:	:																								
Axis 32	UM 041DC																								
:	:																								
Axis 64	UM 051DC																								
Axis 1	UM 0325D	Torque judgement value	U5000	Set the limit of the torque. Range: 0 to 5000 (0.0% to 500.0%) Any other settings will be errors. Set the limit of the torque.																					
Axis 2	UM 032DD																								
:	:																								
Axis 32	UM 041DD																								
Axis 64	UM 051DD																								
Axis 1	UM 0325E -UM 0325F	Actual speed judgement value	U5000	Set the limit of the actual speed as integer. <table border="1"> <thead> <tr> <th>Extend monitor value (Note 2)</th> <th>Monitor error unit (Note 1)</th> <th>Range</th> </tr> </thead> <tbody> <tr> <td>1 word</td> <td>1 rpm</td> <td>0 to 5000 rpm</td> </tr> <tr> <td rowspan="2">2 words</td> <td>0.1 rpm</td> <td>0 to 6,500.0 rpm</td> </tr> <tr> <td>Command unit/s</td> <td>0 to 2147483647 command unit/s</td> </tr> </tbody> </table>	Extend monitor value (Note 2)	Monitor error unit (Note 1)	Range	1 word	1 rpm	0 to 5000 rpm	2 words	0.1 rpm	0 to 6,500.0 rpm	Command unit/s	0 to 2147483647 command unit/s										
Extend monitor value (Note 2)	Monitor error unit (Note 1)				Range																				
1 word	1 rpm				0 to 5000 rpm																				
2 words	0.1 rpm				0 to 6,500.0 rpm																				
	Command unit/s				0 to 2147483647 command unit/s																				
Axis 2	UM 032DE -UM 032DF																								
:	:																								
Axis 32	UM 041DE -UM 041DF																								
Axis 64	UM 051DE -UM 051DF																								

(Note 1): The actual speed judgement (unit) setting of monitor value error setting is available since FP7 MC Unit Ver.1.20.

(Note 2): The extension to the monitor value of 2 words is available since FP7 MC Unit Ver.1.20. It is set by changing "Extend monitor value" in MC common settings of CMI configuration to "2words".



### 13.6.1 Torque Judgement

This is a function to generate an error or warning when a torque value exceeds the torque judgement value (UM0325D) when the monitor value error setting (UM0325C) is set to "H1 (Error annunciation)" or "H3 (Warning annunciation)".

The torque monitor values can be confirmed in the following unit memory area.

Axis no.	Unit memory no. (Hex)	Name	Default	Unit	Setting range and description						
Axis 1	UM 0264C	Torque monitor value	-	0.1%	Stores the torque monitor values. <table border="1"> <thead> <tr> <th>bit.</th> <th>Name</th> <th>Description</th> </tr> </thead> <tbody> <tr> <td>15-0</td> <td>Torque command value</td> <td>Range: 0 to 5000 (0.0% to 500.0%)</td> </tr> </tbody> </table> Although the torque command value is specified as an absolute value, the monitor value is displayed like "-500.0 to +500.0" to indicate the direction.	bit.	Name	Description	15-0	Torque command value	Range: 0 to 5000 (0.0% to 500.0%)
bit.	Name					Description					
15-0	Torque command value					Range: 0 to 5000 (0.0% to 500.0%)					
Axis 2	UM 0266C										
:	:										
Axis 32	UM 02A2C										
Axis 64	UM 02E2C										

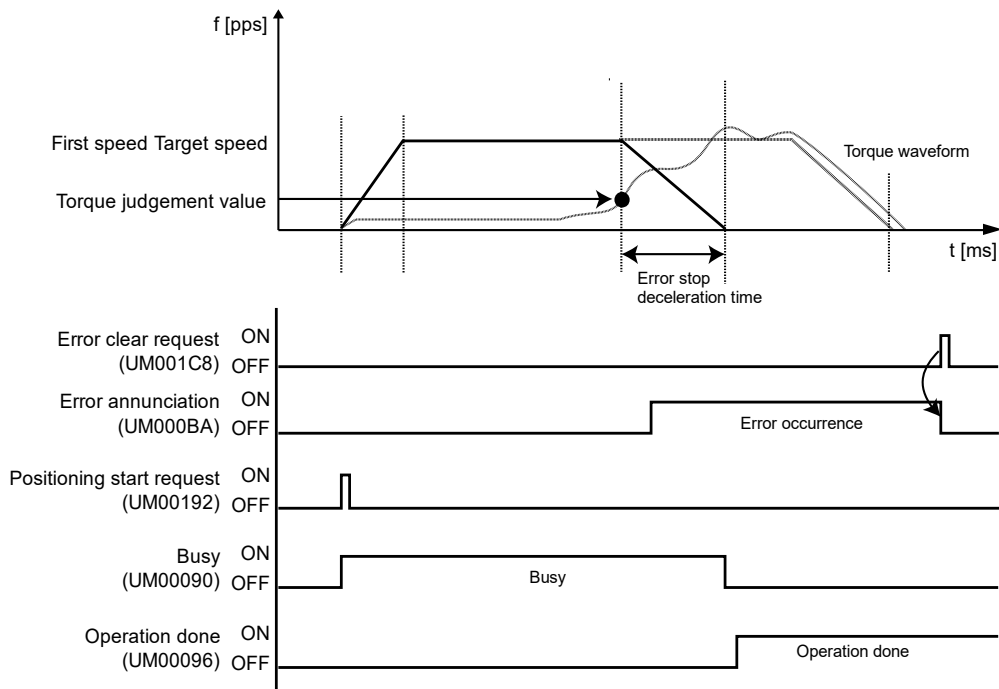

■ **Errors and Warnings**

**[Monitor value error setting (UM0325C): 0x1 (Error annunciation)]**

**Axis operation error [From 00F0 3000H]**

●: Recoverable, -: Unrecoverable

Error code	Error name	Description	Object	Recovered	Countermeasures
3050H	Torque judgment error	The torque value exceeds the setting torque monitor judgement value.	Each axis	●	<ul style="list-style-type: none"> <li>- Design the system within the range that the torque of the motor does not exceed the judgment value.</li> <li>- Check the torque monitor judgment value.</li> </ul>

(Note): To simplify the displays, only the lower four digits (Hex) of each error code are displayed in the above table.

**[Monitor value error setting (UM0325C): 0x3 (Warning annunciation)]**

**Unit warning [From 00B0 0000H]**

●: Recoverable, -: Unrecoverable

Warning code	Name	Description	Object	Recovered	Countermeasures
0050H	Torque judgment warning	The torque value exceeds the setting torque monitor judgement value.	Each axis	●	<ul style="list-style-type: none"> <li>- Design the system within the range that the torque of the motor does not exceed the judgment value.</li> <li>- Check the torque monitor judgment value.</li> </ul>

### 13.6.2 Actual Speed Judgement

This is a function to generate an error or warning when the actual speed exceeds the actual speed judgement value (UM0325E to UM0325F) when the monitor value error setting (UM0325C) is set to "0x4 (Error annunciation)" or "0xC (Warning annunciation)".

The actual speed can be confirmed in the following unit memory area. The confirmation areas of actual speed values vary according to the setting of "Extend monitor value" in MC common settings of CMI (shown below).

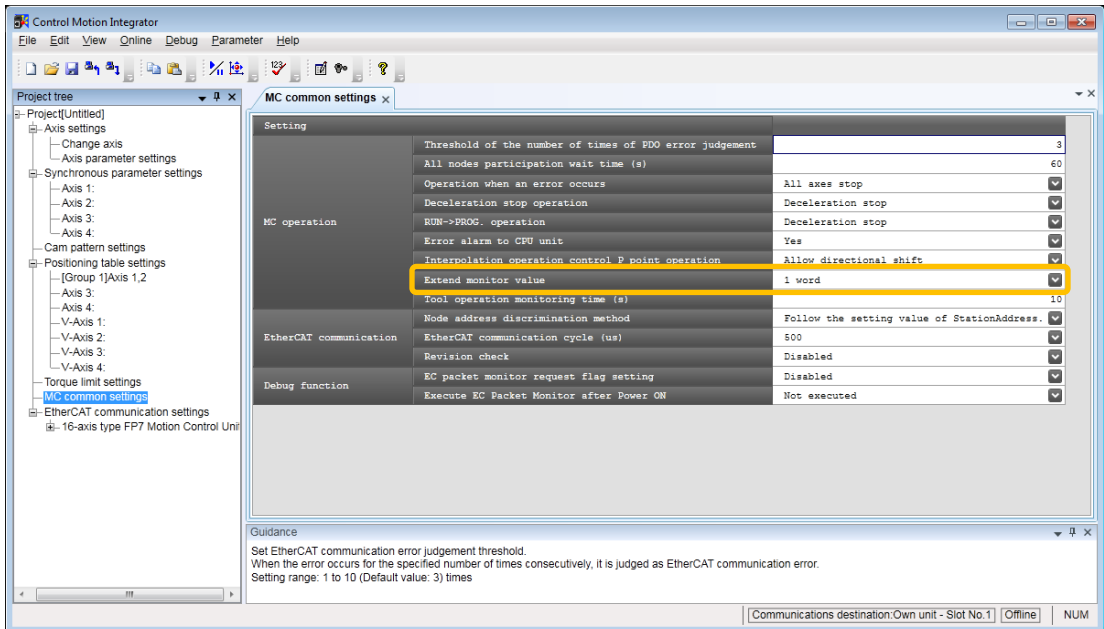

■ When "Extend monitor value" in the system operation setting area is set to 1 word

Axis no.	Unit memory no. (Hex)	Name	Default	Unit	Description						
Axis 1	UM 0264D	Actual speed monitor value	-	1 rpm	The actual speed monitor value is stored. <table border="1" style="width: 100%;"> <thead> <tr> <th>bit.</th> <th>Name</th> <th>Description</th> </tr> </thead> <tbody> <tr> <td>15-0</td> <td>Actual speed</td> <td>Setting range: 0 to 5,000</td> </tr> </tbody> </table> * When "Extend monitor value" in MC common settings is set to "2 words", this area is always "0". However, if the setting of "Extend monitor value" in the system operation setting area is changed during operation, the changed value is held. Although the actual speed command value is specified as an absolute value, the monitor value is displayed like "- 5,000 to +5,000" to indicate the direction.	bit.	Name	Description	15-0	Actual speed	Setting range: 0 to 5,000
bit.	Name					Description					
15-0	Actual speed					Setting range: 0 to 5,000					
Axis 2	UM 0266D										
:	:										
Axis 32	UM 02A2D										
:	:										
Axis 64	UM 02E2D										

■ When "Extend monitor value" in the system operation setting area is set to 2words

Axis no.	Unit memory no. (Hex)	Name	Default	Unit	Description						
Axis 1	UM 00770 -UM 00771	Actual speed monitor value [2words]	-	0.1 rpm / Command unit/s	The actual speed monitor value is stored. <table border="1" style="width: 100%;"> <thead> <tr> <th>bit.</th> <th>Name</th> <th>Description</th> </tr> </thead> <tbody> <tr> <td>31-0</td> <td>Actual speed</td> <td>Setting range: 0 to 2,147,483,647</td> </tr> </tbody> </table> * When "Extend monitor value" in MC common settings is set to "1 word", this area is always "0". However, if the setting of "Extend monitor value" in the system operation setting area is changed during operation, the changed value is held. Although the actual speed command value is specified as an absolute value, the monitor value is displayed like "-2,147,483,648 to 2,147,483,647" to indicate the direction.	bit.	Name	Description	31-0	Actual speed	Setting range: 0 to 2,147,483,647
bit.	Name					Description					
31-0	Actual speed					Setting range: 0 to 2,147,483,647					
Axis 2	UM 00772 -UM 00773										
:	:										
Axis 32	UM 007AE -UM 007AF										
:	:										
Axis 64	UM 007EE -UM 007EF										

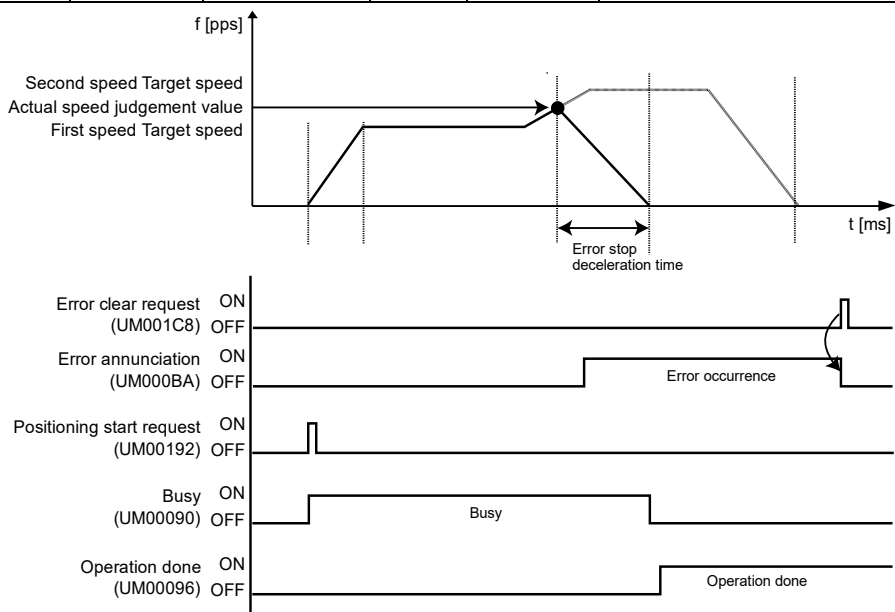

### ■ Errors and Warnings

#### [Monitor value error setting (UM0325C): 0x4 (Error annunciation)]

##### Axis operation error [From 00F0 3000H]

Error code	Error name	Description	Object	Recovered	Countermeasures
3051H	Actual speed judgment value error	The actual speed exceeds the setting actual speed monitor judgement value.	Each axis	●	Design the system within the range that the actual speed of the motor does not exceed the judgment value. Check the actual speed monitor judgment value.

#### [Monitor value error setting (UM0325C): 0xC (Warning annunciation)]

##### Unit warning [From 00B0 0000H]

Error code	Error name	Description	Object	Recovered	Countermeasures
0051H	Actual speed judgment value warning	The monitored actual speed exceeded the specified upper/lower limit value.	Each axis	●	- Design the system within the range that the actual speed of the motor does not exceed the judgment value. - Check the actual speed judgement value.

## 13.7 Torque Limit

FP7 MC Unit supports a function (torque limit) to change the maximum torque for the AMP in real time.

The torque limit can be arbitrarily changed when this unit is operating. However, the torque limit cannot be changed in the home return operation.

The specified torque limit value is used as the maximum torque during the torque limit operation. Also, the torque limit cannot be set by the setting tool "Control Motion Integrator" because it is a function that can be changed when the unit is operating. Data must be written into the unit from PLC to perform the torque limit. The descriptions of the unit memories to perform the torque limit are as follows.

Axis no.	Unit memory no. (Hex)	Name	Default	Unit	Setting range and description																																				
Axes 1-16	UM 00720	Torque limit enable flag	H0	-	Set the corresponding bits of axes for the torque limit to "1". <table border="1" style="width: 100%; border-collapse: collapse;"> <thead> <tr> <th>bit.</th> <th>Name</th> <th>Description</th> </tr> </thead> <tbody> <tr><td>0</td><td>Axes 1+16n Torque limit enabled</td><td rowspan="16">0: Torque limit disabled 1: Torque limit enabled</td></tr> <tr><td>1</td><td>Axes 2+16n Torque limit enabled</td></tr> <tr><td>2</td><td>Axes 3+16n Torque limit enabled</td></tr> <tr><td>3</td><td>Axes 4+16n Torque limit enabled</td></tr> <tr><td>4</td><td>Axes 5+16n Torque limit enabled</td></tr> <tr><td>5</td><td>Axes 6+16n Torque limit enabled</td></tr> <tr><td>6</td><td>Axes 7+16n Torque limit enabled</td></tr> <tr><td>7</td><td>Axes 8+16n Torque limit enabled</td></tr> <tr><td>8</td><td>Axes 9+16n Torque limit enabled</td></tr> <tr><td>9</td><td>Axes 10+16n Torque limit enabled</td></tr> <tr><td>10</td><td>Axes 11+16n Torque limit enabled</td></tr> <tr><td>11</td><td>Axes 12+16n Torque limit enabled</td></tr> <tr><td>12</td><td>Axes 13+16n Torque limit enabled</td></tr> <tr><td>13</td><td>Axes 14+16n Torque limit enabled</td></tr> <tr><td>14</td><td>Axes 15+16n Torque limit enabled</td></tr> <tr><td>15</td><td>Axes 16+16n Torque limit enabled</td></tr> </tbody> </table>	bit.	Name	Description	0	Axes 1+16n Torque limit enabled	0: Torque limit disabled 1: Torque limit enabled	1	Axes 2+16n Torque limit enabled	2	Axes 3+16n Torque limit enabled	3	Axes 4+16n Torque limit enabled	4	Axes 5+16n Torque limit enabled	5	Axes 6+16n Torque limit enabled	6	Axes 7+16n Torque limit enabled	7	Axes 8+16n Torque limit enabled	8	Axes 9+16n Torque limit enabled	9	Axes 10+16n Torque limit enabled	10	Axes 11+16n Torque limit enabled	11	Axes 12+16n Torque limit enabled	12	Axes 13+16n Torque limit enabled	13	Axes 14+16n Torque limit enabled	14	Axes 15+16n Torque limit enabled	15	Axes 16+16n Torque limit enabled
bit.	Name					Description																																			
0	Axes 1+16n Torque limit enabled					0: Torque limit disabled 1: Torque limit enabled																																			
1	Axes 2+16n Torque limit enabled																																								
2	Axes 3+16n Torque limit enabled																																								
3	Axes 4+16n Torque limit enabled																																								
4	Axes 5+16n Torque limit enabled																																								
5	Axes 6+16n Torque limit enabled																																								
6	Axes 7+16n Torque limit enabled																																								
7	Axes 8+16n Torque limit enabled																																								
8	Axes 9+16n Torque limit enabled																																								
9	Axes 10+16n Torque limit enabled																																								
10	Axes 11+16n Torque limit enabled																																								
11	Axes 12+16n Torque limit enabled																																								
12	Axes 13+16n Torque limit enabled																																								
13	Axes 14+16n Torque limit enabled																																								
14	Axes 15+16n Torque limit enabled																																								
15	Axes 16+16n Torque limit enabled																																								
Axes 17-32	UM 00721																																								
Axes 33-48	UM 00722																																								
Axes 49-64	UM 00723																																								
Axis 1	UM 00724	Torque limit value	U3000	0.1%	Set the torque limit values. If "2000" is written in this area, it operates with "2000 x 0.1 = 200 (%)" as the maximum torque. <table border="1" style="width: 100%; border-collapse: collapse;"> <thead> <tr> <th>bit.</th> <th>Name</th> <th>Description</th> </tr> </thead> <tbody> <tr> <td>15-0</td> <td>Torque limit value</td> <td>Setting range: 0.1 to 500.0</td> </tr> </tbody> </table>	bit.	Name	Description	15-0	Torque limit value	Setting range: 0.1 to 500.0																														
bit.	Name					Description																																			
15-0	Torque limit value					Setting range: 0.1 to 500.0																																			
Axis 2	UM 00725																																								
:	:																																								
Axis 32	UM 00743																																								
:	:																																								
Axis 64	UM 00763																																								

For confirming the current torque monitor value of AMP, data is stored in the following unit memory area.

Axis no.	Unit memory no. (Hex)	Name	Default	Unit	Setting range and description						
Axis 1	UM 0264C	Torque monitor value	-	0.1%	Stores the torque monitor values. <table border="1"> <thead> <tr> <th>bit.</th> <th>Name</th> <th>Description</th> </tr> </thead> <tbody> <tr> <td>15-0</td> <td>Torque command value</td> <td>Setting range: 0 to 5000</td> </tr> </tbody> </table>	bit.	Name	Description	15-0	Torque command value	Setting range: 0 to 5000
bit.	Name					Description					
15-0	Torque command value					Setting range: 0 to 5000					
Axis 2	UM 0266C										
:	:										
Axis 32	UM 02A2C										
:	:										
Axis 64	UM 02E2C										

### 13.7.1 Restrictions on Torque Limit

- The torque limit function cannot be used for the home return operation.
- As a parameter of AMP "Primary torque limit value" is used, do not change the used torque limit by PANATERM, when using the torque limit.

## 13.8 EtherCAT Communication Setting

### 13.8.1 EtherCAT Configurator

EtherCAT Configurator is a menu to configure a system and set parameters of EtherCAT communication on CMI.

#### ■ Configuration of EtherCAT Configurator

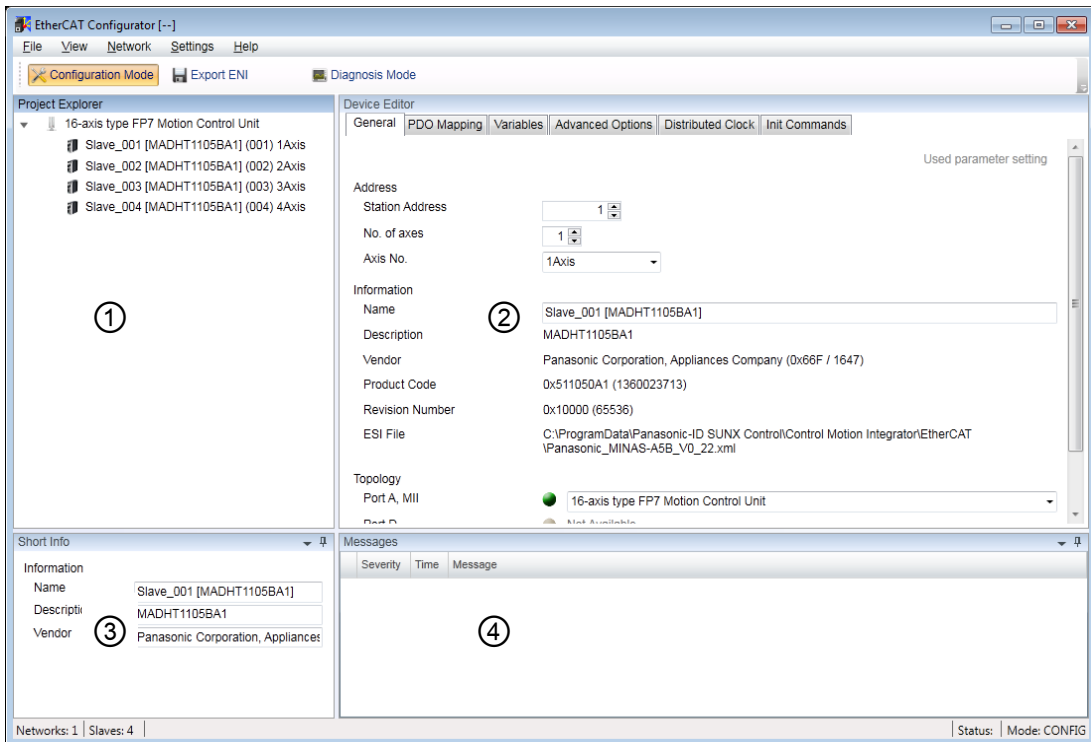

#### ■ Names and functions

No.	Name	Description
①	Project Explorer	Registered slaves (Servo Amplifier A6B/A5B) are displayed. The slaves are connected in the connection order from the slave closest to FP7 MC Unit.
②	Device Editor	Three tabs are available.
	General	Addresses are set. Information registered in the ESI file and connection states are displayed.
	PDO Mapping	Information on the PDO map of EtherCAT communication can be monitored.
	Distributed Clocks	The setting state of Distributed Clocks can be monitored.
③	Short Info	The attribute information on slaves can be monitored.
④	Message	Messages are displayed.



## 13.8.2 Device Editor

Registered slaves and parameter information can be confirmed in the device editor.

### ■ "General" tab

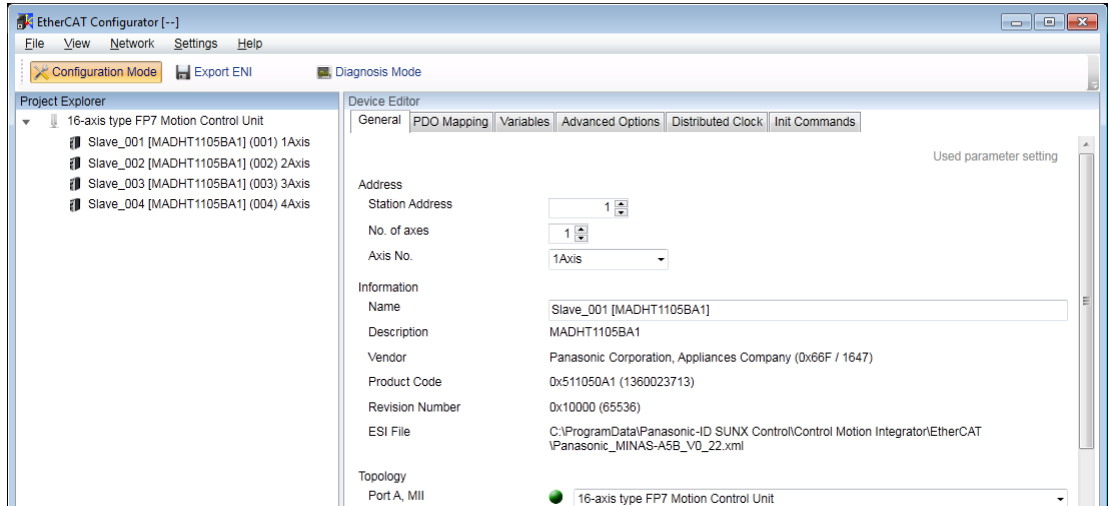

The address, axis number settings and information on ESI files and topology are displayed.

### ■ "Distributed Clock" tab

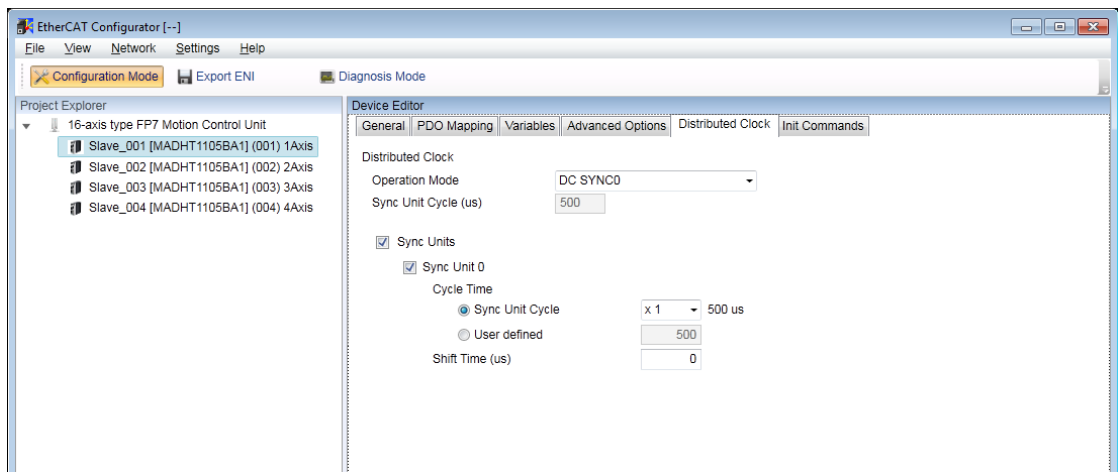

The communication cycle of synchronous unit is "EtherCAT communication cycle". The communication cycle of synchronous unit is set in the "MC common settings" of CMI not in this screen.

### 13.8.3 Overview of PDO Mapping

PDO (process data object) is data updated for each communication cycle via EtherCAT. "PDO Mapping" can be confirmed in the device editor of CMI "EtherCAT Configurator".

#### ■ PDO Mapping4

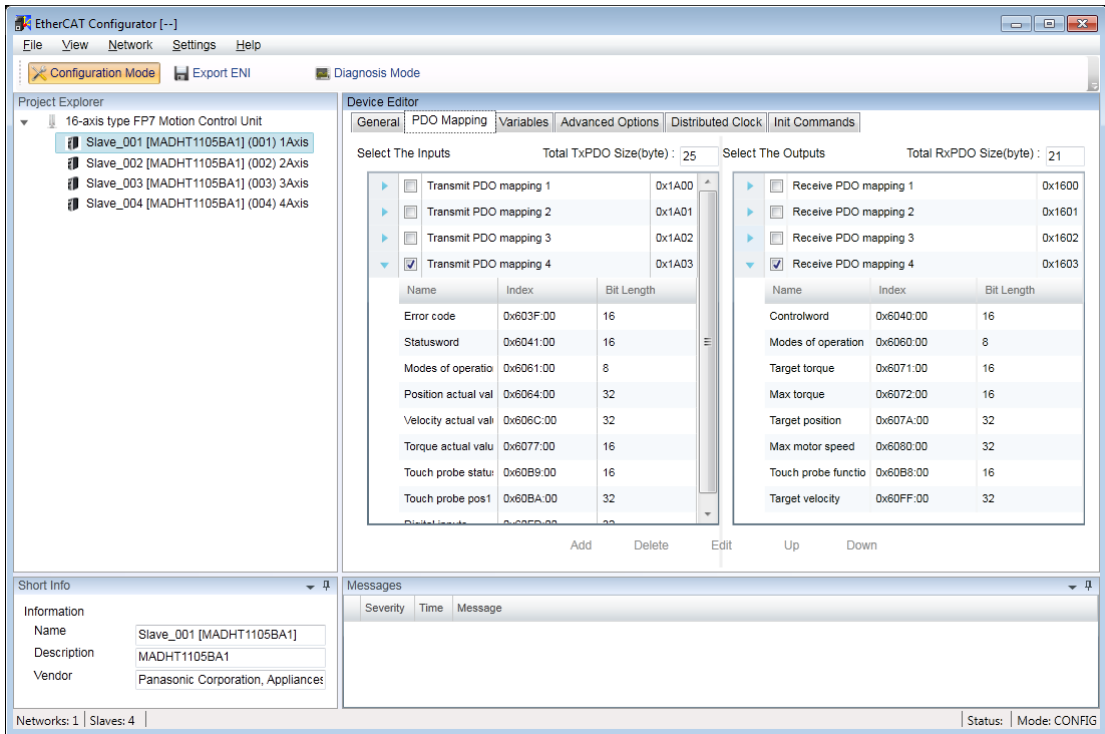

### ■ PDO mapping tab

Item	Description
Select The Inputs	The map of (input) data that is sent by Servo Amplifier A6B/A5B and received by FP7 MC Unit is displayed. Transmit PDO mapping 1 to Transmit PDO mapping 4 are displayed. By default, Transmit PDO mapping 4 is selected.
Error code	Alarm (main number only)/warning information occurred in Servo Amplifier is received.
Status word	The state of Servo Amplifier is received.
Modes of operation display	The state of the control mode within Servo Amplifier is received.
Position actual value	Actual position information of motor is received.
Velocity actual value	Actual speed information of motor is received.
Torque actual value	Actual torque information of motor is received.
Touch probe status	The state of touch probe operation (Touch probe 1/Touch probe 2) is received. (Note)
Touch probe pos1 posvalue	Position information latched at leading edge of Touch probe 1 is received. (Note)
Digital inputs	The logic input state of external input signals is received.
Select The Outputs	The maps of data sent (output) by FP7 MC Unit and received by Servo Amplifier A6B/A5B are displayed. Receiving PDO mapping 1 to Receiving PDO mapping 4 is displayed. By default, Receiving PDO mapping 4 is selected.
Control word	Setting data of control instructions for Servo Amplifier such as PDS state transition is sent.
Modes of operation	Setting data of the control mode of Servo Amplifier is sent.
Target torque	Target torque value data in the torque profile mode (tq) and cyclic synchronous torque mode (cst) is sent.
Max torque	Setting data of the maximum torque of motor is sent.
Target position	Target position data of motor is sent.
Max motor speed	Maximum speed data of motor is sent.
Touch probe function	Basic setup data used for starting the touch probe operation (Touch probe 1/Touch probe 2) and various settings is set. (Note)
Target velocity	Target speed data of motor is sent.

(Note): It is not used in FP7 MC Unit.



### ◆ NOTES

- **For using FP7 MC Unit in combination with Servo Amplifier A6B/A5B, Transmit PDO mapping 4 and Receive PDO mapping 4 is used. Do not change the setting unless the general-purpose output (EXOUT1) is added. Careless changes of PDO mapping may cause malfunction.**

### 13.8.4 Change of PDO Mapping

For using the general-purpose output (EXOUT1) of Servo Amplifier, it should be added to the PDO mapping. The following procedure is explained on the condition that servo amplifiers have already been registered in CMI.



◆ PROCEDURE

1. Select an arbitrary servo amplifier in the project explorer.
2. Select PDO mapping in the device editor window.
3. Select "Settings" > "Enable Slave Edit" > "PDO Mapping" from the menu bar, and check the checkbox.

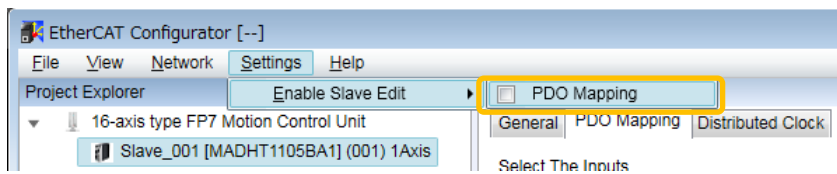

You can now edit the field of PDO map.

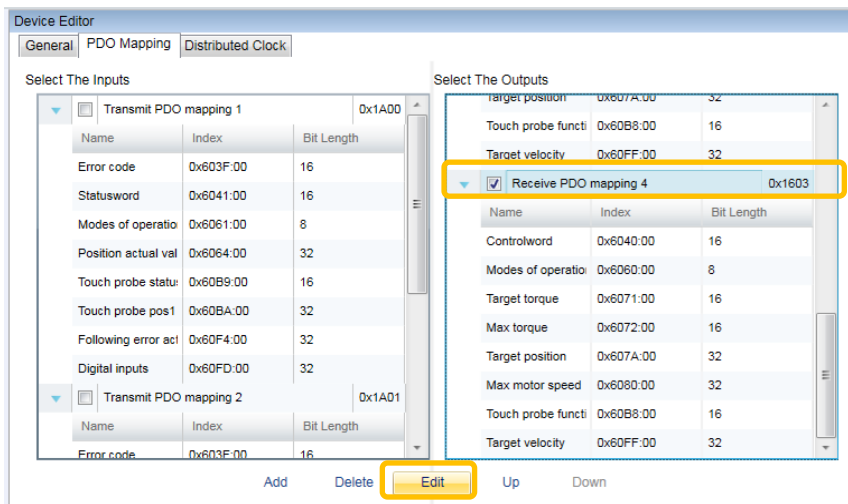

- Select "Receive PDO mapping 4" from the "Select The Outputs" box, and press the "Edit" button.

The "Edit PDO" dialog box is displayed.

- Press the [Add] button.

The "Add PDO" dialog box is displayed.

- Input the following items, and press the [OK] button.

It returns to the "Edit PDO" dialog box.

Item		Input content
General	Name	Digital Outputs
	Index	0x60FE
Settings	Sub index	1
	Data type	DINT

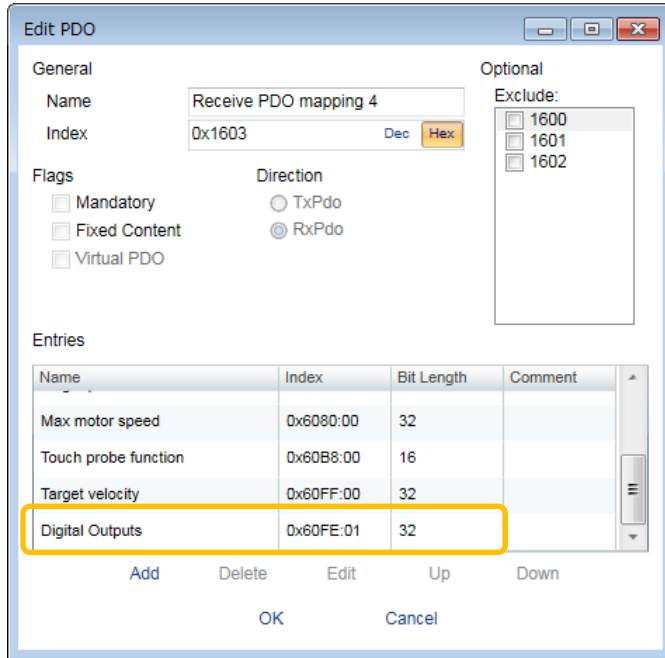

7. Confirm that the added information is displayed, and press the [OK] button.
8. Select "Settings" > "Enable Slave Edit" > "PDO Mapping" from the menu bar, and uncheck the checkbox.

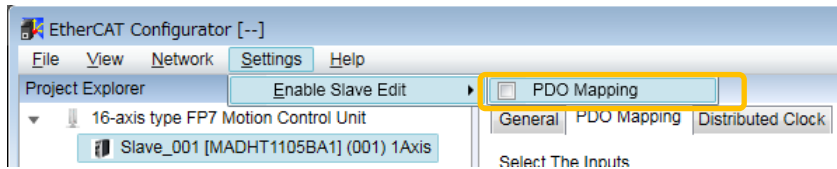

**NOTES**

- Carry out the operation of the above procedure 8 to prevent data from being rewritten carelessly after finishing the edit of PDO mapping.

# 13.9 SDO/PDO Communication

## 13.9.1 SDO Communication

FP7 MC Unit can perform SDO communication and PDO communication using CoE (CANopen over EtherCAT) protocol as a communication method with slave devices. SDO (Service Data Object) communication is a function to perform data communication with slave devices by user programs.

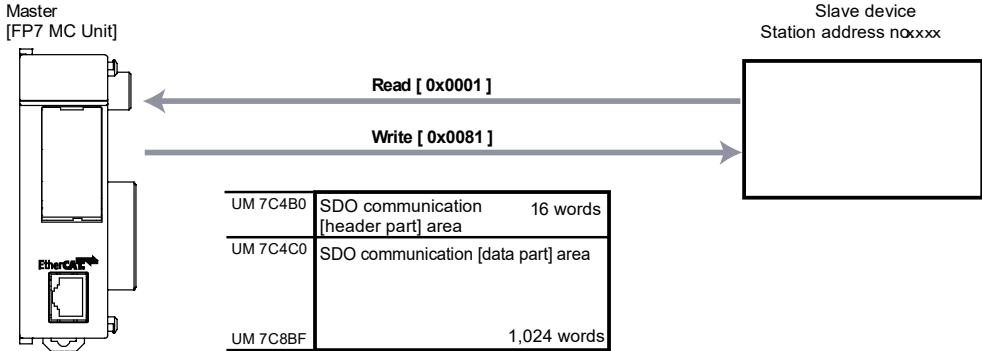

- Data sent/received is stored in the SDO communication area (data part) of the unit memory, and the communication is performed by controlling in the SDO communication area (header part).
- When communicating with slave devices by SDO communication, the data size that can be sent or received at a time is a maximum of 1,024 words (2,048 bytes).

■ Unit memories (SDO communication area)

●: Available, -: Not available

Axis no.	Unit memory no. (Hex)	Name	Default	Unit	Setting range and description	R	W
-	UM 7C4B0	Station Address	1	-	Station addresses of slave devices for SDO communication are set. Range: 1 to 192 When performing SDO communication with any setting values other than the above, an error (error code: 0001H) occurs. When specifying a node address that does not exist in the network, an error (error code: 0007H) occurs.	●	●
-	UM 7C4B1	Main-Index	0	-	The main index number of CoE object for SDO communication is set. Refer to CoE objects in respective manuals of slave devices.	●	●
-	UM 7C4B2	Sub-Index	0	-	The sub index number of CoE object for SDO communication is set. Refer to CoE objects in respective manuals of slave devices. When performing SDO communication with any setting values other than the above, an error (error code: 0002H) occurs.	●	●
-	UM 7C4B3	Data Type	0001H	-	The data type of CoE object for SDO communication is set. H1: Bool(1bit) H2: INT8(1byte) H3: INT16 (1word) H4: INT32 (2words) H5: UINT8(1byte) H6: UINT16 (1word) H7: UINT32 (2words) H8: - H9: STRING When performing SDO communication with any setting values other than the above, an error (error code: 0003H) occurs.	●	●



●: Available, -: Not available

Axis no.	Unit memory no. (Hex)	Name	Default	Unit	Setting range and description	R	W						
-	UM 7C4B4	Bit length	0	-	<p>When setting the data type to H9 (STRING) and performing SDO communication, the data unit (number of bytes) of CoE object data is set.</p> <table border="1"> <thead> <tr> <th>bit.</th> <th>Name</th> <th>Description</th> </tr> </thead> <tbody> <tr> <td>15-0</td> <td>Bit length</td> <td> <p>When reading: The number of bytes to be read from a slave device is set.</p> <p>When writing: The number of bytes to be written to a slave device is set.</p> <p>Setting range: 0x0000 to 0x03FF</p> </td> </tr> </tbody> </table>	bit.	Name	Description	15-0	Bit length	<p>When reading: The number of bytes to be read from a slave device is set.</p> <p>When writing: The number of bytes to be written to a slave device is set.</p> <p>Setting range: 0x0000 to 0x03FF</p>	●	●
bit.	Name	Description											
15-0	Bit length	<p>When reading: The number of bytes to be read from a slave device is set.</p> <p>When writing: The number of bytes to be written to a slave device is set.</p> <p>Setting range: 0x0000 to 0x03FF</p>											
-	UM 7C4B5	Command	0H	-	<p>Commands for SDO communication are set.</p> <table border="1"> <thead> <tr> <th>bit.</th> <th>Name</th> <th>Description</th> </tr> </thead> <tbody> <tr> <td>15-0</td> <td>Command</td> <td> <p>0000H: Initial state/processing done</p> <p>0001H: Read</p> <p>0081H: Write</p> <p>Any other settings will be errors.</p> </td> </tr> </tbody> </table>	bit.	Name	Description	15-0	Command	<p>0000H: Initial state/processing done</p> <p>0001H: Read</p> <p>0081H: Write</p> <p>Any other settings will be errors.</p>	●	●
bit.	Name	Description											
15-0	Command	<p>0000H: Initial state/processing done</p> <p>0001H: Read</p> <p>0081H: Write</p> <p>Any other settings will be errors.</p>											
-	UM 7C4B6	Result	0H	-	<p>SDO communication results are stored.</p> <table border="1"> <thead> <tr> <th>bit.</th> <th>Name</th> <th>Description</th> </tr> </thead> <tbody> <tr> <td>15-0</td> <td>Result</td> <td> <p>0000H: Normal end</p> <p>5555H: During processing (Waiting for response)</p> <p>FFFFH: Error occurs</p> <p>Any other settings will be errors.</p> </td> </tr> </tbody> </table>	bit.	Name	Description	15-0	Result	<p>0000H: Normal end</p> <p>5555H: During processing (Waiting for response)</p> <p>FFFFH: Error occurs</p> <p>Any other settings will be errors.</p>	●	-
bit.	Name	Description											
15-0	Result	<p>0000H: Normal end</p> <p>5555H: During processing (Waiting for response)</p> <p>FFFFH: Error occurs</p> <p>Any other settings will be errors.</p>											
-	UM 7C4B7	Timeout value	1H	0.1s	<p>The sending/receiving timeout monitor time (0.1 s) for SDO communication is set.</p> <p>Range: 1 to 2400 (0.1 s to 240 s)</p> <p>Any other settings will be errors.</p>	●	●						
-	UM 7C4B8 UM 7C4B9	Error code	0H	-	<p>The result of reading/writing processing (response code) is stored.</p>	●	-						

## Supplementary Functions

Error code	Name	Description
0000 0000H	Normal end	
0000 0001H	Station address setting value error	
0000 0002H	Sub index number setting value error	
0000 0003H	Data type setting value error	
0000 0005H	Command code setting value error	
0000 0006H	Timeout value setting value error	
0000 0007H	Station address setting value error	(It does not exist in network.)
0503 0000H	SDO abort code	Toggle bit not changed.
0504 0000H	SDO abort code	SDO protocol timeout.
0504 0001H	SDO abort code	Client/Server command specifier not valid or unknown.
0504 0005H	SDO abort code	Out of memory.
0601 0000H	SDO abort code	Not supported access to an object.
0601 0001H	SDO abort code	Attempt to read to a write only object.
0601 0002H	SDO abort code	Attempt to write to a read only object.
0601 0003H	SDO abort code	Sub index cannot be written, SIO must be 0 for write access.
0602 0000H	SDO abort code	The object does not exist in the object directory.
0604 0041H	SDO abort code	The object cannot be mapped into the PDO.
0604 0042H	SDO abort code	The number and length of the objects to be mapped would exceed the PDO length.
0604 0043H	SDO abort code	General parameter incompatibility reason.
0604 0047H	SDO abort code	General internal incompatibility in the device.
0606 0000H	SDO abort code	Access failed due to a hardware error.
0607 0010H	SDO abort code	Data type does not match, length of service parameter does not match.
0607 0012H	SDO abort code	Data type does not match, length of service parameter too high.
0607 0013H	SDO abort code	Data type does not match, length of service parameter too low.
0609 0011H	SDO abort code	Sub index does not exist.
0609 0030H	SDO abort code	Value range of parameter exceeded (only for write access).
0609 0031H	SDO abort code	Value of parameter written too high.
0609 0032H	SDO abort code	Value of parameter written too low.
0609 0036H	SDO abort code	Maximum value is less than minimum value.
0800 0000H	SDO abort code	General error.
0800 0020H	SDO abort code	Data cannot be transferred or stored the application.
0800 0021H	SDO abort code	Data cannot be transferred or stored to the application because of local control.
0800 0022H	SDO abort code	Data cannot be transferred or stored to the application because of the present device state.
0800 0023H	SDO abort code	Object dictionary dynamic generation fails or no object dictionary is present.

●: Available, -: No

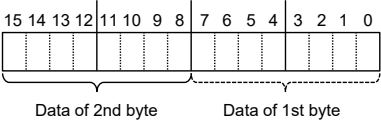
Axis no.	Unit memory no. (Hex)	Name	Default	Unit	Setting range and description	R	W
-	UM 7C4C0	Send/Receive data	0000H	-	When reading: Data read from slave devices and executed is stored. When writing: Data written to slave devices and executed is stored. The order of data storage is as follows. Example) 2-byte data 	●	●
-	UM 7C4C1		0000H	-		●	●
-	UM 7C4C2		0000H	-		●	●
-	UM 7C4C3		0000H	-		●	●
-	UM 7C4C4		0000H	-		●	●
-	UM 7C4C5		0000H	-		●	●
-	UM 7C4C6		0000H	-		●	●
-	UM 7C4C7		0000H	-		●	●
-	UM 7C4C8		0000H	-		●	●
-	UM 7C4C9		0000H	-		●	●
-	UM 7C4CA		0000H	-		●	●
-	UM 7C4CB		0000H	-		●	●
-	UM 7C4CC		0000H	-		●	●
-	UM 7C4CD		0000H	-		●	●
-	UM 7C4CE		0000H	-		●	●
-	UM 7C4CF		0000H	-		●	●
-	UM 7C4D0		0000H	-		●	●
-	UM 7C4D1		0000H	-		●	●
-	UM 7C4D2		0000H	-		●	●
-	UM 7C4D3		0000H	-		●	●
-	UM 7C4D4		0000H	-		●	●
-	UM 7C4D5		0000H	-		●	●
-	UM 7C4D6		0000H	-		●	●
-	UM 7C4D7		0000H	-		●	●
-	UM 7C4D8		0000H	-		●	●
-	UM 7C4D9		0000H	-		●	●
-	UM 7C4DA		0000H	-		●	●
-	UM 7C4DB		0000H	-		●	●
-	:		0000H	-		●	●
-	:		0000H	-		●	●
-	:		0000H	-		●	●
-	:		0000H	-		●	●

●: Available, -: Not available

Axis no.	Unit memory no. (Hex)	Name	Default	Unit	Setting range and description	R	W	
-	:	Send/Receive data	0000H	-	When reading: Data read from slave devices and executed is stored. When writing: Data written to slave devices and executed is stored. The order of data storage is as follows.	●	●	
-	:		0000H	-		Example) 2-byte data	●	●
-	:		0000H	-				●
-	:		0000H	-				●
-	UM 7C8A4		0000H	-	Example) 4-byte data	●	●	
-	UM 7C8A5		0000H	-			●	●
-	UM 7C8A6		0000H	-			●	●
-	UM 7C8A7		0000H	-			●	●
-	UM 7C8A8		0000H	-			●	●
-	UM 7C8A9		0000H	-			●	●
-	UM 7C8AA		0000H	-			●	●
-	UM 7C8AB		0000H	-			●	●
-	UM 7C8AC		0000H	-			●	●
-	UM 7C8AD		0000H	-			●	●
-	UM 7C8AE		0000H	-			●	●
-	UM 7C8AF		0000H	-			●	●
-	UM 7C8B0		0000H	-			●	●
-	UM 7C8B1		0000H	-			●	●
-	UM 7C8B2		0000H	-			●	●
-	UM 7C8B3		0000H	-			●	●
-	UM 7C8B4		0000H	-			●	●
-	UM 7C8B5		0000H	-			●	●
-	UM 7C8B6		0000H	-			●	●
-	UM 7C8B7		0000H	-			●	●
-	UM 7C8B8		0000H	-			●	●
-	UM 7C8B9		0000H	-			●	●
-	UM 7C8BA		0000H	-			●	●
-	UM 7C8BB		0000H	-			●	●
-	UM 7C8BC		0000H	-			●	●
-	UM 7C8BD		0000H	-			●	●
-	UM 7C8BE		0000H	-			●	●
-	UM 7C8BF		0000H	-			●	●

■ SDO communication Read (receive) method

The following flowchart shows the flow of the operation required in a user program for the SDO communication reading process.

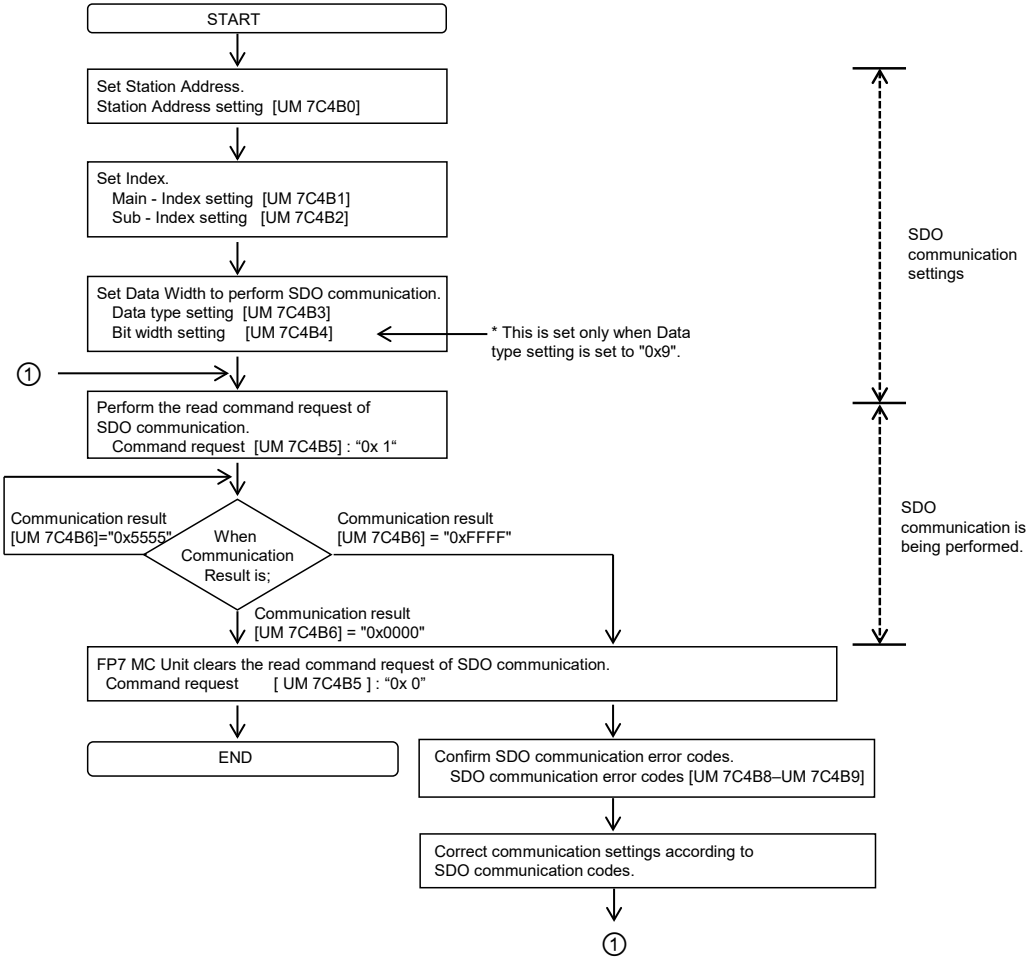

Example) When performing the reading process for Index: 0x1018 Sub-Index: 0x01 Data type: U32 [Value: 0x0000066F]

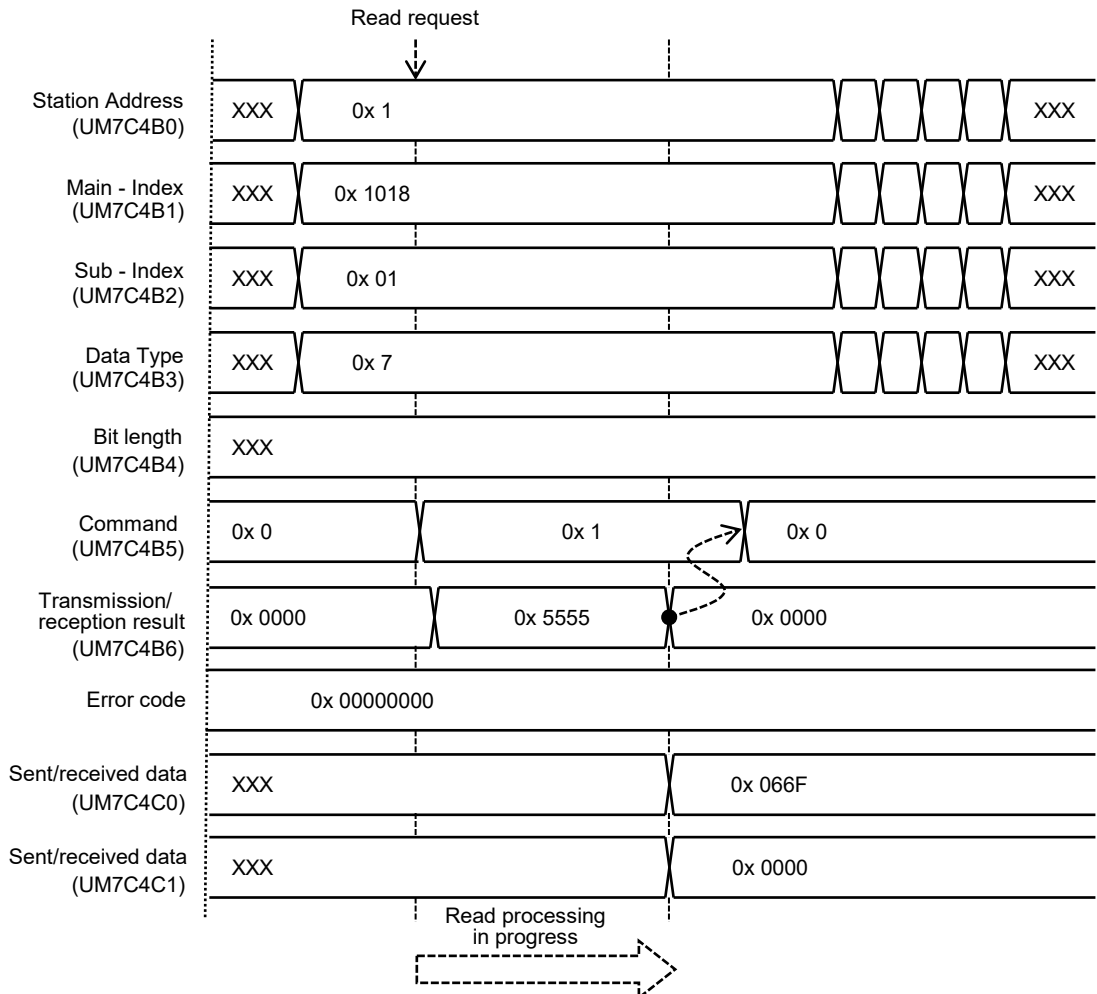

■ Sample program (SDO communication: Read)

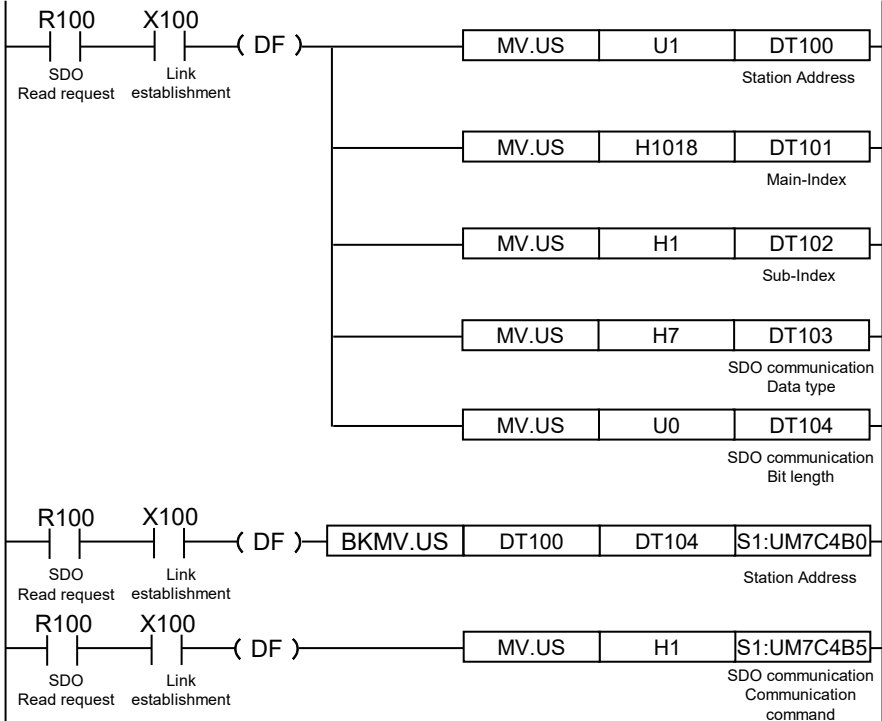

■ SDO communication Write (send) method

The following flowchart shows the flow of the operation required in a user program for the SDO communication writing process.

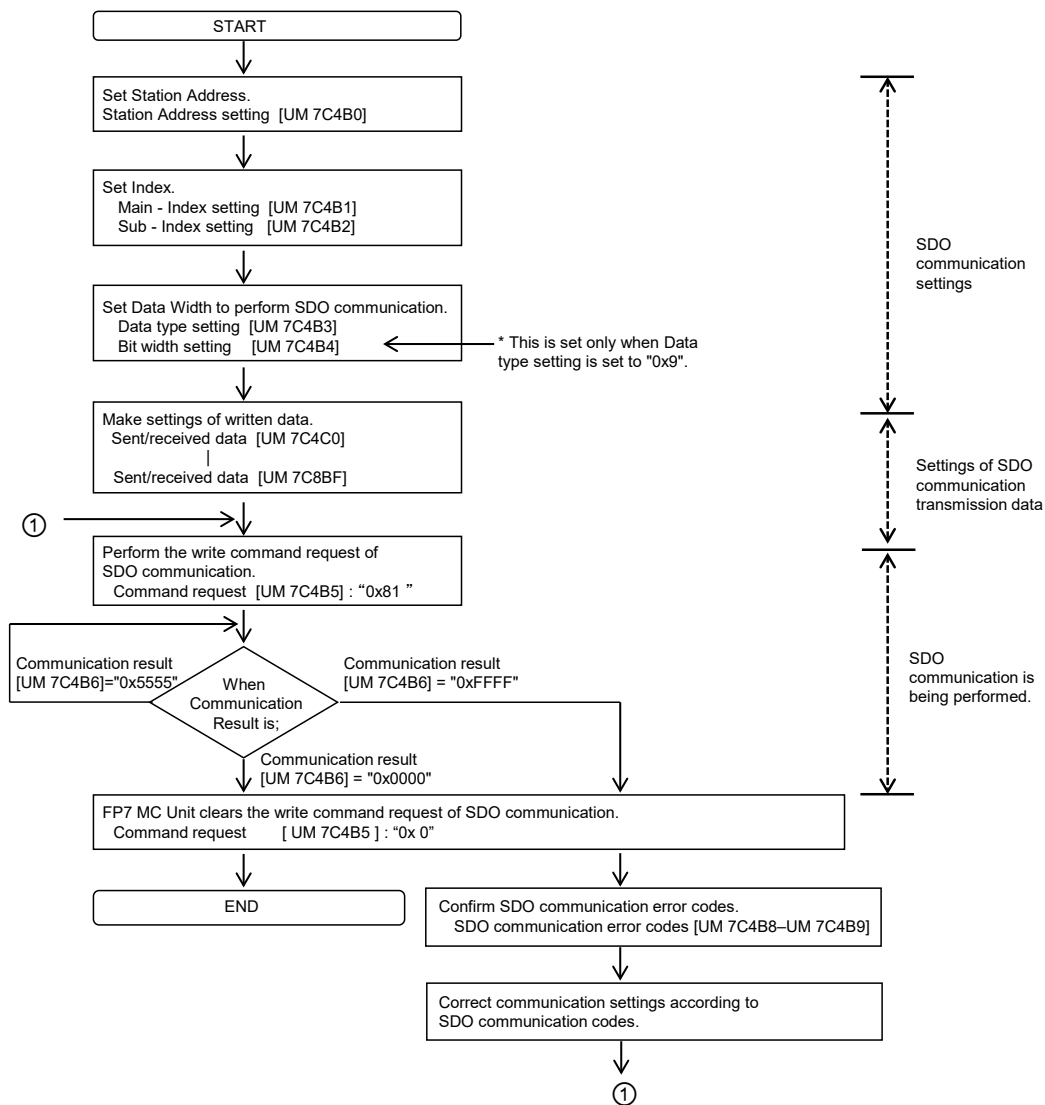



Example) When performing the writing process for Index: 0x3214 Sub-Index: 0x00 Data type:16 [Value:200]

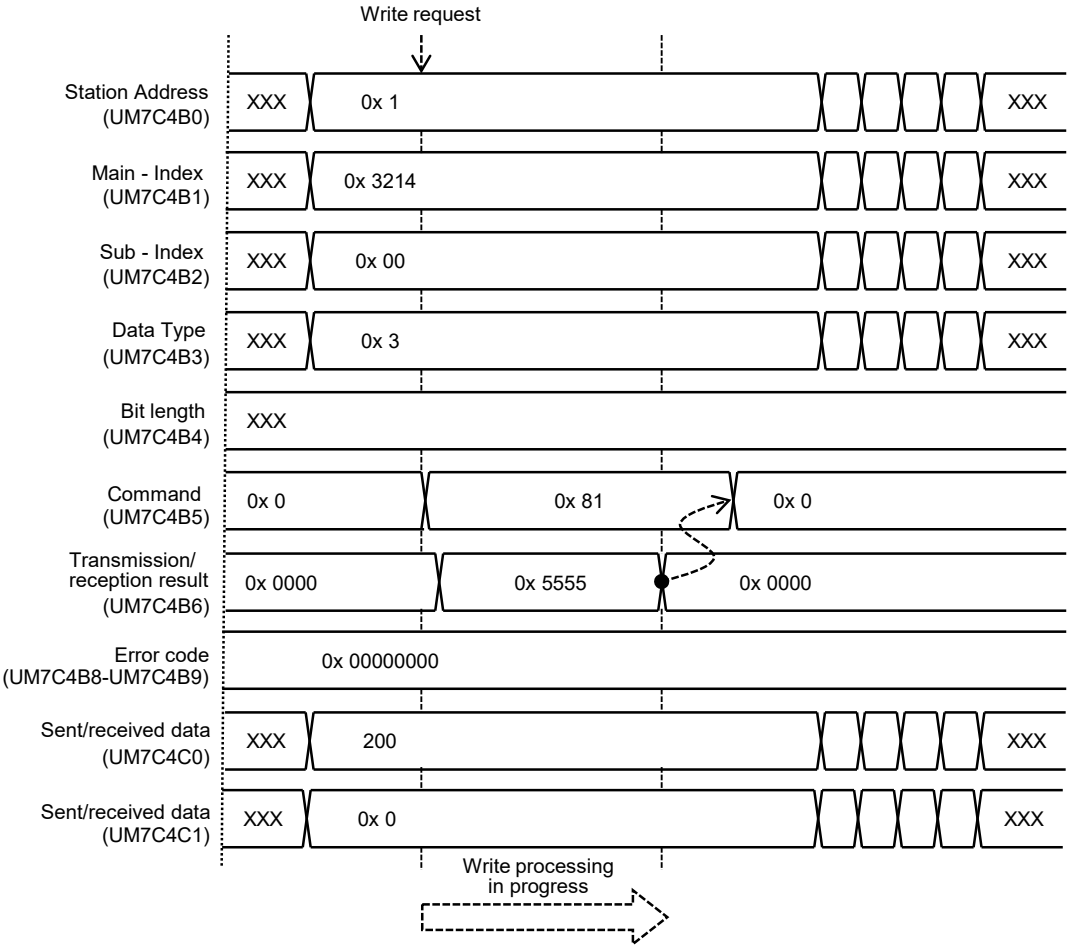

■ Sample program (SDO communication: Write)

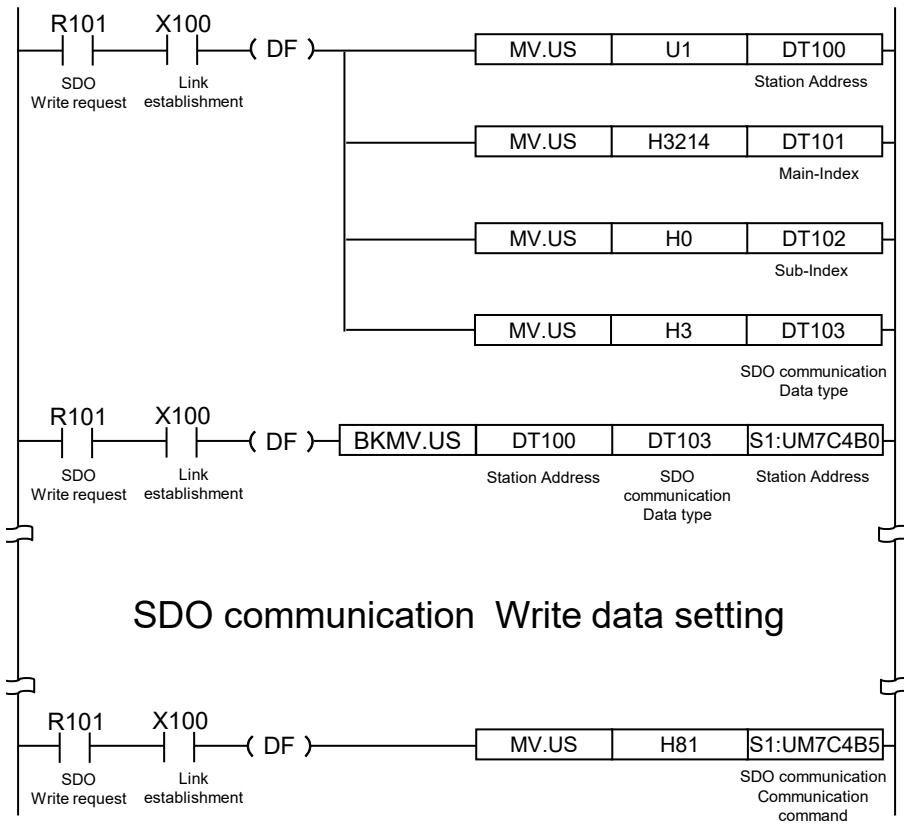

### 13.9.1.1 Multi-turn Data Clear

- By using SDO communication, you can clear multi-turn data for servo amplifier MINIAS A6B/A5B via FP7MC Unit.
- You can clear multi-turn data by using servo amplifier CoE object "4D00H[Main-Index(Special function)]\_01H[Sub-Index(Special function start flag1)]" and "4D01H(Main-Index)\_00H[Sub-Index(Special function setting9)]".  
For the detailed procedure and precautions, refer to "b) Clearing multi-turn data" in "4) Initializing the absolute encoder (during semi-closed control)" in "6-9-4 Position Information" in the Servo Amplifier Specification (A5B: SX-DSV02470, A6B: SX-DSV03216).

#### Contents of sample program

Mark	Description
①	Set "SDO communication Station Address"
②	Write 0031H to CoE object "4D01H_00H" (SDO communication Write)
	Ⓐ Write request: ON
	Ⓑ Set "SDO communication Main-Index (4D01H), Sub-Index (00H), Data type (UINT16), write data (0031H), command (Write)"
	Ⓒ SDO communication completion check
	Ⓓ Normal/abnormal termination check for SDO communication completion (result)
③	Change bit 9 of CoE object "4D00H_01H" from 0 to 1 (SDO communication Write)
	Ⓐ Write request: ON
	Ⓑ "SDO communication Main-Index (4D00H), Sub-Index (01H), Data type (UINT32), write data (0200H), command (Write)"
	Ⓒ SDO communication completion check
	Ⓓ Normal/abnormal termination check for SDO communication completion (result)
④	Check that CoE object "4D01H_00H" is set to 0000H (SDO communication Read)
	Ⓐ Read request: ON
	Ⓑ Set "SDO communication Main-Index (4D01H), Sub-Index (00H), Data type (UINT16), command (Read)"
	Ⓒ SDO communication completion check
	Ⓓ Normal/abnormal termination check for SDO communication completion (result)
	Ⓔ Normal/abnormal termination check for SDO communication completion (read data)
⑤	Change bit 9 of CoE object "4D00H_01H" from 1 to 0 (SDO communication Write)
	Ⓐ Write request: ON
	Ⓑ Set "SDO communication Main-Index (4D00H), Sub-Index (01H), Data type (UINT32), write data (0000H), command (Write)"
	Ⓒ SDO communication completion check
	Ⓓ Normal/abnormal termination check for SDO communication completion (result)

Sample program

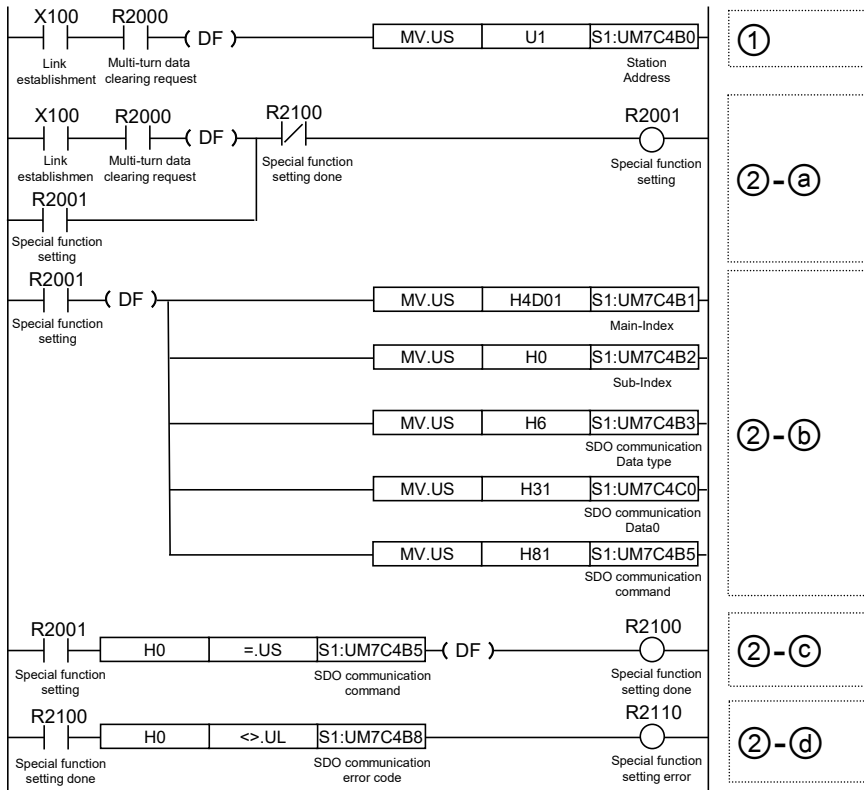

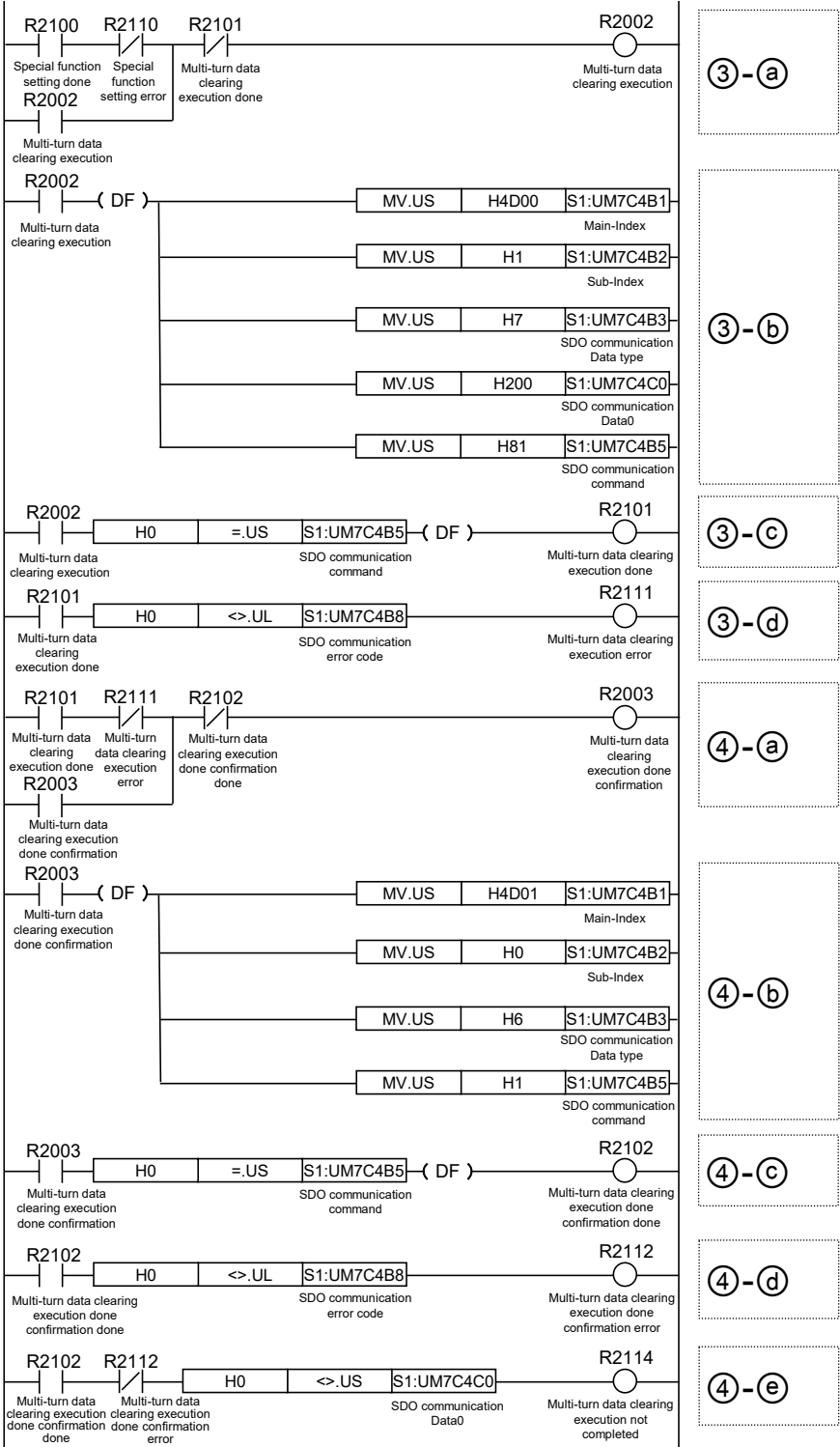

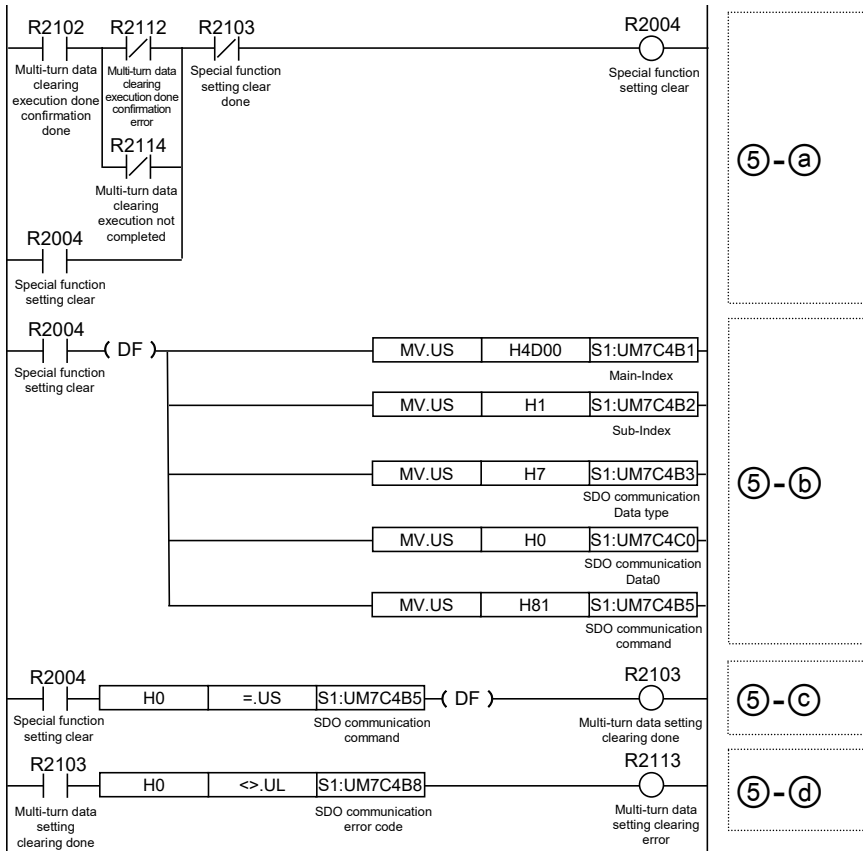

### 13.9.1.2 Saving Servo Amplifier Parameters

- By using SDO communication, you can save parameters for servo amplifier MINIAS A6B/A5B via FP7MC Unit.
- By writing "save (73617665H)" to servo amplifier CoE object "1010H[Main-Index(Store parameters)]\_01H[Sub-Index(Save all parameters)]", you can save all backup target objects of the servo amplifier into the EEPROM of the servo amplifier.  
For details on backup target objects, refer to "5-6 Store Parameters (for Writing Objects to EEPROM) in the Servo Amplifier Specification (A5B: SX-DSV02470, A6B: SX-DSV03216).

#### Contents of sample program

Mark	Description
①	Write "save (73617665H)" to CoE object "1010H_01H" (SDO communication Write)
	Ⓐ Set "SDO communication Main-Index (1010H), Sub-Index (01H), Data type (UINT32), write data ("save"), command (Write)"
	Ⓑ Write request: ON
	Ⓒ Set "SDO communication command (Write)"
	Ⓓ SDO communication completion check
	Ⓔ Normal/abnormal termination check for SDO communication completion (result)
②	Check that CoE object "1010H_01H" is set to 0001H (SDO communication Read)
	Ⓐ Read request: ON
	Ⓑ Set "SDO communication command (Read)"
	Ⓒ SDO communication completion check
	Ⓓ Normal/abnormal termination check for SDO communication completion (result)
	Ⓔ Normal/abnormal termination check for SDO communication completion (read data)

Sample program

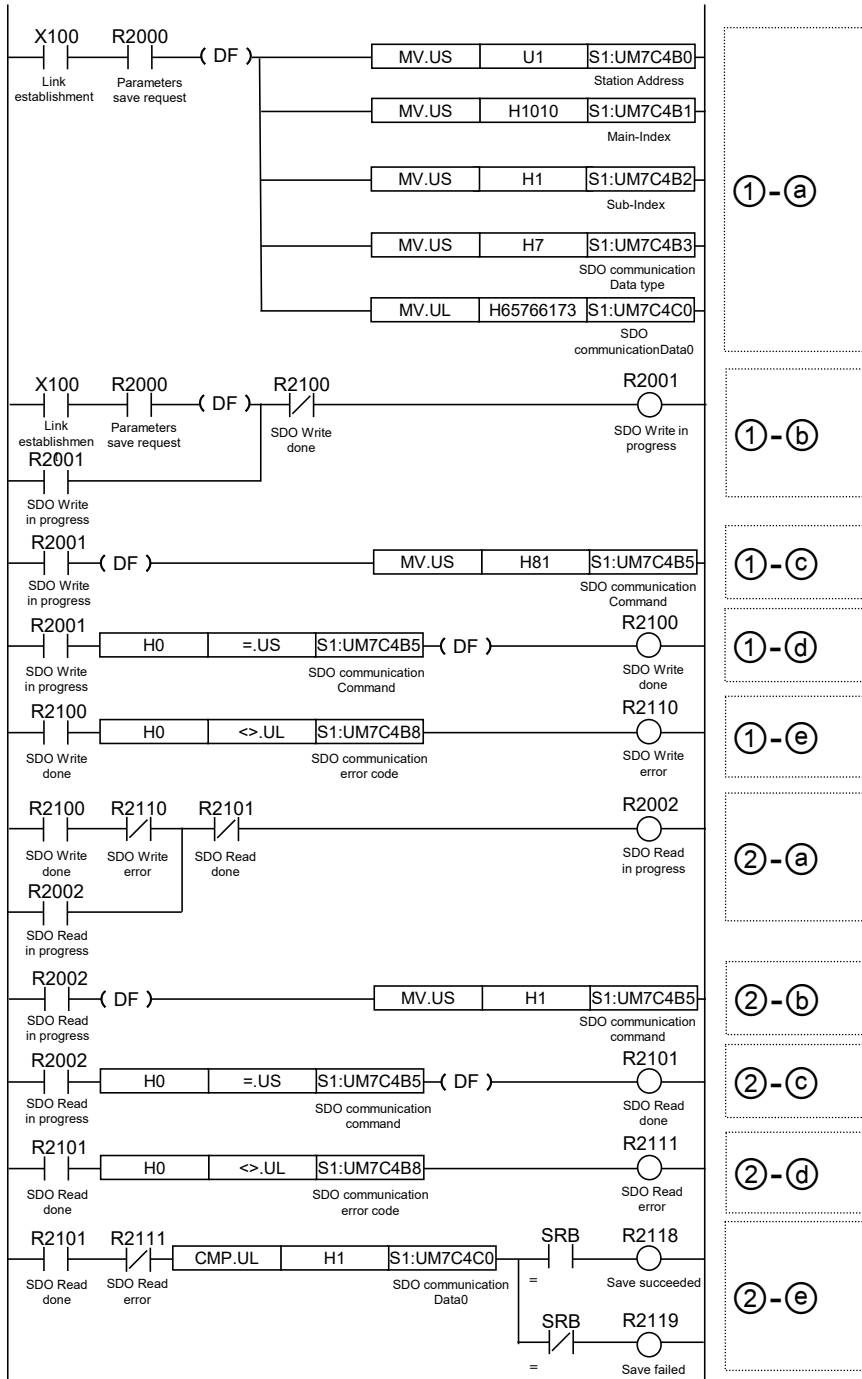



### 13.9.2 PDO Communication

- FP7 MC Unit can perform SDO communication and PDO communication using CoE (CANopen over EtherCAT) protocol as a communication method with slave devices.
- PDO (Process Data Object) communication is a function to perform the communication between a master (FP7 MC Unit) and slave devices for each EtherCAT communication cycle. However, CoE objects (objects allocated to Receive PDO mapping) used for the motion control operation in FP7 MC Unit cannot be used.
- Objects allocated to Transmit PDO mapping can be monitored in the TxPDO communication area.

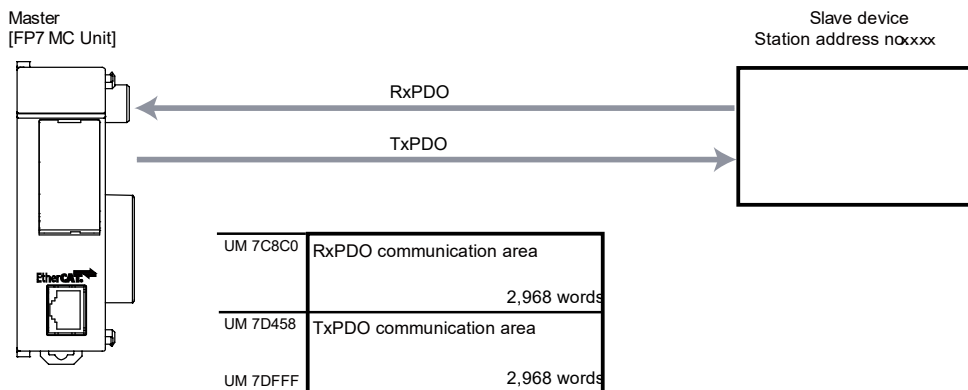

#### ■ Unit memory addresses for PDO communication

Data can be sent and received by user programs in accordance with the PDO mapping set in "13.8 EtherCAT Communication Setting". The addresses of the unit memories used for PDO communication can be confirmed in the "Variables" tab in the "Device Editor" window of EtherCAT Configurator.

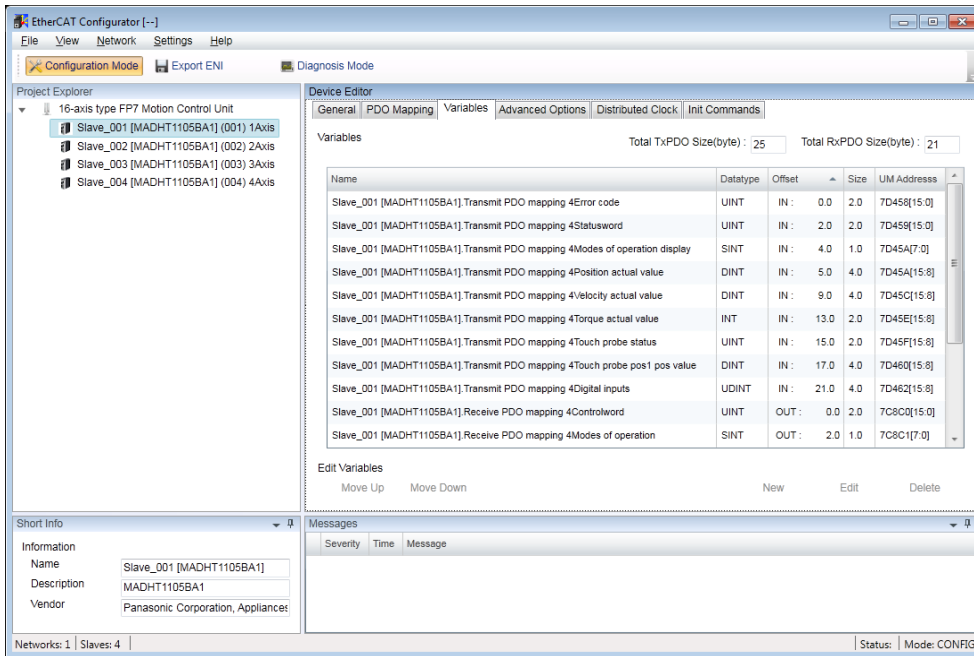

## ■ Precautions on programming

- PDO communication can be used only when ESM is "SafeOP" or "OP". In addition, when it is "SafeOP", only "Slave->Master (TxPDO communication)" can be used.
- PDO communication cannot be used in the diagnosis mode.

## 13.10 ESI Manager

ESI files of slaves connected to FP7 MC Unit need to be registered by the ESI manager in the EtherCAT communication menu "EtherCAT Configurator" of CMI. The following procedure is explained on the condition that CMI has already started.



### ◆ PROCEDURE

1. Select "File" > "ESI Manager" from the menu bar.

The "ESI Manager" window is displayed.

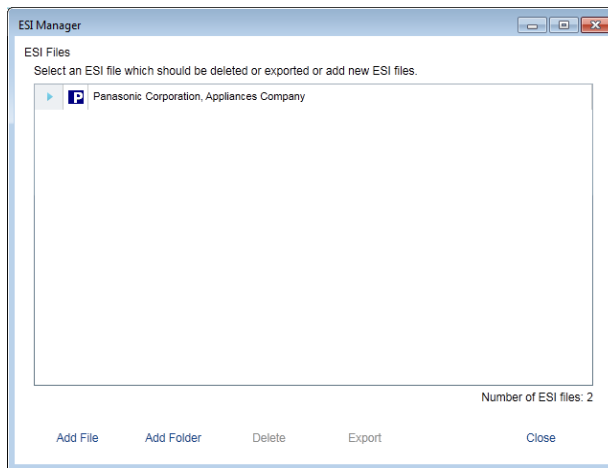

2. Press the [Add File] button.

The "Add ESI File" dialog box is displayed.

3. Select an arbitrary ESI file (.xml) and press the [Open] button.

The ESI file is added and the slave device can be registered in the EtherCAT communication setting menu "EtherCAT Configurator" of CMI.

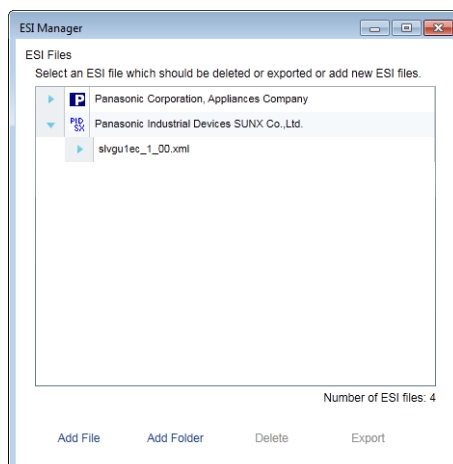

4. Press the [Close] button.

## 13.11 Connection with Slave SL-VGU1-EC

### 13.11.1 Registration of Slaves

Slaves connected to FP7 MC Unit are registered using the EtherCAT communication setting menu “EtherCAT Configurator” of CMI. The following procedure is explained on the condition that CMI has already started.



#### ◆ PROCEDURE

1. Select “Parameter” > “EtherCAT communication settings” from the menu bar.

The “EtherCAT Configurator” window is displayed.

2. Right-click on “FP7 Motion Control Unit” in the project explorer.

The context menu is displayed.

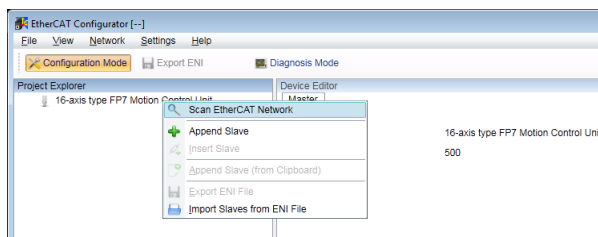

3. Select “Append Slave” from the context menu.

The dialog box for selecting slaves is displayed.

4. Select slaves to be used from the list.

5. Input the number of slaves, and press the [OK] button.

The registration state of the slaves connected to FP7 MC Unit is displayed in the project explorer. The list shows the slaves in the connection order from the unit connected to FP7 MC Unit first.

## 13.11.2 Confirmation of Unit Memory Numbers

Unit memory numbers for accessing SL-VGU1-EC from FP7 MC Unit can be confirmed in the "Variables" tab on the "Device Editor" window. They can be updated periodically by PDO communication and can be read via unit memories by user programs.

The screenshot shows the EtherCAT Configurator interface. The 'Device Editor' window is open to the 'Variables' tab. A table lists the following variables:

Name	Datatype	Offset	Size	UM Address
Slave_002 [SL-VGU1-EC].IN 0-31 Bit TxPDOIN 0	BOOL	IN : 25.0	0.1	7D464[8]
Slave_002 [SL-VGU1-EC].IN 0-31 Bit TxPDOIN 1	BOOL	IN : 25.1	0.1	7D464[9]
Slave_002 [SL-VGU1-EC].IN 0-31 Bit TxPDOIN 2	BOOL	IN : 25.2	0.1	7D464[10]
Slave_002 [SL-VGU1-EC].IN 0-31 Bit TxPDOIN 3	BOOL	IN : 25.3	0.1	7D464[11]
Slave_002 [SL-VGU1-EC].IN 0-31 Bit TxPDOIN 4	BOOL	IN : 25.4	0.1	7D464[12]
Slave_002 [SL-VGU1-EC].IN 0-31 Bit TxPDOIN 5	BOOL	IN : 25.5	0.1	7D464[13]
Slave_002 [SL-VGU1-EC].IN 0-31 Bit TxPDOIN 6	BOOL	IN : 25.6	0.1	7D464[14]
Slave_002 [SL-VGU1-EC].IN 0-31 Bit TxPDOIN 7	BOOL	IN : 25.7	0.1	7D464[15]
Slave_002 [SL-VGU1-EC].IN 0-31 Bit TxPDOIN 8	BOOL	IN : 26.0	0.1	7D465[0]

Example of SL-VGU1-EC allocation



### ◆ KEY POINTS

- When the data type is Boolean type (bit device), bit numbers are displayed in [ ] for corresponding "UM Addresses".  
Example: 7D464[8] -> It indicates the bit number 8 of UM7D464.

## 13.12 Connection with Slave Encoder Input Device

### 13.12.1 Operation of Encoder Input Device

- The encoder input device operates as a ring counter.
- The count range of a usable encoder input device is unsigned 32 bits (0 to 4,294,967,295 [H FFFF FFFF]).

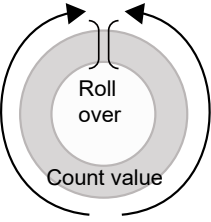
Item	Specifications
Operation image	<div style="text-align: center;"> <p>4,294,967,295 [H FFFF FFFF]      0</p>  <p>Count up      Count down</p> </div>
Operation when reaching the upper limit or lower limit	<p>If the count value exceeds "4,294,967,295", the count value will be "0" automatically and the count operation will continue. If the count value falls below "0", the count value will return to "4,294,967,295" automatically and the count operation will continue.</p>



#### ◆ REFERENCE

- For details of the specifications and setting method of encoder, refer to the specification sheet and manual of the encoder. Encoder that operation check has done: GX-EC0211 [Encoder input terminal] made by OMRON Corporation

## 13.12.2 Configuration

For connecting an encoder input device to the network, it should be allocated to use axes in CMI.



### ◆ PROCEDURE

1. Register the number of counters of the encoder input device in the axis change setting.

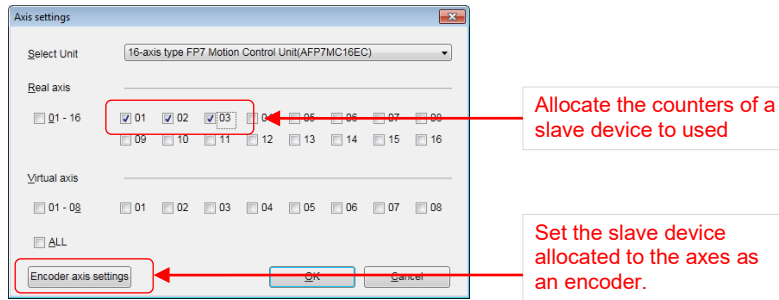

After that, press the [Encoder axis settings] button and set the registered axes are encoder axes.

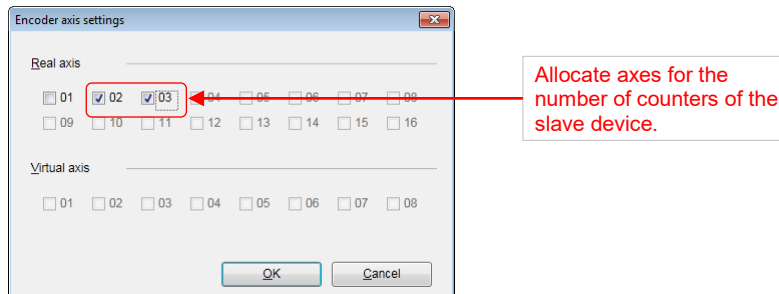

\* (asterisk) is displayed for the axes set as encoder axes.

2. Register the encoder input device as a slave. (Refer to 4.4 Setting of Network Configuration.)

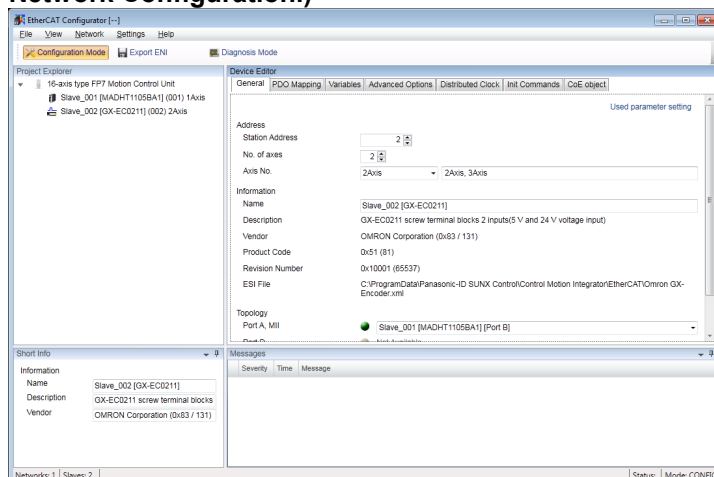

3. Set the number of counters of the encoder input device.

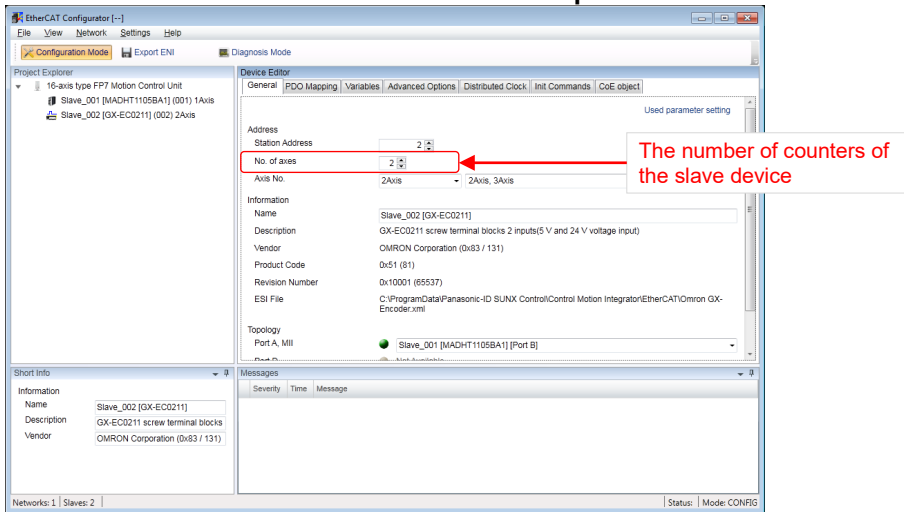

4. Set to monitor the number of counters of the encoder input device by "AMP current value" in "Each axis information & monitor area" of FP7 MC Unit. Click "Used parameter setting".

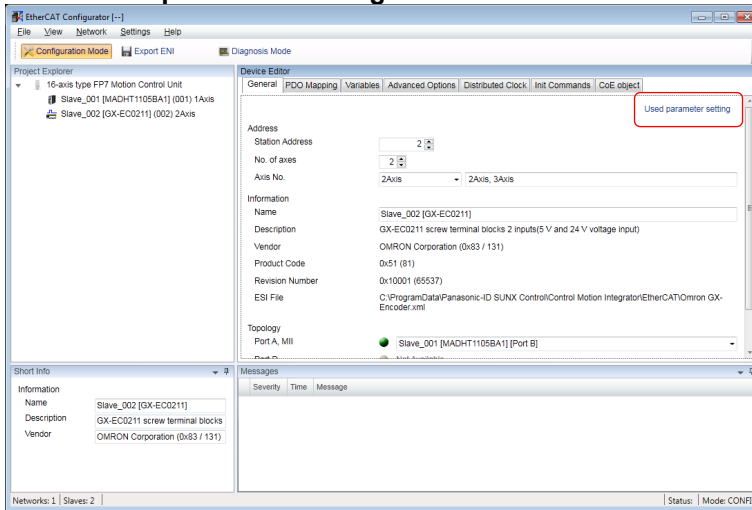



- The "Used parameter setting" window is displayed. Set an index number for the CoE object of the target slave device in "Position actual value (actual position information area of motor)".

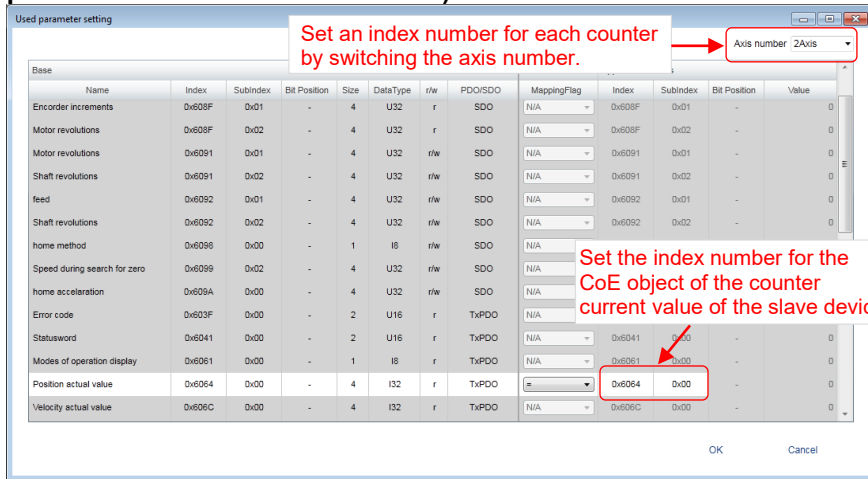

### 13.12.3 Monitor Operation

The input from the encoder can be counted. After that, it can be monitored by the AM current value by requesting to turn on the servo of the axes for the encoder registered in FP7 MC Unit.

●: Available, -: Not available

Axis no.	Unit memory no. (Hex)	Name	Default	Description	R	W
1	UM 02654 -UM 02655	AMP current value (Absolute coordinate)	K0	Stores the current value based on a mechanical origin in pulse units. It will be reset to "0" on the completion of home return. The value will not be updated when the current value update function is executed. Unit: pulse	●	-
1	UM 02656 -UM 02657	Current value after unit conversion (Logic system coordinate)	K0	Stores the current value based on an electric origin (value set as home position coordinate). Stores values converted with the unit system (pulse, μm, inch, degree) selected in the axis parameter as integer. When the home return is completed, the value set as home position coordinate will be stored. When "0" is set as home position coordinate, it will be reset to "0". This area is also updated when the current value update function is used.	●	-

(Note): The count range of encoder input is unsigned 32 bits (0 to 4,294,967,295).

## 13.13 EC Packet Monitor Function

---

### 13.13.1 Overview of Function

---

The packet monitor function is a function to store sent or received packet data between the master (FP7 MC Unit) and slaves (Servo Amplifier A6B/A5B) as files. Packet data can be confirmed using commercial analyzer software. An SD memory card is required for using the EC packet monitor function.

#### ■ Specifications of FP7 MC Unit

Item	Description
Storage destination	SD memory card inserted in FP7 MC Unit
Packet data file format	TCP Dump format (cap)
Packet data file size	Max. 6 Mbytes per file
No. of packets	Max. 3904 packets
Storage timing	<p>The following two types of storage timing are available. It is set in "MC common settings" of CMI.</p> <ol style="list-style-type: none"> <li>1. After the power turns on, EC packet is stored after FP7 MC Unit turns on the initialization done (XF).</li> <li>2. EC packet is stored by turning on the EC packet monitor request (Y1) at an arbitrary timing by a user program.</li> </ol>

### 13.13.2 Stored Files

---

Packet data files are stored in a format such as the following in SD memory cards.

#### ■ Specifications of FP7 MC Unit

Item	Description
Storage destination folder	\\ECpacketLog
Stored file	<p>File name: yyyyMMddhhmm-***</p> <p>yyyy: Year, MM: Month, hh: Hour, mm: Minute, ***: Generation (000-999)</p>

### 13.13.3 Handling of SD Memory Card

#### ■ Usable SD memory cards

Use of Panasonic industrial SD memory cards (SLC type) is recommended.

[https://panasonic.net/cns/sdcard/industrial\\_sd/index.html](https://panasonic.net/cns/sdcard/industrial_sd/index.html)

(Note) An operation check has not been conducted for SD memory cards made by other manufacturers.

Printed logo on CPU unit	Usable SD memory cards	
	Card type	Capacity
	SDHC memory card	512MB to 16GB

#### ■ Cautions on handling an SD memory card

The data saved in the SD memory card may be lost in the following cases. We assume no responsibility whatsoever for the loss of saved data.

- The user or a third party has misused the SD memory card.
- When the SD memory card was affected by any static electricity or electrical noise.
- The SD memory card was taken out, or the PLC body was powered off, while the card was being accessed.

#### ■ Formatting an SD memory card

In principle, SD memory cards have been formatted by the time of purchase, and no formatting by the user is required. If formatting becomes necessary, download formatting software for SD memory cards on the following website.

"SD Association's website"

<https://www.sdcard.org/home/>



#### ◆ NOTES

- **A file system formatted by PC's standard formatting software does not satisfy the SD memory card specifications. Please use the dedicated formatting software.**
- **It is recommended to save important data in another media for backup. Never remove the card or power off the PLC body while the SD LED on FP7 MC Unit is lit (data is being read from or written into the card). Data may be damaged.**
- **Do not use an SD memory card the memory capacity of which is more than the usable capacity. Data in the card may be damaged.**

### 13.13.4 How to Set

For using the packet monitor function, the settings related to the EC packet monitor are configured in CMI.

#### ■ MC common settings dialog box

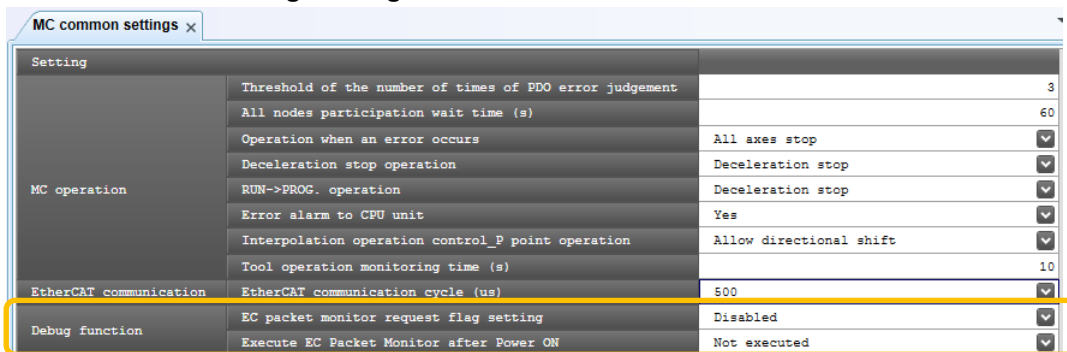

Item	Default	Description
EC packet monitor request flag setting	Disabled	Set the operation of packet monitor request flag of EC (EtherCAT) communication. Disabled Packet monitor is not executed when EC packet monitor request flag turns on. Enabled Packet monitor is executed when EC packet monitor request flag turns on.
Execute EC Packet Monitor after Power ON	Not executed	Set whether or not to execute the EC packet monitor after the power is turned on. Not executed / Executed

#### ■ Executing by user programs

For executing the packet monitor, turn on the EC packet monitor request (Y1) at an arbitrary timing.

I/O allocation	Target axis	Name	Description
X1	All axes	EC packet monitor active	Turns on when the monitoring of EtherCAT communication packet is executed by the EC packet monitor request (Y1). ON: Monitoring is executed, OFF: Monitoring stops
Y1	All axes	EC packet monitor request	Requests the start of the monitor of EtherCAT communication packet when the EC packet monitor request flag is enabled by "MC common parameter". The packet data is saved in an SD memory card. The monitoring stops when (Y1) turns off. The monitoring also stops, and (X1) turns off when the packet monitor capacity reaches 6 Mbytes or 3904 packets.

---

### 13.13.5 How to Execute

---

The packet monitor is executed in the following procedure.

	Procedure
①	Insert the SD memory card into FP7 MC Unit.
②	Confirm that the EC packet monitor is set with CMI.
③	Turn on the power supply.
④	Confirm that the operation monitor LED [SD] is off, and remove the SD memory card.

## 13.14 How to Delay EtherCAT Communication Startup after Power ON

By using the EtherCAT communication stop request signal (YA) of FP7 MC Unit, you can delay EtherCAT communication startup after the PLC is turned ON.

The delay time can be controlled by setting the time period during which the EtherCAT communication stop request signal (YA) remains in ON state after the PLC is turned ON.

(Note): This function is supported by FP7 MC Unit Ver. 1.5 and later.

### Sample program

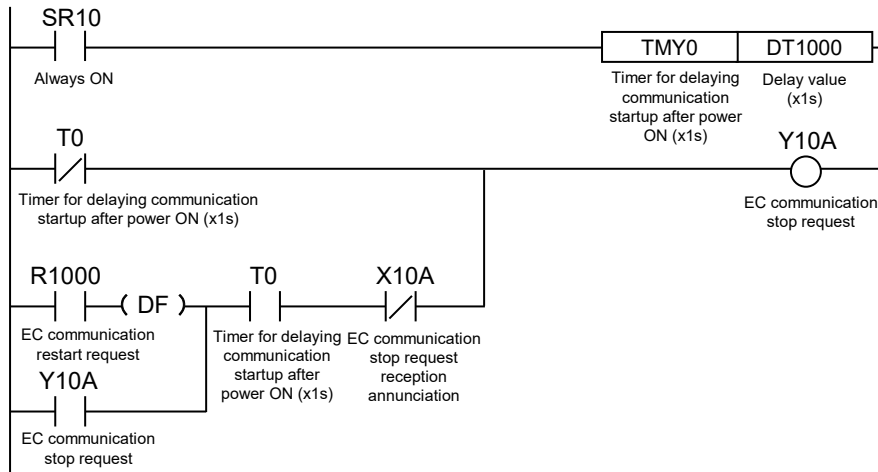

**14**

**CMTimeChart Monitor**

# 14.1 Overview of Function

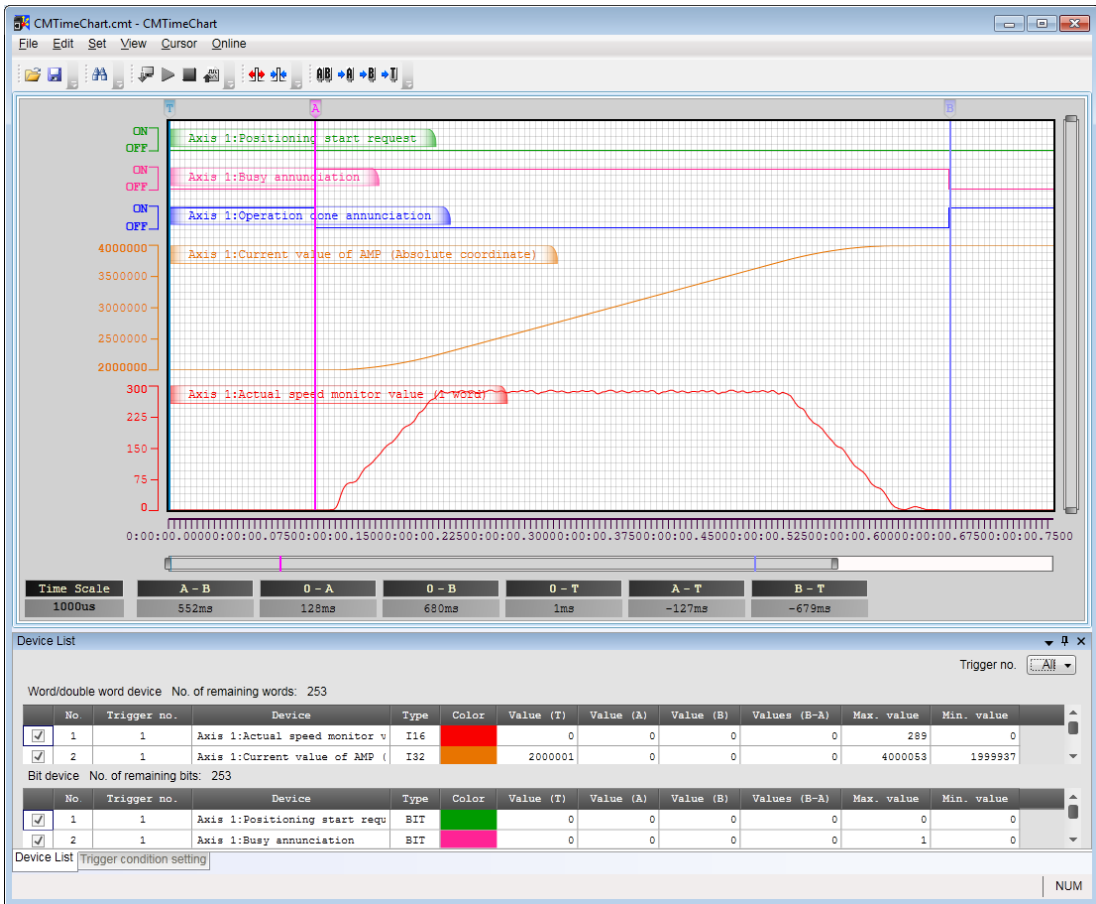



### ■ Function of CMTimeChart

- This is a function to display data logged in the memory of FP7 MC Unit as time chart by reading it.
- Up to 256 monitored devices can be registered. Also, up to 16 trigger conditions can be set as triggers to start logging data.
- Logging data can be executed by setting the logging condition and downloading it to the unit.

### ■ Execution procedure of CMTimeChart

	Item	Description	Reference
①	Start CMTimeChart.	CMTimeChart can be started from the menu of CMI.	
②	Register devices.	Set devices to be logged. (Max. 256 devices) Word devices and bit devices in the unit memories can be specified for devices to be logged.	p.14-4
③	Set trigger conditions.	Specify conditions used as triggers for logging (Max. 16 conditions). Leading edges and trailing edges of bit devices or values of word devices can be set as comparison conditions.	p.14-6
④	Download setting data for CMTimeChart.	Download set conditions (registered devices and trigger conditions).	p.14-12
⑤	Start and stop the logging operation.	Start and stop the logging operation by the CMTimeChart operation or user programs. The logging situation can be confirmed in the monitor of CMTimeChart or unit memories.	p.14-13
⑥	Upload logging data.	When the logging operation is complete and log data is stored in FP7 MC Unit, data can be uploaded. When uploading logging data, it can be confirmed as a time chart.	p.14-20

### ■ Starting CMTimeChart

CMTimeChart can be started from the menu of CMI.  
Select "Online" > "Time Chart" from the menu bar.

## 14.2 Registration of Devices

---

Devices on which logging is performed are registered in the device list of "CMTimeChart". The following procedure is explained on the condition that "CMTimeChart" has already started on CMI.



### ◆ PROCEDURE

---

1. Select "Set" > "Register Device" from the menu bar. Or double-click an arbitrary line in the device list window.

The "Register Device" dialog box is displayed.

2. Select Trigger number, Object, Classification, Device, Axis number, Device type, Used bit position and Color.
3. Press the [OK] button.

The information on the registered device is displayed in the device list.

### ■ Setting items (When Object is MC Unit)

Item	Description
Trigger no.	Select a trigger number corresponding to the monitored device. Range: 1 to 16
Object	MC Unit
Classification	Select one from eleven classification items of unit memory configuration. All / Input control area / Output control area / Each axis information & monitor area / IO area / Operation speed rate setting area / Torque limit area / Error annunciation & clear area / Warning annunciation & clear area / Synchronous control monitor area / Each axis setting parameter area
Device	Select a device available for the item selected in Classification.
Axis number	Select a target axis number.
Device Type	When a device and axis number is selected, these items will be automatically set. When one bit in a word device is specified, the used bit position is displayed.
Used bit position	
Color	Select a display color on the time chart monitor. Double-clicking it will open the "Color" editor.

### ■ Setting items (When Object is Slave)

Item	Description
Trigger no.	Select a trigger number corresponding to the monitored device. Range: 1 to 16
Object	Slave
Node address	Set the station address (node number) of the slave device.
Main Index	Set the index, sub index and data type of the slave.
Sub Index	
Device Type	
Used bit position	When specifying "Bit device" in the word device, set the used bit position.
Color	Select a display color on the time chart monitor. Double-clicking it will open the "Color" editor.



#### ◆ KEY POINTS

- The device displayed on the time chart is specified along with trigger conditions (1 to 16).
- Switching the object between "MC Unit" and "Slave" in the "Register Device" dialog box switches the selectable items.

## 14.3 Trigger Condition Setting

---

### 14.3.1 Setting Procedure of Trigger Conditions

---

Trigger conditions are registered in the trigger condition setting of CMTimeChart. The following procedure is explained on the condition that "CMTimeChart" has already started on CMI.



#### ◆ PROCEDURE

---

1. Select "View" > "Trigger condition setting" from the menu bar. Or click Trigger window

The Trigger condition setting dialog box is displayed.

Trigger no.	1
Sampling	
Communication cycle (ms)	0.5
Communication cycle magnification	1
Sampling cycle (ms)	0.5
Measurement time (ms)	4
No. of sampling data	8
Trigger mode	Single
Trigger position	0
Trigger condition	A
Trigger A	<input type="text"/>
	Set
Trigger B	<input type="text"/>
	Set
<input type="checkbox"/> Write to SD memory card	

2. Select a trigger number, sampling condition, trigger mode, trigger position and trigger condition.

3. Press either [Set] button of Trigger A or B according to the trigger condition. The "Trigger Setting" dialog box is displayed.

Trigger Setting

Setting object: Trigger A

Comparison source: [Dropdown]

Object: MC Unit

Classification: All

Device: Each axis connection confirmatio

Axis number: Axis 1

Device type: Bit device

Used bit position: 0

Comparison destination: [Dropdown]

Object: MC Unit

Classification: All

Device: Each axis connection confirmatio

Axis number: Axis 1

Device type: Bit device

Used bit position: 0

OK Cancel

4. Select trigger setting conditions, and press the [OK] button.

The detailed information of trigger conditions is displayed.

Trigger condition setting

Trigger no.: 1

Sampling

Communication cycle (ms): 0.5

Communication cycle magnification: 1

Sampling cycle (ms): 0.5

Measurement time (ms): 512

No. of sampling data: 1024

Trigger mode: Single

Trigger position: 1/8

Trigger condition: A

Trigger A

Axis 1:Positioning start request ↑ Fixed value:0

Set

Trigger B

Set

Write to SD memory card

### 14.3.2 Trigger Condition Setting (Sampling)

The sampling conditions in the Trigger condition setting dialog box are set as follows.

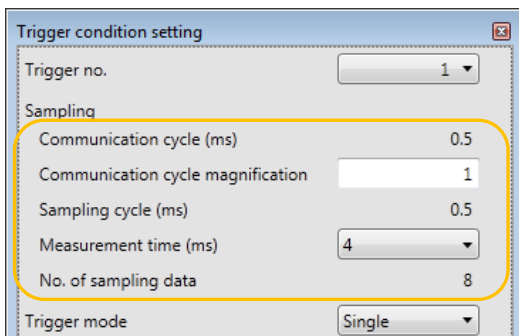

■ Setting item

Item	Description										
Communication cycle	The set EtherCAT communication cycle is displayed. Although the communication cycle specified in "MC common settings" is in [ $\mu$ s] unit, the communication cycle is displayed in [ms] unit according to the time scale display.										
Communication cycle magnification	Set the EtherCAT communication cycle magnification. Range: 1 to 255										
Sampling cycle	The determined sampling cycle is displayed according to the above communication cycle magnification.										
Measurement time (ms)	Select data measurement time. The range of measurable time varies according to the EtherCAT communication cycle. <table border="1" style="width: 100%; border-collapse: collapse;"> <thead> <tr> <th>EtherCAT communication cycle</th> <th>Measurement time range</th> </tr> </thead> <tbody> <tr> <td>0.5 ms</td> <td>4 ms to 130.560 s</td> </tr> <tr> <td>2.0 ms</td> <td>6 ms to 522.240 s</td> </tr> <tr> <td>1.0 ms</td> <td>8 ms to 261.120 s</td> </tr> <tr> <td>4.0 ms</td> <td>32 ms to 1,044.480 s</td> </tr> </tbody> </table>	EtherCAT communication cycle	Measurement time range	0.5 ms	4 ms to 130.560 s	2.0 ms	6 ms to 522.240 s	1.0 ms	8 ms to 261.120 s	4.0 ms	32 ms to 1,044.480 s
EtherCAT communication cycle	Measurement time range										
0.5 ms	4 ms to 130.560 s										
2.0 ms	6 ms to 522.240 s										
1.0 ms	8 ms to 261.120 s										
4.0 ms	32 ms to 1,044.480 s										
No. of sampling data	The number of data sampled is displayed according to the above settings. No. of sampling data = Measurement time / Sampling cycle										

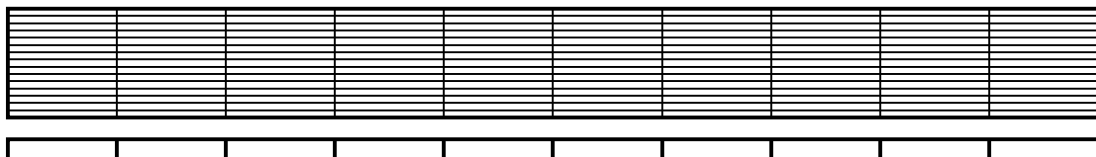

◀ ..... Measurement time [EtherCAT communication cycle x Communication cycle magnification x No. of sampling data] ..... ▶

(0.004 s to 1,044,480 s)

EtherCAT communication cycle: 500/1,000/2,000/4,000  $\mu$ s  
 Cycle magnification: 1 to 255  
 No. of sampling data: 8 to 1,024  
 Sampling cycle: Measurement time / No. of sampling data

### 14.3.3 Trigger Condition Setting (Trigger Mode/Trigger Position)

"Trigger mode" and "Trigger position" in the Trigger condition setting dialog box are set as follows.

Trigger condition setting

Trigger no. 1

Sampling

Communication cycle (ms) 0.5

Communication cycle magnification 1

Sampling cycle (ms) 0.5

Measurement time (ms) 4

No. of sampling data 8

Trigger mode Single

Trigger position 0

Trigger condition A

#### ■ Setting item

Item	Description								
Trigger mode	Specifying the timing to log data.								
	<table border="1"> <thead> <tr> <th>Select</th> <th>Description</th> </tr> </thead> <tbody> <tr> <td>Single</td> <td>After the start request, the logging is executed only at the time of the first trigger detection.</td> </tr> <tr> <td>Normal</td> <td>After the start request, the logging is executed every time the trigger is detected.</td> </tr> <tr> <td>Auto</td> <td>After requesting the start, the data before the measurement time will be stored as measurement data from the point of time when the logging stop is requested.</td> </tr> </tbody> </table>	Select	Description	Single	After the start request, the logging is executed only at the time of the first trigger detection.	Normal	After the start request, the logging is executed every time the trigger is detected.	Auto	After requesting the start, the data before the measurement time will be stored as measurement data from the point of time when the logging stop is requested.
	Select	Description							
	Single	After the start request, the logging is executed only at the time of the first trigger detection.							
Normal	After the start request, the logging is executed every time the trigger is detected.								
Auto	After requesting the start, the data before the measurement time will be stored as measurement data from the point of time when the logging stop is requested.								
Trigger position	Trigger positions displayed on the time chart monitor can be specified. They can be set by the rate of the measurement time. Select any one from the following options. 0, 1/8, 2/8, 3/8, 4/8, 5/8, 6/8, 7/8								
Trigger position									

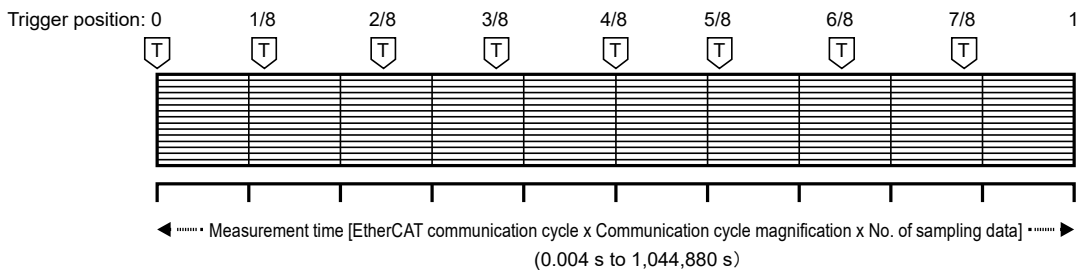

### 14.3.4 Trigger Condition Setting (Trigger Condition)

"Trigger condition", "Trigger A" and "Trigger B" in the Trigger condition setting dialog box are set as follows.

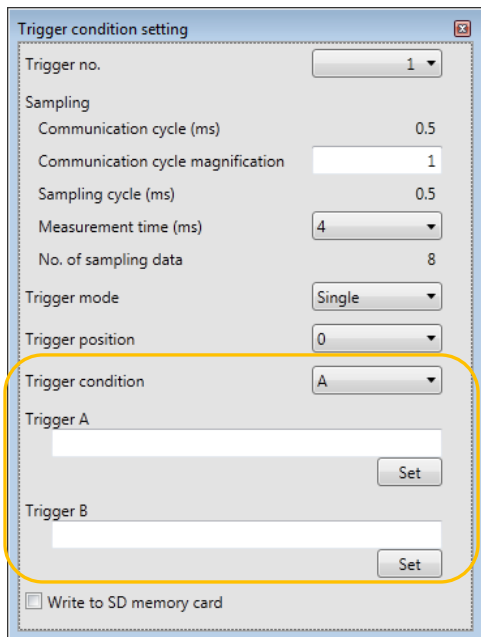

■ Setting item

Item	Description	
Trigger condition	Select a condition for the corresponding trigger number.	
	A	It will be valid when the condition specified for Trigger A is met.
	B	It will be valid when the condition specified for Trigger B is met.
	A and B	It will be valid when the both conditions specified for Trigger A and Trigger B are met.
A or B	It will be valid when the condition specified for Trigger A or Trigger B is met.	
Trigger A	Click [Set] button to open the "Trigger Setting" dialog box.	
Trigger B		



■ "Trigger Setting" dialog box

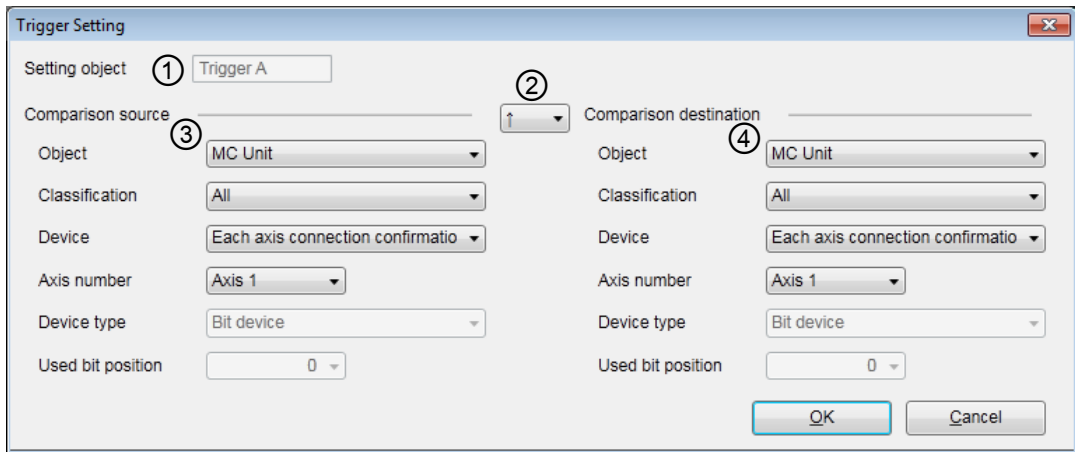

No.	Item	Description
①	Setting object	The trigger for the setting is displayed.
②	Comparison condition	Select comparison conditions to enable the trigger.
		↑ It will be valid when the leading edge (off to on) of the "condition set for Comparison source" is detected.
		↓ It will be valid when the trailing edge (on to off) of the "condition set for Comparison source" is detected.
		↑↓ It will be valid when the leading edge (off to on) or trailing edge (on to off) of the "condition set for Comparison source" is detected.
		= It will be valid when "condition set for Comparison source" is equal to "condition set for Comparison destination".
		< > It will be valid when "condition set for Comparison source" is not equal to "condition set for Comparison destination".
		≧ It will be valid when "condition set for Comparison source" is larger than or equal to "condition set for Comparison destination".
		≦ It will be valid when "condition set for Comparison source" is smaller than or equal to "condition set for Comparison destination".
③	Comparison source	Select devices for the comparison conditions. A fixed value can be selected for Comparison source.
④	Comparison destination	

## 14.4 Download to Setting Data to the Unit

---

The device registration and trigger conditions made by "CMTimeChart" must be downloaded to FP7 MC Unit. The following procedure is explained on the condition that "CMTimeChart" has already started on CMI.



### ◆ PROCEDURE

---

1. Select "Online" > "Download Logging Setting" from the menu bar.

A confirmation message box is displayed.

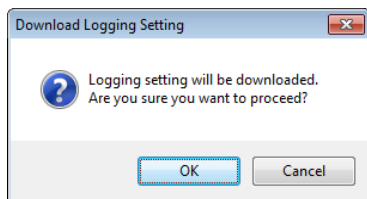

2. Press the [OK] button.

Downloading the logging setting is executed. Once the download is complete, a message box is displayed.

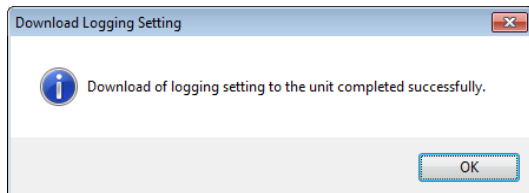

When the logging operation is performed, the following message box is displayed. Confirm that the logging flag is off by the logging monitor function of "CMTimeChart" and re-execute the download again.

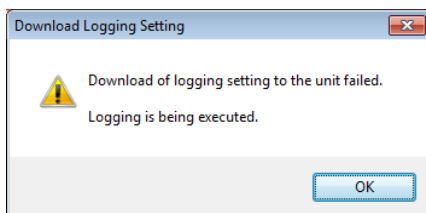

3. Press the [OK] button.

## 14.5 Start and Stop of Logging Operation

### 14.5.1 Procedures of Start and Stop by "CMTimeChart"

The logging operation of FP7 MC Unit can be operated on "CMTimeChart". The following procedure is explained on the condition that "CMTimeChart" has already started on CMI.



#### ◆ PROCEDURE

1. Select "Online" > "Download Logging Setting" from the menu bar.

"Announce Trigger Registration" and "Allow Trigger Use" turn on in the "Logging Monitor" window.

Logging Monitor												
Trigger State	T01	T02	T03	T04	T05	T06	T07	T08	T09	T10	T11	T12
Announce Trigger Registration	ON	-	-	-	-	-	-	-	-	-	-	-
Allow Trigger Use	ON	-	-	-	-	-	-	-	-	-	-	-
Logging flag	-	-	-	-	-	-	-	-	-	-	-	-
Presence/absence of logging data	-	-	-	-	-	-	-	-	-	-	-	-

2. Select "Online" > "Start Logging" from the menu bar.

A confirmation message box appears.

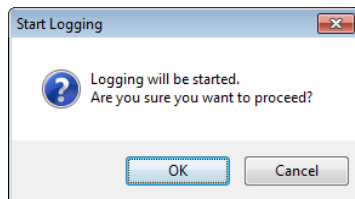

3. Press the [OK] button.

Once a trigger is detected, the logging is started and the logging flag turns on.

Logging Monitor												
Trigger State	T01	T02	T03	T04	T05	T06	T07	T08	T09	T10	T11	T12
Announce Trigger Registration	ON	-	-	-	-	-	-	-	-	-	-	-
Allow Trigger Use	ON	-	-	-	-	-	-	-	-	-	-	-
Logging flag	ON	-	-	-	-	-	-	-	-	-	-	-
Presence/absence of logging data	-	-	-	-	-	-	-	-	-	-	-	-

Once the logging is finished, the logging flag turns off and the presence/absence of logging data flag turns on.

Logging Monitor												
Trigger State	T01	T02	T03	T04	T05	T06	T07	T08	T09	T10	T11	T12
Announce Trigger Registration	ON	-	-	-	-	-	-	-	-	-	-	-
Allow Trigger Use	ON	-	-	-	-	-	-	-	-	-	-	-
Logging flag	-	-	-	-	-	-	-	-	-	-	-	-
Presence/absence of logging data	ON	-	-	-	-	-	-	-	-	-	-	-

4. Confirm if the presence/absence of logging data flag is on.
5. Select "Online" > "Stop Logging" from the menu bar.

A confirmation message appears.

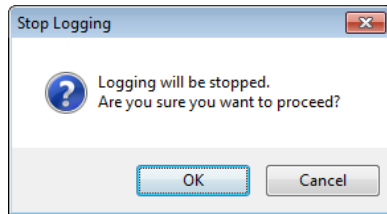

6. Press the [OK] button.

The logging operation stops and a confirmation message are displayed.

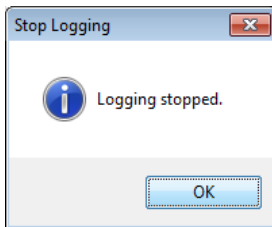

7. Press the [OK] button.

Then upload the logging data on "CMTimeChart". It can be displayed in the time chart.



---

#### ◆ KEY POINTS

---

- When the trigger mode is "Auto", pressing the [OK] button in step 3 turns on the logging flag. Also, executing the logging stop after step 5 turns on the presence/absence of logging data flag. For information on the difference between operations according the trigger modes, refer to "14.5.3 Logging Operation Diagram".

## 14.5.2 Start/Stop by User Programs

The logging operation of FP7 MC Unit can be operated by user programs. The operation by user programs is performed by I/O and unit memories.



### ◆ PROCEDURE

1. Confirm if the trigger conditions of a corresponding trigger number has been registered in the unit by "Announce Trigger Registration (UM02630)" in the unit memories.
2. Write "1" to the corresponding bit of "Allow Trigger Use (UM02631)" in the unit memories.
3. Turn on "Waveform logging enable (YB)".
4. Confirm if the logging of the corresponding trigger number is complete by "Presence/absence of logging data (UM02633)" in the unit memories.
5. Turn off "Waveform logging enable (YB)".

The logging operation stops. Then upload the logging data on "CMTimeChart". It can be displayed in the time chart.

### ■ I/O allocation

I/O number	Target axis	Name	Description
YB	All axes	Waveform logging enable	When this signal is on, the waveform logging can be executed. When this signal is off, the waveform logging cannot be executed. When this flag turns off, while the waveform logging is being executed, the waveform logging is aborted.
XB	All axes	Waveform logging active annunciation	This contact turns on by turning on the waveform logging enable flag (YB).

(Note 1): The I/O numbers in the above table show relative addresses based on the base word number. The I/O numbers actually used vary according to the slot number where the unit is installed and the starting word number.

■ Unit memories (Time chart function operation setting/annunciation area)

●: Available, -: Not available

Axis no.	Unit memory no. (Hex)	Name	Default	Description	R	W
-	UM 02630	Announce trigger registration	H0	When a trigger condition has been registered in FP7 MC Unit, the bit corresponding to the trigger number turns on. 0: Not registered 1: Trigger condition is registered.	●	-
-	UM 02631	Allow trigger use	H0	For allowing the use of a trigger by a user program, turn the bit corresponding to the trigger number. 0: Not allow the use. 1: Allow the use.	●	●
-	UM 02632	Logging flag	H0	It turns on when the logging operation is being executed on FP7 MC Unit. It turns off when the logging operation is complete. 0: Logging is not executed / complete. 1: During logging	●	-
-	UM 02633	Presence/absence of logging data	H0	It turns on when the logging operation is complete on FP7 MC Unit and logging data exists. 0: No logging data 1: Logging data exists.	●	-

(Note 1): Sixteen bits corresponding to respective trigger numbers are allocated to the time chart function operation setting/annunciation area (1 word).

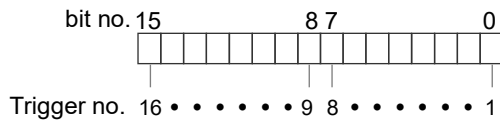

### 14.5.3 Logging Operation Diagram

The timing of sampling data by the logging operation of FP7 MC Unit varies according to the "Trigger mode" (Single / Normal / Auto) set in "CMTimeChart".

#### ■ When Trigger mode is "Single"

After the logging operation is executed, the data at the point of time when the first trigger condition is met will be logged and stored as data.

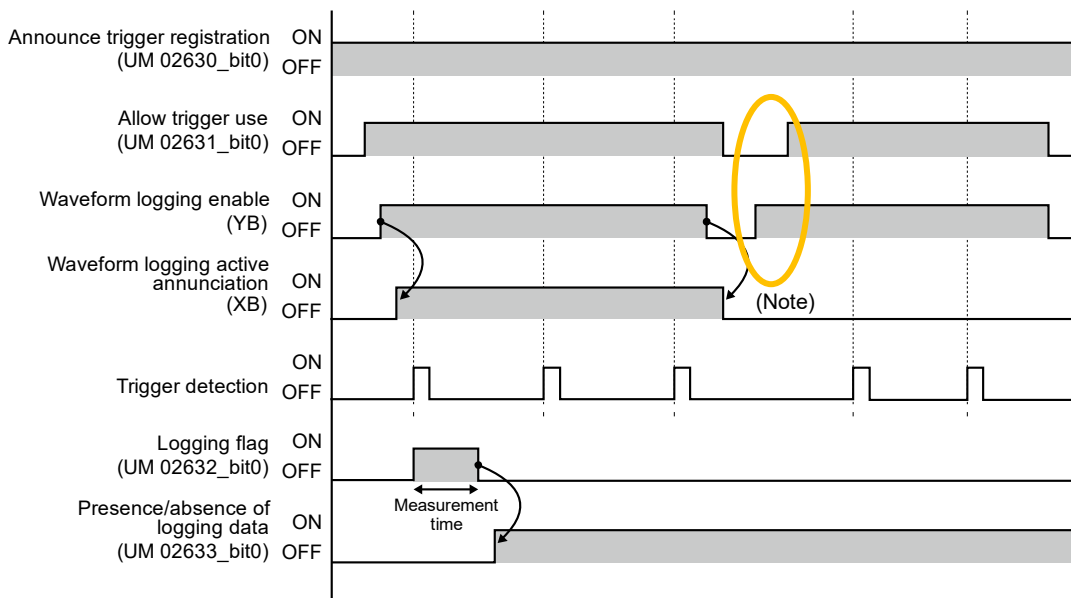

(Note): If the waveform logging enable (YB) flag turns on before turning on "Allow Trigger Use (UM02631)", the logging operation will not be executed.

■ When Trigger mode is "Normal"

After the logging operation is executed, the data at the point of time whenever the trigger condition is met will be logged and stored as data. When the "Upload logging data" operation is performed on CMTimeChart, the time chart displays only the latest information.

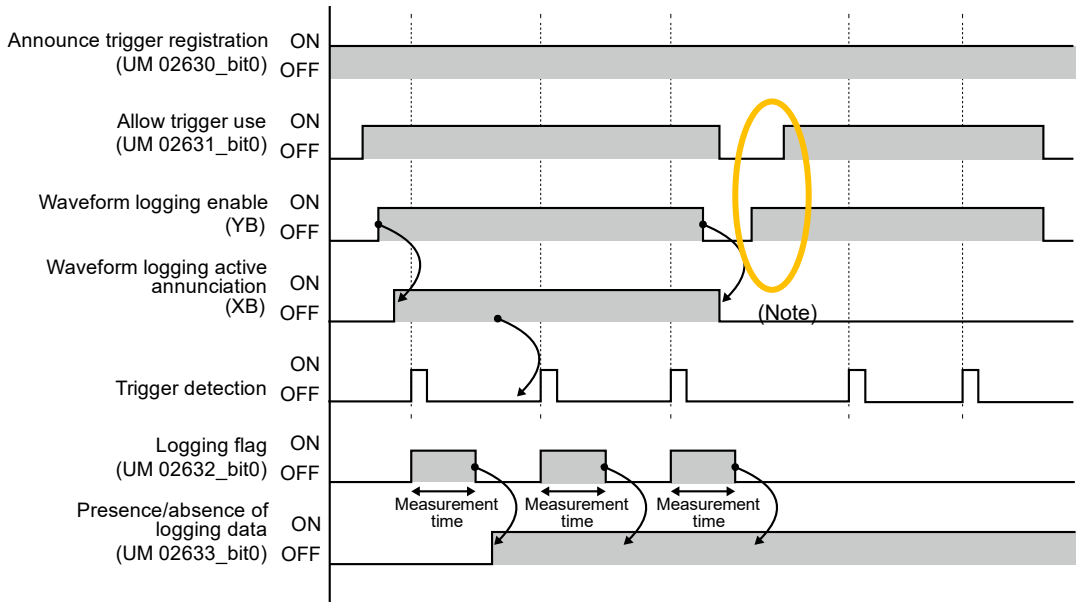

(Note): If the waveform logging enable (YB) flag turns on before turning on "Allow Trigger Use (UM02631)", the logging operation will not be executed.



■ When Trigger mode is "Auto"

While the logging enable flag (YB) is on, the logging operation is continued and data is stored. Once the logging enable flag (YB) turns off, the data from the time traced back by the measurement time specified in "CMTIMEChart" until the stop will be stored.

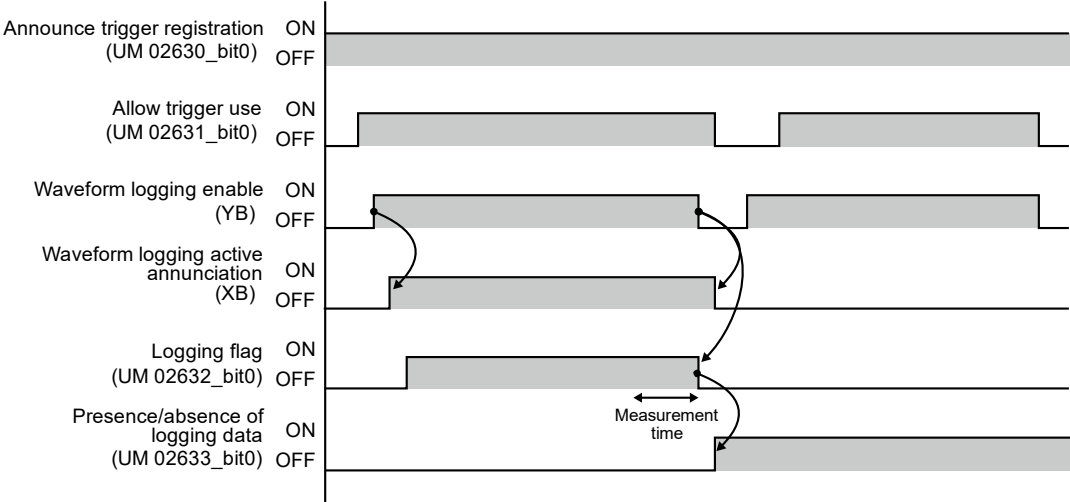

## 14.6 Upload of Logging Data (Time Chart)

### 14.6.1 Procedure of Uploading Logging Data

Data logged in FP7 MC Unit can be read on "CMTimeChart" and displayed as a time chart. The following procedure is explained on the condition that the logging is complete and "CMTimeChart" has already started on CMI.



#### ◆ PROCEDURE

1. Confirm that the logging is complete, the operation is stopped and the Presence/absence of logging data flag is on.

This can be confirmed in the "Logging Monitor" window.

Logging Monitor												
Trigger State	T01	T02	T03	T04	T05	T06	T07	T08	T09	T10	T11	T12
Announce Trigger Registration	ON	-	-	-	-	-	-	-	-	-	-	-
Allow Trigger Use	ON	-	-	-	-	-	-	-	-	-	-	-
Logging flag	-	-	-	-	-	-	-	-	-	-	-	-
Presence/absence of logging data	ON	-	-	-	-	-	-	-	-	-	-	-

2. Select "Online" > "Upload Logging Data" from the menu bar.

A confirmation message box appears.

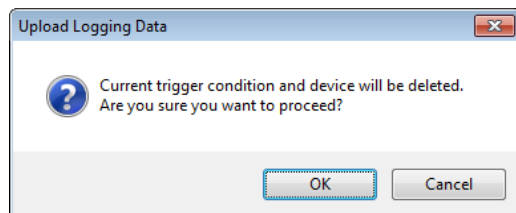

3. Press the [OK] button.

The upload is executed and a confirmation message box is displayed.

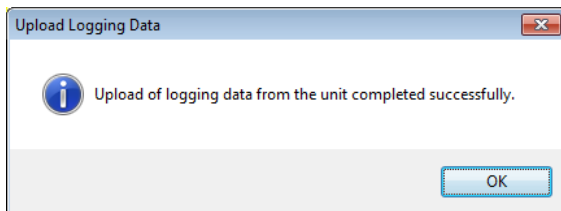

4. Press the [OK] button.

The logged data is displayed as a time chart.

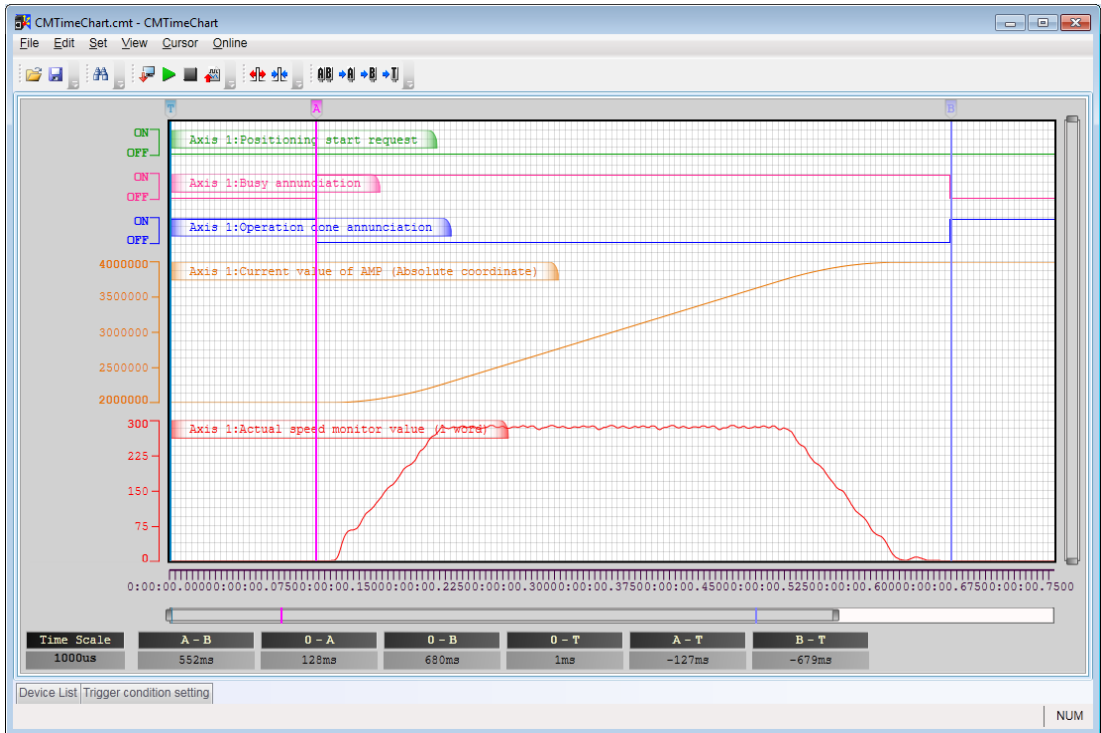

### ◆ KEY POINTS

- For uploading logging data and displaying the time chart, the logging operation should be complete.
- During the execution of the logging operation, it is not possible to upload logging data and start the time chart.

## 14.6.2 Settings for Time Chart Display Area

The display of "CMTimeChart" can be adjusted in the Display Setting dialog box. Selecting "View" > "View Setting..." opens the Display Setting dialog box.

### ■ Display Setting dialog box (Common tab)

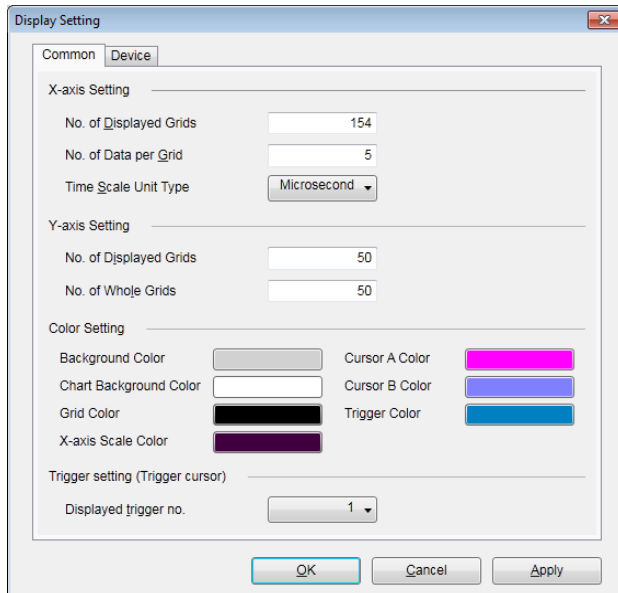

Item		Description
X-axis Setting	No. of Displayed Grids	Set the number of grids of a displayed chart in the logging monitor. Range: 10 to 1,000 (Example) When setting 10, it is divided into 10 by grids.
	No. of Data per Grid	Set the number of data dividing the area between grids. Range: 1 to 100 (Example) No. of Data per Grid: 10 (Set the time rate of one grid regarding one is equal to a time scale.)
	Time Scale Unit Type	Set the time scale unit of a displayed chart. Microsecond / msec / sec / min / hours
Y-axis Setting	No. of Displayed Grids	Set the number of grids displayed in a displayed chart in the logging monitor. Range: 10 to 50
	No. of Whole Grids	Set the total number of grids displayed in the logging monitor.
Color Setting		Set display colors.
Trigger Setting		Select a trigger number to be displayed. Range: 1 to 16

Displayed Grids

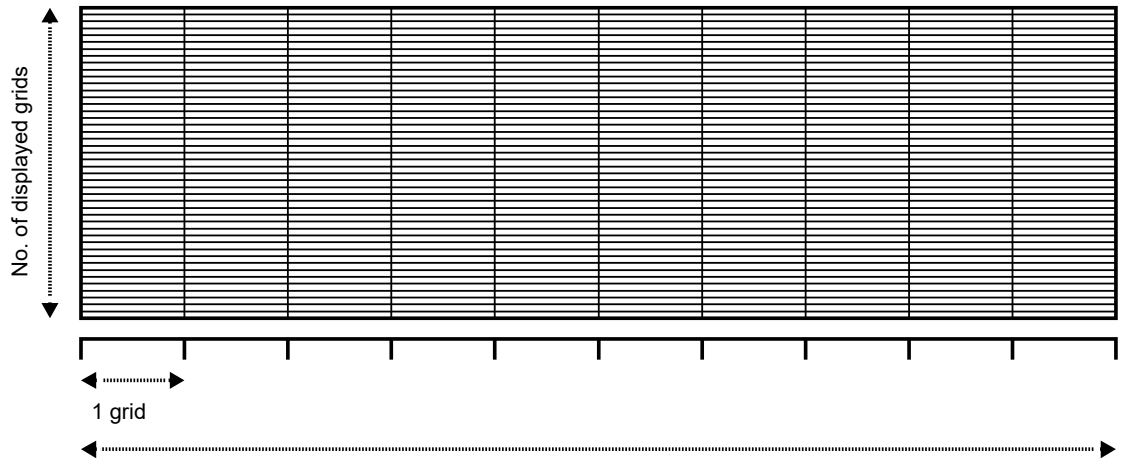

$$\text{Time in display} = \frac{\text{Time scale}}{1 \text{ data}} \times \text{No. of data per grid} \times \text{No. of displayed grids}$$

Color Setting

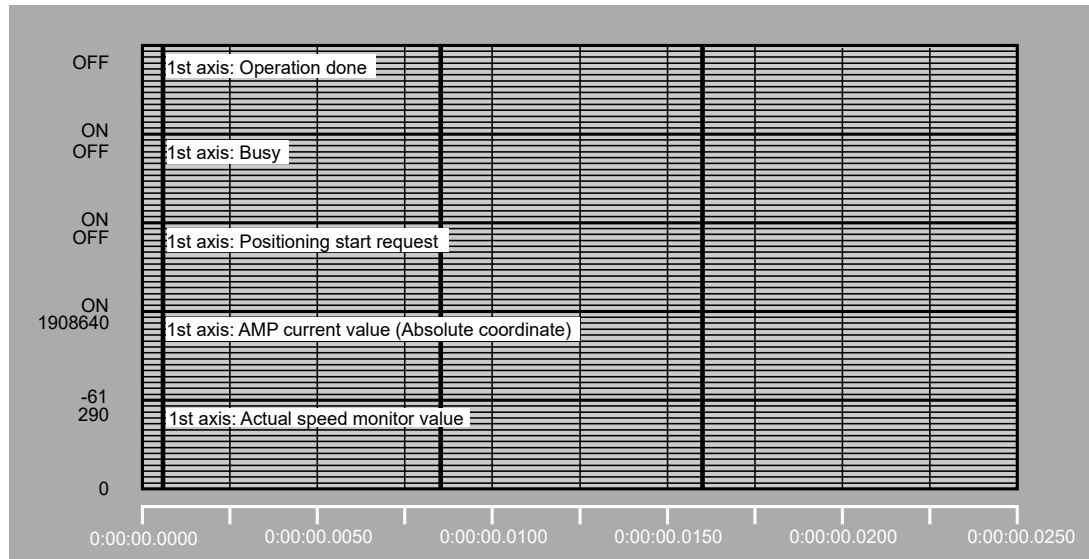

■ **Display Setting dialog box (Device tab)**

The display range and position can be set for each registered device.

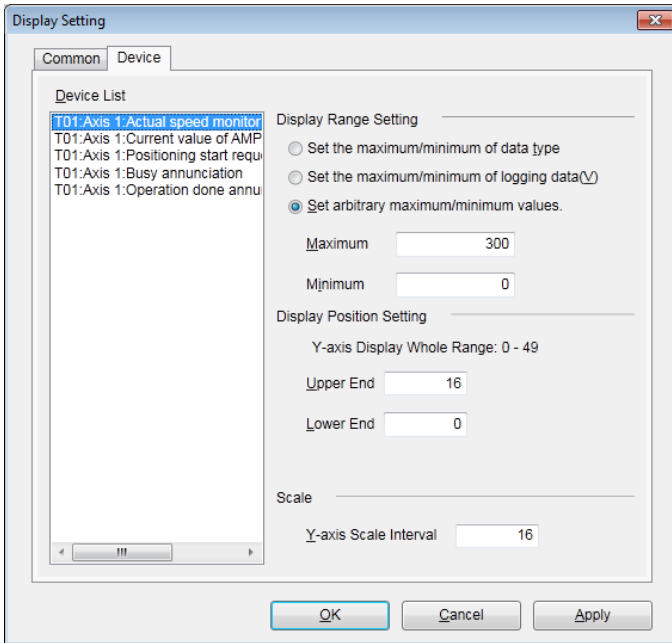

(Note): In Scale field, enter an interval between the scales of Y axis by grids. Range: 1 to (Upper end - Lower end)

## 14.7 Storage of CMTIMECHART DATA

---

Conditions and data set in "CMTIMECHART" can be stored as files. Store them after uploading data. The following procedure is explained on the condition that the logging is complete and "CMTIMECHART" has already started on CMI.



### ◆ PROCEDURE

---

---

1. Select "File" > "Save As" from the menu bar.
2. Enter the desired file name and press [Save].

It can be stored as a file with the extension (.cmt).



### ◆ KEY POINTS

---

---

- By opening the file and downloading the setting data to the unit gain, the logging operation can be performed under the same conditions.

## 14.8 Storage in SD Memory Card

### 14.8.1 Storing Logging Data

Data logged in the memory of FP7 MC Unit can be stored in SD memory cards.

#### ■ Specifications

Item	Specifications
Number of logs	Max. 256 devices
Buffer memory	Max. 32k words It can be divided into max. 16 (DATALOG0 to DATALOG15) areas for use. Capacity per division: 2k words to 32k words
Start/Stop of logging	The logging enable flag (YB) turns on by CMTimeChart or a user program.
Logging trigger condition	When the trigger condition is met; Instruction: The waveform logging enable flag (YB) is executed under arbitrary conditions and logging starts.
File determination condition (Logging stop trigger condition)	When logging is complete.
File format	Data is saved in log format.

#### ■ Folders and files stored in an SD memory card

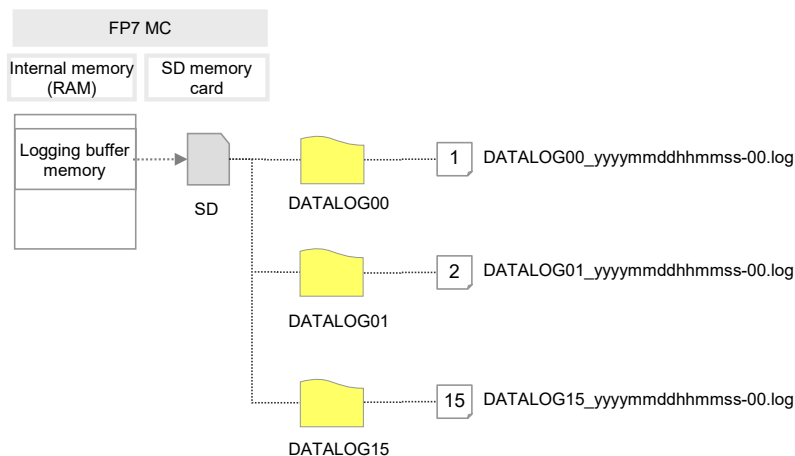



## 14.8.2 Setting When Using SD Memory Cards

Make the following settings to store logging data of FP7 MC Unit.

### ■ Setting of time data acquisition

When storing logging data of FP7 MC Unit in an SD memory card, the time data of FP7 CPU Unit is used. For acquiring the time data of FP7 CPU Unit, make the following settings.



### ◆ PROCEDURE

1. Select "Options" > "FP7 Configuration" > "CPU configuration" from the menu bar of FPWIN GR7.

The "CPU Configuration Setting" dialog box appears.

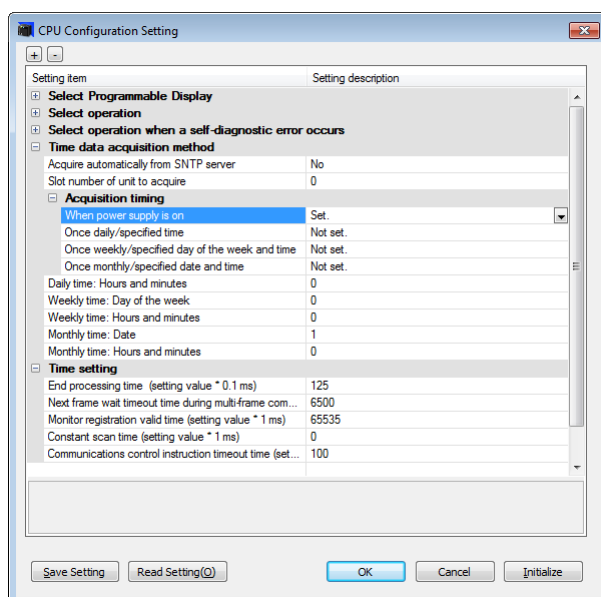

2. Specify the slot number where FP7 MC Unit is installed for "Slot number of unit to acquire".
3. Change the setting of "When power supply is on" under "Acquisition timing" to "Set".

A confirmation message box appears.

4. Press the [OK] button.

■ **Setting of trigger conditions**

For storing logging data of FP7 MC Unit in an SD memory card, check the checkbox of "Write SD memory card" in the "Trigger condition setting" dialog box.

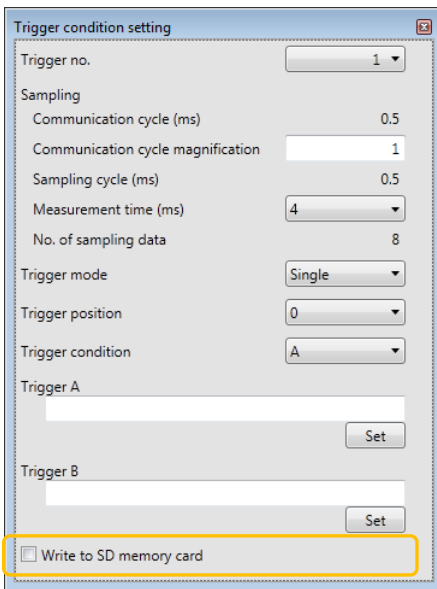

◆ **KEY POINTS**

---

- **Even when using an SD memory card, the operations such as registering devices, setting trigger conditions, downloading setting data, starting/stopping logging operation and uploading logging data are the same.**

# 15

## Troubleshooting

## 15.1 Errors and Warnings

### 15.1.1 Errors and Warnings

When any operational unconformity occurs in FP7 MC Unit, errors or warnings will occur. When errors or warnings occur, the following operations will be performed.

<b>Error</b>	Occurs in any abnormal conditions. When a motor is operating, the operation stops. The motor stopped due to the occurrence of error will not activate until the error clear is executed.
<b>Warning</b>	Occurs when any operational unconformity not abnormal conditions exist. The operation can continue even after the occurrence of warnings, and the motor continues running if the motor is operating.

### 15.1.2 Checking and Clearing by CMI

It is possible to check and clear errors/warning on an axis-by-axis basis by selecting [Online] > [Data monitor] on the programming tool CMI. Some errors cannot be cleared. Some system errors and communication errors of AMP cannot be cleared by this operation. The power supply of the unit should be restored.

Axis [Group]	Axis 1	Axis 2	Axis 3	Axis 4	V-axis 1
Control mode	Positioning control	Positioning control	Positioning control	Positioning control	JOG operation
Synchronous master axis	V-Axis 1	V-Axis 1	-----	-----	-----
Synchronous output	Cam	Gear+Clutch	-----	-----	-----
Synchronous state	Synchronize	Synchronize	-----	-----	-----
Table number executing	1	1	1	1	1
Auxiliary output code	0	0	0	0	0
Repeat count current value	0	0	0	0	0
Repeat count	0	0	0	0	0
Current value	0	7	0	-1	424
Unit conversion current value	0 pulse	7 pulse	0 pulse	-1 pulse	424 pulse
Deviation	0	0	1	-1	-----
Torque value (%)	0	0	0	0	-----
Actual speed (rpm)	0	0	0	0	-----
Axis state	<b>Error occurs</b>	<b>Error occurs</b>	During stop	During stop	<b>Error occurs</b>
Error code	00F0-3011	00F0-3043	-----	-----	00F0-3043
	Clear errors	Clear errors	Clear errors	Clear errors	Clear errors
Warning code	-----	-----	-----	-----	-----
	Clear warning	Clear warning	Clear warning	Clear warning	Clear warning

### 15.1.3 Clearing Errors/Warnings Using User Programs

Errors and warnings can be cleared by turning on the "error clear request" or "warning clear request" allocated to the output control area using user programs.

#### ■ Clearing errors/warnings using unit memories (output control area)

It is possible to clear errors and warnings on an axis-by-axis basis by turning on the error/warning clear request flags allocated to the output control area. Some errors cannot be cleared. Some system errors and communication errors of AMP cannot be cleared by this operation. The power supply of the unit should be restored.

(Example) When clearing the error in the axis no.1 of FP7 MC Unit installed in slot 1

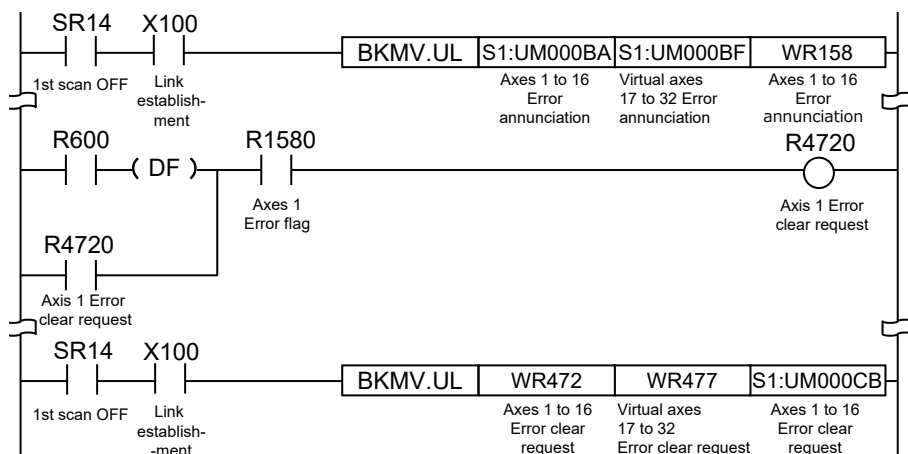

#### ■ Allocation of unit memories (Input control area/Output control area)

Signal name	Real axis				Virtual axis	
	Axes 1-16	Axes 17-32	Axes 33-48	Axes 49-64	Axes 1-16	Axes 17-32
Error annunciation	UM000BA	UM000BB	UM000BC	UM000BD	UM000BE	UM000BF
Warning annunciation	UM000C0	UM000C1	UM000C2	UM000C3	UM000C4	UM000C5
Error clear request	UM001C8	UM001C9	UM001CA	UM001CB	UM001CC	UM001CD
Warning clear request	UM001CE	UM001CF	UM001D0	UM001D1	UM001D2	UM001D3

(Note 1): Flags or request signals for 16 axes are allocated to each unit memory (1 word) in the above table. When the value of each bit is 1, it turns on. When the value of each bit is 0, it turns off.

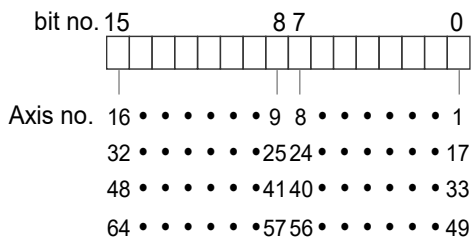

### 15.1.4 Error and Warning Logs

FP7 MC Unit has log areas to store error and warning codes in its unit memories.

- Once an error/warning occurs, the error/warning code will be stored in the log area of the axis that the error occurred.
- When an error/warning that is not related to the axes occurs, such as a failure in the unit, the error/warning code will be stored in the log areas of all axes.
- In the data monitor or tool operation dialog box on CMI, only the latest error and warning codes of each axis can be confirmed.
- For referring the error and warning logs for each axis, read the following unit memory from the PLC.

■ **Configuration of log areas**

Classification	Classification	Function
Error annunciation & clear area	Error clear individual axis setting	
	No. of occurrences of errors	The number of occurred errors is stored.
	Error code buffer 1	Up to eight error codes per axis are stored.
	-----	Eight-digit hex codes are stored as error codes.
	Error code buffer 8	The buffer 1 is always the latest code. Error codes are stored in the occurrence order from the buffer 1.
Warning annunciation & clear area	Warning clear individual axis setting	
	No. of occurrences of warnings	The number of occurred warnings is stored.
	Warning code buffer 1	Up to eight warning codes per axis are stored.
	-----	The buffer 1 is always the latest code. Warning codes are stored in the occurrence order from the buffer 1.
	Warning code buffer 8	



◆ **REFERENCE**

- For details of the log areas, refer to "16.5.10 Error Annunciation and Clear Area" and "16.5.11 Warning Annunciation and Clear Area".

---

## 15.2 Error Recovery Process

---

### 15.2.1 Overview

---

The method to recover from error occurrence varies according to the states when errors occur.

Status when an error occurred	Description	Error type
Recoverable state	-After an error occurred, the operating axes stop. -After an error occurred, FP7 MC Unit can recover the error at any time.	All error types
Unrecoverable state	- Error when a critical trouble occurred on the FP7 MC Unit system - When an unrecoverable error occurred, the power supply of the positioning unit should be restored.	System errors AMP communication errors

## 15.3 Error Code Table

---

### 15.3.1 AMP Errors (From 00FF 0000H)

---

- Alarms/errors occurred on the AMP side are output from FP7 MC Unit as error codes.
- The AMP errors differ depending on the types of AMP. For details of the processing for AMP errors, refer to the manual of servo amplifiers.
- When an AMP error occurs, the servomotor automatically becomes free. Execute the servo on request again after clearing the error.

■ **How to read AMP error codes**

- An AMP error is divided into a main code and sub code.
- The error codes stored in the error annunciation area of FP7 MC Unit are hexadecimal 4-digit codes. The main codes (decimal) of AMP errors are converted to hexadecimal and stored. The error codes equivalent to sub codes are not stored.

Example) For encoder communication errors

FP7 MC error code	A6B error no.		Description
	Main	Sub	
0015H	21	0	Encoder communication disconnect error protection
	21	1	Encoder communication error protection



■ AMP error code table [For A6B]

FP7 MC error code	A6B error no.		Description
	Main	Sub	
000BH	11	0	Control power supply under voltage protection
000CH	12	0	Over-voltage protection
000DH	13	0	Main power supply under voltage protection (between P to N)
	13	1	Main power supply under voltage protection (AC interception detection)
000EH	14	0	Over-current protection
	14	1	IPM error protection
000FH	15	0	Over-heat protection
	15	1	Encoder over-heat error protection
0010H	16	0	Over-load protection
	16	1	Torque saturation error protection
0012H	18	0	Over-regeneration load protection
	18	1	Regenerative transistor error protection
0015H	21	0	Encoder communication disconnect error protection
	21	1	Encoder communication error protection
0017H	23	0	Encoder communication data error protection
0018H	24	0	Position deviation excess protection
	24	1	Speed deviation excess protection
0019H	25	0	Hybrid deviation excess error protection
001AH	26	0	Over-speed protection
	26	1	2nd over-speed protection
001BH	27	1	Absolute clear protection
	27	4	Position command error protection
	27	6	Operation command contention protection
001CH	28	0	Pulse regeneration limit protection
001DH	29	2	Counter overflow protection 2
001FH	31	0	Safety function error protection 1
	31	2	Safety function error protection 2
0021H	33	0	Duplicated input allocation error 1 protection
	33	1	Duplicated input allocation error 2 protection
	33	2	Input function number error 1 protection
	33	3	Input function number error 2 protection
	33	4	Output function number error 1 protection
	33	5	Output function number error 2 protection
	33	8	Latch input allocation error protection
0022H	34	0	Software limit protection
	34	1	One revolution absolute working range error

(Note): Refer to the latest instruction manual and technical materials of the servo amplifier.

## Troubleshooting

FP7 MC error code	A6B error no.		Description
	Main	Sub	
0024H	36	0	EEPROM parameter error protection
	36	1	EEPROM parameter error protection
0025H	37	0	EEPROM check code error protection
	37	1	EEPROM check code error protection
	37	2	EEPROM check code error protection
0026H	38	0	Over-travel inhibit input protection 1
	38	1	Over-travel inhibit input protection 2
0028H	40	0	Absolute system down error protection
0029H	41	0	Absolute counter over error protection
002AH	42	0	Absolute over-speed error protection
002CH	44	0	Absolute single turn counter error protection
002DH	45	0	Absolute multi-turn counter error protection
002FH	47	0	Absolute status error protection
0031H	49	0	Incremental encoder CS signal error protection
0032H	50	0	External scale connection error protection
	50	1	External scale communication error protection
	50	2	External scale communication data error protection
0033H	51	0	External scale status error protection 0
	51	1	External scale status error protection 1
	51	2	External scale status error protection 2
	51	3	External scale status error protection 3
	51	4	External scale status error protection 4
	51	5	External scale status error protection 5
0037H	55	0	A-phase connection error protection
	55	1	B-phase connection error protection
	55	2	Z-phase connection error protection
0046H	70	0	U-phase current detector error protection
	70	1	W-phase current detector error protection
0048H	72	0	Thermal error protection
0050H	80	0	ESM unauthorized request error protection
	80	1	ESM undefined request error protection
	80	2	Bootstrap requests error protection
	80	3	Incomplete PLL error protection
	80	4	PDO watchdog error protection
	80	6	PLL error protection
	80	7	Synchronization signal error protection

(Note): Refer to the latest instruction manual and technical materials of the servo amplifier.

FP7 MC error code	A6B error no.		Description
	Main	Sub	
0051H	81	0	Synchronization cycle error protection
	81	1	Mailbox error protection
	81	4	PDO watchdog error protection
	81	5	DC error protection
	81	6	SM event mode error protection
	81	7	SyncManager2/3 error protection
0054H	84	3	Synchronous establishment initialization error protection
0055H	85	0	TxPDO assignment error protection
	85	1	RxPDO assignment error protection
	85	2	Lost link error protection
	85	3	SII EEPROM error protection
0057H	87	0	Compulsory alarm input protection
0058H	88	0	Main power under voltage protection (AC insulation detection 2)
	88	1	Control mode setting error protection
	88	2	ESM requirements during operation error protection
	88	3	Improper operation error protection
005BH	91	1	Command error protection
005CH	92	0	Encoder data recovery error protection
	92	1	External scale data recovery error protection
	92	3	Multi-turn data upper-limit value disagreement error protection
005DH	93	2	Parameter setting error protection 2
	93	3	External scale connection error protection
	93	8	Parameter setting error protection 6
005EH	94	3	Home position return error protection 2
005FH	95	0	Motor automatic recognition error protection
	95	1	Motor automatic recognition error protection
	95	2	Motor automatic recognition error protection
	95	3	Motor automatic recognition error protection
	95	4	Motor automatic recognition error protection
0060H	96	2	Control unit error protection 1
	96	3	Control unit error protection 2
	96	4	Control unit error protection 3
	96	5	Control unit error protection 4
	96	6	Control unit error protection 5
	96	7	Control unit error protection 6
	96	8	Control unit error protection 7
—	Other numbers		Other error protections

(Note): Refer to the latest instruction manual and technical materials of the servo amplifier.

## Troubleshooting

### ■ AMP error code table [For A5B]

FP7 MC error code	A5B error no.		Description
	Main	Sub	
000BH	11	0	Control power supply under voltage protection
000CH	12	0	Over-voltage protection
000DH	13	0	Main power supply under voltage protection (between P to N)
	13	1	Main power supply under voltage protection (AC interception detection)
000EH	14	0	Over-current protection
	14	1	IPM error protection
000FH	15	0	Over-heat protection
0010H	16	0	Over-load protection
	16	1	Torque saturation error protection
0012H	18	0	Over-regeneration load protection
	18	1	Over-regeneration Tr error protection
0015H	21	0	Encoder communication disconnect error protection
	21	1	Encoder communication error protection
0017H	23	0	Encoder communication data error protection
0018H	24	0	Position deviation excess protection
	24	1	Speed deviation excess protection
0019H	25	0	Hybrid deviation excess error protection
001AH	26	0	Over-speed protection
	26	1	2nd over-speed protection
001BH	27	1	Absolute clear protection
	27	4	Position command error protection
	27	6	Operation command contention protection
	27	7	Position information initialization error protection
001CH	28	0	Pulse regeneration limit protection (Not supported)
001DH	29	2	Counter overflow protection 2
001EH	30	0	Safety function error protection 1 [Only special product supports this feature.]
0021H	33	0	Overlaps allocation error 1 protection
	33	1	Overlaps allocation error 2 protection
	33	2	Input function number error 1 protection
	33	3	Input function number error 2 protection
	33	4	Output function number error 1 protection
	33	5	Output function number error 2 protection
	33	8	Latch input allocation error protection

(Note): Refer to the latest instruction manual and technical materials of the servo amplifier.

FP7 MC error code	A5B error no.		Description
	Main	Sub	
0022H	34	0	Software limit protection
	34	1	One revolution absolute working range error
0024H	36	0	EEPROM parameter error protection
	36	1	EEPROM parameter error protection
	36	2	EEPROM parameter error protection
0025H	37	0	EEPROM check code error protection
	37	1	EEPROM check code error protection
	37	2	EEPROM check code error protection
0026H	38	0	Over-travel inhibit input protection 1
	38	1	Over-travel inhibit input protection 2
0028H	40	0	Absolute system down error protection
0029H	41	0	Absolute counter over error protection
002AH	42	0	Absolute over-speed error protection
002BH	43	0	Incremental encoder initialization error protection
002CH	44	0	Absolute single turn counter error protection / Incremental signal turn counter error protection
002DH	45	0	Absolute multi-turn counter error protection / Incremental multi-turn counter error protection
002FH	47	0	Absolute status error protection
0030H	48	0	Incremental encoder Z-phase error protection
0031H	49	0	Incremental encoder CS signal error protection
0032H	50	0	External scale connection error protection (Not supported)
	50	1	External scale communication error protection (Not supported)
0033H	51	0	External scale status 0 error protection (Not supported)
	51	1	External scale status 1 error protection (Not supported)
	51	2	External scale status 2 error protection (Not supported)
	51	3	External scale status 3 error protection (Not supported)
	51	4	External scale status 4 error protection (Not supported)
	51	5	External scale status 5 error protection (Not supported)
0037H	55	0	A-phase connection error protection (Not supported)
	55	1	B-phase connection error protection (Not supported)
	55	2	Z-phase connection error protection (Not supported)
0050H	80	0	ESM unauthorized request error protection
	80	1	ESM undefined request error protection
	80	2	Bootstrap requests error protection
	80	3	Incomplete PLL error protection
	80	4	PDO watchdog error protection
	80	6	PLL error protection
	80	7	Synchronization signal error protection

(Note): Refer to the latest instruction manual and technical materials of the servo amplifier.

## Troubleshooting

FP7 MC error code	A5B error no.		Description
	Main	Sub	
0051H	81	0	Synchronization cycle error protection
	81	1	Mailbox error protection
	81	4	PDO watchdog error protection
	81	5	DC error protection
	81	6	SM event mode error protection
	81	7	SyncManager2/3 error protection
0054H	84	3	Synchronous establishment initialization error protection
0055H	85	0	TxPDO assignment error protection
	85	1	RxPDO assignment error protection
	85	2	Lost link error protection
	85	3	SII EEPROM error protection
0057H	87	0	Compulsory alarm input protection
0058H	88	0	Main power under voltage protection (AC insulation detection 2)
	88	1	Control mode setting error protection
	88	2	ESM requirements during operation error protection
	88	3	Improper operation error protection
005BH	91	1	Command error protection
005CH	92	0	Encoder data recovery error protection
	92	1	External scale data recovery error protection (Not supported)
005DH	93	0	Parameter setting error protection 1
	93	2	Parameter setting error protection 2
	93	3	External scale connection error protection (Not supported)
	93	7	Parameter setting error protection 5
005EH	94	2	Home position return error protection 2
005FH	95	0	Motor automatic recognition error protection
	95	1	Motor automatic recognition error protection
	95	2	Motor automatic recognition error protection
	95	3	Motor automatic recognition error protection
	95	4	Motor automatic recognition error protection
0062H	98	4	Unusual communication IC initialization protection
—	Other numbers		Other error protections

(Note): Refer to the latest instruction manual and technical materials of the servo amplifier.

### 15.3.2 System Errors (From 00F0 1000H)

These are the errors that occur due to any failure within FP7 MC Unit. The system errors are defined as the fatal errors for the system.

●: Recoverable, -: Unrecoverable

Error code	Error name	Description	Object	Recovered	Countermeasures
1000H	System runaway	System runaway If the error occurs, the ALARM LED on the unit turns on.	All axes	-	Turn off the power supply and turn it on again. If an error occurs repeatedly, consult your Panasonic representative.
1001H	Hardware error	An error occurred in the hardware test when the power supply turned on.	All axes	-	
1002H	Unit error	Any error occurred in the internal processing.	All axes	-	
1010H	FROM write error	Any error occurred in the execution of writing to FROM. (Write error/Verify error/Erase error)	All axes	●	Execute writing to FROM again. If the error occurred repeatedly, please contact us.
1020H	Tool operation abnormal end	Any error occurred in the communication with a PC when executing the tool operation on CMI.	All axes	●	Check the connection of the cable connecting the PC and PLC. Reboot the PC.
1021H	Diagnosis mode abnormal end	Any error occurred in the communication with a PC when executing the diagnosis mode of CMI-Tool.	All axes	●	Check the connection of the cable connecting the PC and PLC. Reboot the PC.
1030H	CPU unit error	ALARM occurred in the CPU unit.	All axes	-	Check the condition of the CPU unit. Turn off the power supply and turn it on again.

(Note 1): To simplify the displays, only the lower four digits (Hex) of each error code are displayed in the above table.

(Note 2): The power supply must be turned off and on again to recover the errors whose "Recovered" column is "-".

### 15.3.3 AMP Communication Errors (From 00F0 2000H)

These are the errors occurred in the communication between FP7 MC Unit and AMP. They occur when the communication data was judged as abnormal.

●: Recoverable, -: Unrecoverable

Error code	Error name	Description	Object	Recovered	Countermeasures
2020H	AMP station address duplicate error	The AMPs with the same station address exist in the network.	All axes	-	After checking the station address settings of AMP, turn off the power supply and turn it on again.
2030H	AMP station address setting error	The AMP with a station address outside the settable range exists.	All axes	-	
2060H	No ENI file	No ENI file exists in FP7 MC Unit.	All axes	-	Download CMI project data.
2061H	Network configuration verify error	The network configuration defined in the ENI file is different from the actual network configuration.	All axes	-	Check whether the configuration matches the connection configuration set on CMI.
2062H	Process data receive timeout error	The PDO (Process data) communication error occurred.	All axes	-	Check the communication cable to see if it is correctly connected. Check the power supply of Servo Amplifier A6B/A5B.
2063H	SDO communication error	The SDO communication error occurred.	Each axis	●	- Check the setting parameters for SDO communication. - Check if there is anything wrong with SDO communication devices (slaves).
2064H	SDO communication timeout	The SDO communication timeout occurred.	Each axis	●	- Check if there is anything wrong with communication destination devices (slaves). - Check the connection of LAN cable.
2065H	PDO communication data size error	The PDO communication data size error occurred.	All axes/ Each axis	●	- Data exceeded the maximum data size for PDO communication (5736 bytes). - Data exceeded the maximum data size for PDO communication (1 node) (1 byte).
2070H	ESM change error	ESM could not be changed.	All axes/ Each axis	Conditional	- Make the ESM change control area setting correctly. * There are both cases that the error can be recovered and cannot be recovered.

(Note 1): To simplify the displays, only the lower four digits (Hex) of each error code are displayed in the above table.

(Note 2): The power supply must be turned off and on again to recover the errors whose "Recovered" column is "-".



### 15.3.4 Axis Operation Errors (From 00F0 3000H)

These are the errors occurred while various operations are being executed.

●: Recoverable, -: Unrecoverable

Error code	Error name	Description	Object	Recovered	Countermeasures
3000H	Not servo ready	The axis that servo is not locked was started.	Each axis	●	Confirm the servo is locked while each axis is operating
3001H	Servo off detection in operation	The servo became off during the operation being processed.	Each axis	●	Turn off the servo on input when the busy flag for the target axis is not on. Check the state of the AMP.
3005H	Main power supply OFF error	The servo on was requested when the main power supply of the AMP was off.	Each axis	●	- Turn the servo on after the main power supply has been turned on. - Check the voltage of the main power supply.
3010H	Limit + signal detection	The input on the plus side of the limit turned on.	Each axis	●	Move the motor into the range of the limit by an operation such as the JOG operation. Check the settings of Servo Amplifier and FP7 MC Unit to see if the limit input is correct.
3011H	Limit - signal detection	The input on the minus side of the limit turned on.	Each axis	●	
3012H	Limit signal error	Both inputs on the plus and minus sides of the limit turned on.	Each axis	●	Check the settings of Servo Amplifier and FP7 MC Unit to see if the limit input is correct.
3020H	Software limit (plus side) detection	The movement amount of the motor exceeded the upper limit of the software limit.	Each axis	●	Move the motor into the range of the software limit by an operation such as the JOG operation. Check the setting values of the software limit.
3021H	Software limit (minus side) detection	The movement amount of the motor exceeded the lower limit of the software limit.	Each axis	●	
3025H	Command speed operation error	The internal operation of command speed failed due to overflow.	Each axis	●	Lower the set speed. Check the settings of the pulse number per rotation and movement amount per rotation.
3030H	Axis operation error	An error occurred in the operation processing of each axis.	Each axis	●	Check the setting values and parameters of the positioning unit. If the error occurs repeatedly with the correct set values, consult your Panasonic representative.
3031H	Operation abnormal end	An error occurred in the operation processing of each axis.	Each axis All axes	●	If an error occurs repeatedly, consult your Panasonic representative.

(Note): To simplify the displays, only the lower four digits (Hex) of each error code are displayed in the above table.

## Troubleshooting

●: Recoverable, -: Unrecoverable

Error code	Error name	Description	Object	Recovered	Countermeasures
3032H	Axis group operation error	The setting of axis group was changed during the operation or when requesting the stop. The setting of axis group is out of the range.	Each axis	●	Changing the axis group should be performed when the axes are not in operation. Do not make a stop request, either. Check the axis group settings.
3033H	Interpolation operation error	The operation stopped as an error occurred on other interpolation axis during the interpolation operation.	Each axis	●	Check the set values for positioning data on interpolation. If the error occurs repeatedly with the correct set values, consult your Panasonic representative.
3035H	Positioning movement amount error	The positioning movement amount has exceeded the upper or lower limit.	Each axis	●	Check the set value.
3040H	Synchronous operation group error	The synchronous group was changed during the synchronous operation or when requesting the stop in the synchronous operation. The setting of synchronous group is out of range. An error occurred in the home return of the synchronous operation.	Each axis	●	Changing the synchronous group should be performed when the busy flag for the axes to be synchronized is off. Also, it should be performed when various stop requests (system stop, emergency stop, deceleration stop) are off.
3043H	Synchronous operation error	The operation has stopped as an error occurred on another axis while the positioning unit is in synchronous operation.	Each axis	●	Check the unit setting of the stopped axis. If the error occurs repeatedly with the correct set values, consult your Panasonic representative.

(Note): To simplify the displays, only the lower four digits (Hex) of each error code are displayed in the above table.

●: Recoverable, -: Unrecoverable

Error code	Error name	Description	Object	Recovered	Countermeasures
3046H	Movement automatic check value error	The difference between the command value and feedback value exceeded the movement automatic check threshold value with the movement automatic check function.	Each axis	●	Check the operation of the target axes. Check the parameter of the movement amount automatic check function.
3050H	Torque judgment error	The torque value exceeds the setting torque monitor judgement value.	Each axis	●	- Design the system within the range that the torque of the motor does not exceed the judgment value. - Check the torque monitor judgment value.
3051H	Actual speed judgment value error	The actual speed exceeds the setting actual speed monitor judgement value.	Each axis	●	- Design the system within the range that the actual speed of the motor does not exceed the judgment value. - Check the actual speed monitor judgment value.
3060H	Home return not executable error	The home return could not be executed as AMP parameter settings and signal input were not correct.	Each axis	●	Check the parameters of AMP and signal inputs.

(Note): To simplify the displays, only the lower four digits (Hex) of each error code are displayed in the above table.

### 15.3.5 Setting Value Errors (From 00F0 4000H)

These are the errors in the various setting values specified using the positioning setting menu of the programming tool or ladder programs.

●: Recoverable, -: Unrecoverable

Error code	Error name	Description	Object	Recovered	Countermeasures
4000H	Axis group setting error	The settings of axis groups are not correct.	Each axis	●	Check the following items in the settings of the axis group and independent axis. - The same axis number has been registered in more than one group. - Four or more axes have been set in one group. - The group is composed of one axis only.
4002H	Unit setting error	The unit system for the axis setting is out of the range.	Each axis	●	Check if the unit is one of the followings. pulse, μm, inch, degree
4004H	Pulse number per revolution error	The number of pulses is out of the range.	Each axis	●	Check the set value. If the setting value is out of the range, reduce it by the following formula. (Pulse number per rotation) / (Movement amount per rotation)
4005H	Movement per revolution error	The movement amount is out of the range.	Each axis	●	
4010H	Software limit setting error	The upper or lower limit value of software limit is out of the range.	Each axis	●	Check the set value. If the error occurs repeatedly with the correct set values, consult your Panasonic representative.
4011H	Positioning completion width check time error	The completion width check time is out of the range.	Each axis	●	
4012H	Positioning completion width error	The completion width is out of the range.	Each axis	●	
4020H	Limit stop deceleration time error	The limit stop deceleration time is out of the range.	Each axis	●	
4021H	Error stop deceleration time error	The error stop deceleration time is out of the range.	Each axis	●	
4022H	Emergency stop deceleration time error	The emergency stop deceleration time is out of the range.	Each axis	●	

(Note): To simplify the displays, only the lower four digits (Hex) of each error code are displayed in the above table.

## 15.3 Error Code Table

●: Recoverable, -: Unrecoverable

Error code	Error name	Description	Object	Recovered	Countermeasures
4028H	Auxiliary output setting error	The settings of auxiliary output are not correct. A mode other than With mode or Delay mode has been set for the auxiliary output mode. The auxiliary output delay ratio of Delay mode is not in the range of 0 to 100 (%).	Each axis	●	Check the set value. If the error occurs repeatedly with the correct set values, consult your Panasonic representative.
4030H	Synchronous group setting error	Either master axis or slave axis has not been set. Multiple master axes or slave axes have been set. The same axis has been set for the master and slave axes. A virtual axis has been set to a slave axis.	Each axis	●	
4041H	Completion width error	Completion width is out of the range.	Each axis	●	
4044H	Speed rate error	The setting of the speed rate is out of the range.	Each axis	●	
4080H	JOG positioning acceleration/deceleration type error	The acceleration/deceleration method of the JOG positioning is out of the range.	Each axis	●	
4081H	JOG positioning operation acceleration time error	The acceleration time of the JOG positioning is out of the range.	Each axis	●	
4082H	JOG positioning operation deceleration time error	The deceleration time of the JOG positioning is out of the range.	Each axis	●	
4083H	JOG positioning operation target speed error	The target speed of the JOG positioning is out of the range.	Each axis	●	
4102H	Home return target speed error	The target speed of the home return is out of the range.	Each axis	●	
4105H	Home return acceleration time error	The acceleration time of the home return is out of the range.	Each axis	●	
4106H	Home return deceleration time error	The deceleration time of the home return is out of the range.	Each axis	●	
4107H	Home return setting code error	The home return setting code is incorrect.	Each axis	●	
4110H	Home return creep speed error	The creep speed of the home return is out of the range.	Each axis	●	

(Note): To simplify the displays, only the lower four digits (Hex) of each error code are displayed in the above table.

## Troubleshooting

●: Recoverable, -: Unrecoverable

Error code	Error name	Description	Object	Recovered	Countermeasures
4111H	Home return direction error	The moving direction of the home return is out of the range.	Each axis	●	Check the set value. If the error occurs repeatedly with the correct set values, consult your Panasonic representative.
4112H	Home return limit error	The limit switch is disabled. (It occurs when the home return method is set to the stop-on-contact method 1 or 2.)	Each axis	●	
4115H	Home return stop-on-contact torque value error	The home return stop-on-contact torque value is out of the range. (It occurs when the home return method is set to the stop-on-contact method 1 or 2.)	Each axis	●	
4116H	Home return stop-on-contact judgment time error	The home return stop-on-contact judgment time is out of the range. (It occurs when the home return method is set to the stop-on-contact method 1 or 2.)	Each axis	●	
4120H	Home coordinate error	The set home coordinates are out of the range.	Each axis	●	
4201H	JOG operation target speed error	The target speed of the JOG operation is out of the range.	Each axis	●	
4203H	JOG operation acceleration/ deceleration type error	The acceleration/deceleration type of the JOG operation is incorrect.	Each axis	●	
4204H	JOG operation acceleration time error	The acceleration time of the JOG operation is out of the range.	Each axis	●	
4205H	JOG operation deceleration time error	The deceleration time of the JOG operation is out of the range.	Each axis	●	
4206H	Inching movement amount error	The inching movement amount is out of the range.	Each axis	●	
4250H	Current value update error	The setting value of the current value update coordinate is out of the range.	Each axis	●	
4251H	Real time torque limit value error	The set torque limit value is out of the range.	Each axis	●	

(Note): To simplify the displays, only the lower four digits (Hex) of each error code are displayed in the above table.

## 15.3 Error Code Table

●: Recoverable, -: Unrecoverable

Error code	Error name	Description	Object	Recovered	Countermeasures
4301H	Absolute/increment setting error	A value other than the absolute/increment is set for the move method.	Each axis	●	Check the set value. If the error occurs repeatedly with the correct set values, consult your Panasonic representative.
4302H	Dwell time error	The setting value of the dwell time is out of the range.	Each axis	●	
4303H	Positioning starting table no. error	The specified table number is 0, or it exceeds the maximum table number.	Each axis	●	
4304H	Table setting error	The last table of the positioning setting tables is not point E.	Each axis	●	
4305H	J-point control repetition error	J-point control cannot be repeated. J-point control cannot be executed multiple times in a row.	Each axis	●	
4400H	Positioning movement amount setting error	The movement amount of the positioning operation is out of the range.	Each axis	●	
4401H	Positioning acceleration/deceleration type error	The acceleration/deceleration type of the positioning operation is incorrect.	Each axis	●	
4402H	Positioning acceleration time error	The acceleration time of the positioning operation is out of the range.	Each axis	●	
4403H	Positioning deceleration time error	The deceleration time of the positioning operation is out of the range.	Each axis	●	
4404H	Positioning target speed error	The target speed of the positioning operation is out of the range.	Each axis	●	
4500H	Interpolation type error	The setting of the interpolation type is incorrect.	Each axis	●	
4504H	Circular interpolation not executable	The parameter of the circular interpolation (such as center point or pass point) is incorrect.	Each axis	●	
4505H	Spiral interpolation not executable	The error occurred during the spiral interpolation as the setting value is incorrect.	Each axis	●	
4510H	Target speed change function speed value error	The changed speed value is out of the range.	Each axis	●	
4520H	The changed movement amount is out of the range.	The changed movement amount of positioning movement amount change is out of the range.	Each axis	●	
4609H	Movement automatic check operation method setting error	The setting for the operation of movement automatic check function is incorrect.	Each axis	●	

(Note): To simplify the displays, only the lower four digits (Hex) of each error code are displayed in the above table.

### 15.3.6 Synchronous Parameter Setting Errors (From 00F0 5000H)

■ Synchronous parameter: Common errors

●: Recoverable, -: Unrecoverable

Error code	Error name	Description	Object	Recovered	Countermeasures
5000H	Synchronous master setting value error	The setting for the synchronous master axis is incorrect. - Setting error (Value is incorrect.) - Own axis setting	Each axis	●	Check the set value. If the error occurs repeatedly with the correct set values, please contact us.
5002H	Synchronous setting disable error	The synchronous setting request was made in the following axis setting. - Its own axis (slave axis) is set as the master of another axis. - The master axis is set as the slave axis of another axis. - Its own axis (slave axis) belongs to the interpolation group.	Each axis	●	
5006H	Synchronous slave single deceleration stop deceleration time	The setting for the synchronous slave single deceleration stop time is incorrect.	Each axis	●	

(Note): To simplify the displays, only the lower four digits (Hex) of each error code are displayed in the above table.

■ Synchronous parameter: Electronic gear related errors

●: Recoverable, -: Unrecoverable

Error code	Error name	Description	Object	Recovered	Countermeasures
5100H	Electronic gear - Gear ratio numerator setting error	The setting for the gear ratio numerator of the electronic gear is incorrect.	Each axis	●	Check the set value. If the error occurs repeatedly with the correct set values, please contact us.
5101H	Electronic gear - Gear ratio denominator setting error	The setting for the gear ratio denominator of the electronic gear is incorrect.	Each axis	●	
5102H	Electronic gear- Gear ratio change time setting error	The setting for the gear ratio change time of the electronic gear is incorrect.	Each axis	●	

(Note): To simplify the displays, only the lower four digits (Hex) of each error code are displayed in the above table.



### ■ Synchronous parameter: Electronic clutch related errors

●: Recoverable, -: Unrecoverable

Error code	Error name	Description	Object	Recovered	Countermeasures
5200H	Electronic clutch - Clutch ON trigger type setting error	The setting for the clutch ON trigger type is incorrect.	Each axis	●	Check the set value. If the error occurs repeatedly with the correct set values, please contact us.
5201H	Electronic clutch - Clutch ON edge selection setting error	The setting for the clutch ON edge selection is incorrect.	Each axis	●	
5203H	Electronic clutch - Clutch OFF trigger type setting error	The setting for the clutch OFF trigger type is incorrect.	Each axis	●	
5204H	Electronic clutch - Clutch OFF edge selection setting error	The setting for the clutch OFF edge selection is incorrect.	Each axis	●	
5205H	Phase specification clutch off function setting error	"I/O + Phase after clutch control clutch OFF" was selected for the clutch OFF trigger type when an electronic cam is not used.	Each axis	●	When selecting "I/O + Phase after clutch control" for the clutch OFF trigger type, set the electronic cam to "Use".
5206H	Phase specification clutch off function phase value setting error	The phase value setting is incorrect.	Each axis	●	Check the set value. If the error occurs repeatedly with the correct set values, please contact us.
5207H	Electronic clutch - Clutch ON method setting error	The setting for the clutch ON method is incorrect.	Each axis	●	
5208H	Electronic clutch - Clutch ON slip method setting error	The setting for the clutch ON slip method is incorrect.	Each axis	●	
5209H	Electronic clutch - Clutch ON slip time setting error	The setting for the clutch ON slip time is incorrect.	Each axis	●	
5210H	Electronic clutch - Clutch ON slip curve selection setting error	The setting for the clutch ON slip curve is incorrect.	Each axis	●	
5211H	Electronic clutch - Clutch OFF method setting error	The setting for the clutch OFF method is incorrect.	Each axis	●	
5212H	Electronic clutch - Clutch OFF slip method setting error	The setting for the clutch OFF slip method is incorrect.	Each axis	●	
5213H	Electronic clutch - Clutch OFF slip time setting error	The setting for the clutch OFF slip time is incorrect.	Each axis	●	
5214H	Electronic clutch - Clutch OFF slip curve selection setting error	The setting for the clutch OFF slip curve is incorrect.	Each axis	●	

(Note): To simplify the displays, only the lower four digits (Hex) of each error code are displayed in the above table.

## Troubleshooting

### ■ Synchronous parameter: Electronic cam related errors

●: Recoverable, -: Unrecoverable

Error code	Error name	Description	Object	Recovered	Countermeasures
5300H	Electronic cam - Cam control synchronous master axis cycle setting error	The setting for the cam control synchronous master axis cycle is incorrect.	Each axis	●	Check the set value. If the error occurs repeatedly with the correct set values, please contact us.
5301H	Electronic cam - Used cam pattern no. setting error	The used cam pattern number is out of the range. The used cam pattern number is not registered.	Each axis	●	
5302H	Electronic cam - Cam stroke amount setting error	The setting for the cam stroke amount is incorrect.	Each axis	●	
5310H	Advance angle correction function / Reference amount setting error	The advance angle correction reference amount setting is incorrect.	Each axis	●	
5311H	Advance angle correction function / Reference speed setting	The advance angle correction reference speed setting is incorrect.	Each axis	●	
5312H	Advance angle correction function / Parameter change time error	Advance angle correction parameter change time setting is incorrect	Each axis	●	

(Note): To simplify the displays, only the lower four digits (Hex) of each error code are displayed in the above table.

### ■ Cam pattern related errors

●: Recoverable, -: Unrecoverable

Error code	Error name	Description	Object	Recovered	Countermeasures
5400H	Cam pattern resolution setting error	The setting for the cam pattern resolution is out of the range.	Each axis	●	Check the set value. If the error occurs repeatedly with the correct set values, please contact us.
5401H	Cam pattern set number setting error	The cam pattern set number is out of the range.	Each axis	●	
5402H	Cam pattern section function setting error	The setting for the cam pattern section function is out of the range.	Each axis	●	
5403H	Cam pattern control start position setting error	The setting for the cam pattern control start position is out of the range.	Each axis	●	
5404H	Cam pattern start phase setting error	The start phase setting for each section of cam pattern is out of the range.	Each axis	●	
5405H	Cam pattern displacement setting error	The displacement for each section of cam pattern is out of the range.	Each axis	●	
5406H	Cam pattern cam curve no. setting error	The curve number for each section of cam pattern is out of the range.	Each axis	●	
5410H	Adjustment data total no. setting error	The total number of cam pattern adjustment data is out of the range.	Each axis	●	
5411H	Adjustment data no. setting error	The number of cam pattern adjustment data is out of the range. (cam pattern unit)	Each axis	●	
5413H	Adjustment data control point setting error	The control point of cam pattern adjustment data is out of the range.	Each axis	●	
5414H	Out-of-range adjustment data setting error	The adjustment value of cam pattern adjustment data is out of the range.	Each axis	●	

(Note): To simplify the displays, only the lower four digits (Hex) of each error code are displayed in the above table.

### 15.3.7 Other Errors (From 00F0 F000H)

Other Errors.

Error code	Error name	Description	Object	Recovered	Countermeasures
F000H	Servo amplifier homing error	A homing error (bit 13 of CoE object "6041H_00H") occurred on the servo amplifier side when home return operation was performed.	Each axis	●	Refer to "Homing error occurrence conditions" in the Servo Amplifier Specification.

## 15.4 Warning Code Table

---

### 15.4.1 AMP Warnings (From 00A0 0000H)

---

- Warnings occurred on the AMP side are output from FP7 MC Unit as warning codes.
- The AMP warnings differ depending on the types of AMP. For details of the processing for AMP warnings, refer to the manual of servo amplifiers.

■ AMP warning code table [For A6B]

FP7 MC Warning code	A6B warning no.	Description
00A0	A0	Overload warning
00A1	A1	Over-regeneration warning
00A2	A2	Battery warning
00A3	A3	Fan warning
00A4	A4	Encoder communication warning
00A5	A5	Encoder overheat warning
00A6	A6	Oscillation detection warning
00A7	A7	Lifetime detection warning
00A8	A8	External scale error warning
00A9	A9	External scale communication warning
00AC	AC	Deterioration diagnosis warning
00C3	C3	Main power off warning
00D2	D2	PANATERM command execution warning

(Note): Refer to the latest instruction manual and technical materials of the servo amplifier.

## ■ AMP warning code table [For A5B]

FP7 MC Warning code	A5B warning no.	Description
00A0	A0	Overload protection
00A1	A1	Over-regeneration alarm
00A2	A2	Battery alarm
00A3	A3	Fan alarm
00A4	A4	Encoder communication alarm
00A5	A5	Encoder overheat alarm
00A6	A6	Oscillation detection warning
00A7	A7	Lifetime detection alarm
00A8	A8	External scale error warning (Not supported)
00A9	A9	External scale communication warning (Not supported)
00C3	C3	Main power off warning

(Note): Refer to the latest instruction manual and technical materials of the servo amplifier.

**15.4.2 Unit Warnings (From 00B0 0000H)**

These are the warning codes to be given when the warnings occurred in the unit.

●: Recoverable, -: Unrecoverable

Warning code	Warning name	Description	Object	Recovered	Countermeasures
0000H	Tool operation	The following request flags turned on by the host PLC during the tool operation. - Positioning start request flag (each axis) - Home return request flag (each axis) - JOG operation forward/reverse request flag (each axis)	Each axis	●	Various requests cannot be executed from the PLC during the tool operation. However, the following requests can be executed from the PLC during the tool operation. - System stop request flag (all axes) - Emergency stop request flag (each axis) - Deceleration stop request flag (each axis)
0004H	Real time speed limit protection	The real time torque limit was not executed as the AMP parameter operation or AMP monitor operation was being executed.	Each axis	●	Execute the real time torque limit when the AMP parameter operation and AMP monitor are not used.
0008H	SD memory card warning	The SD memory card access error occurred.	All axes	●	Check if an SD memory card is inserted correctly.
0010H	Duplicate startup	The same axis was requested to start even though the axis operation has not completed.	Each axis	●	The requests for the axes being operated cannot be executed, except the following requests. - System stop request flag (all axes) - Emergency stop request flag (each axis) - Deceleration stop request flag (each axis)
0030H	J-point simultaneous startup warning	“J-point speed change request” and J-point positioning start request” turned on simultaneously during the JOG positioning operation. The J-point speed change request turned on during acceleration/deceleration.	Each axis	●	When the both requests have been turned on simultaneously, “J-point positioning start request” has a priority, and “J-point speed change request” is ignored. Please program to turn on the J-point speed change request during turned on during the constant speed control.
0031H	J-point speed change request warning	The J-point speed change request turned on when J-point operation is not active.	Each axis	●	Check the timing that the J-point speed change request turns on.
0032H	J-point positioning start request warning	The J-point positioning start request turned on when J-point operation is not active.	Each axis	●	Check the timing that the J-point positioning change request turns on.
0046H	Movement automatic check warning	The difference between the command value and feedback value exceeded the specified movement automatic check value with the movement automatic check function. This warning occurs when setting the movement automatic check operation to "Warning".	Each axis	●	Check the operation of the target axes.

(Note): To simplify the displays, only the lower four digits (Hex) of each error code are displayed in the above table.

## 15.4 Warning Code Table

●: Recoverable, -: Unrecoverable

Warning code	Warning name	Description	Object	Recovered	Countermeasures
0050H	Torque judgment warning	The torque value exceeds the setting torque monitor judgement value.	Each axis	●	- Design the system within the range that the torque of the motor does not exceed the judgment value. - Check the torque monitor judgment value.
0051H	Actual speed judgment value warning	The actual speed exceeds the setting actual speed monitor judgement value.	Each axis	●	- Design the system within the range that the actual speed of the motor does not exceed the judgment value. - Check the actual speed monitor judgement value.
0060H	Target speed change function disable warning (except positioning)	The speed change request turned on when the positioning operation was not performed.	Each axis	●	Check the timing that the speed change request contact turns on.
0062H	Target speed change function disable warning (J-point control active)	The speed change request turned on during the J-point operation.	Each axis	●	
0063H	Target speed change function disable warning (Synchronous slave axis specified)	The speed change request contact of synchronous slave axis turned on	Each axis	●	
0064H	Target speed change function disable warning (positioning done)	The speed change request contact turned on in the state that the positioning output is complete.	Each axis	●	
0065H	Target speed change function disable warning (During positioning stop process)	The speed change request contact turned on when any positioning stop processing is performed.	Each axis	●	
0066H	Target speed change function disable warning (During dwell process)	The speed change request contact turned on when the positioning dwell processing is performed.	Each axis	●	

(Note): To simplify the displays, only the lower four digits (Hex) of each error code are displayed in the above table.

## Troubleshooting

●: Recoverable, -: Unrecoverable

Warning code	Warning name	Description	Object	Recovered	Countermeasures
0070H	Movement amount change function disable warning (except positioning)	The movement amount change request contact turned on when the positioning operation was not performed.	Each axis	●	Check the timing that the movement amount change request contact turns on.
0071H	Movement amount change function disable warning (interpolation operation active)	The movement amount change request contact turned on during the interpolation operation.	Each axis	●	
0072H	Movement amount change function disable warning (J-point control active)	The movement amount change request turned on during the J-point operation.	Each axis	●	
0073H	Movement amount change function disable warning (Synchronous slave axis specified)	The movement amount change request contact of synchronous slave axis turned on.	Each axis	●	
0074H	Movement amount change function disable warning (Positioning done)	The movement amount change request contact turned on in the state that the positioning output is complete.	Each axis	●	
0075H	Movement amount change function disable warning (During positioning stop process)	The movement amount change request contact turned on when any positioning stop processing is performed.	Each axis	●	
0076H	Movement amount change function disable warning (During dwell process)	The movement amount change request contact turned on when the positioning dwell processing is performed.	Each axis	●	
0100H	Synchronous setting change disable warning	The change of the synchronous setting was requested on an operating axis.	Each axis	●	Changing the synchronous setting should be performed when the busy flag for the axes to be synchronized is off.
0110H	Cam pattern table reading warning	The operation for the cam pattern table reading request ended abnormally as an incorrect value was set or the execution condition was not satisfied.	All axes	●	<ul style="list-style-type: none"> <li>- Confirm the setting values of the parameters required for reading cam patterns.</li> <li>- Confirm if any axes are in synchronous operation. If any, cancel the synchronous operation and read the cam pattern tables.</li> <li>* The details about the cause of the occurrence of this warning are stored in the "cam pattern reading result" area of unit memories.</li> </ul>

(Note): To simplify the displays, only the lower four digits (Hex) of each warning code are displayed in the above table.



## 15.4 Warning Code Table

●: Recoverable, -: Unrecoverable

Warning code	Warning name	Description	Object	Recovered	Countermeasures
0111H	Cam pattern table over-writing warning	The operation for the cam pattern table rewriting request ended abnormally as an incorrect value was set or the execution condition was not satisfied.	All axes	●	<ul style="list-style-type: none"> <li>- Confirm the setting values of the parameters required for rewriting cam patterns.</li> <li>- Confirm if any axes are in synchronous operation. If any, cancel the synchronous operation and rewrite the cam pattern tables.</li> <li>* The details about the cause of the occurrence of this warning are stored in the "cam pattern rewriting result" area of unit memories.</li> </ul>
0120H	Trigger setting warning	The trigger condition setting error occurred.	All axes	●	Check that the trigger conditions are set correctly.
0121H	Tool logging function enable warning	When UM02613 is on (logging enabled), it is detected that YB is on.	All axes	●	After setting UM02613 to off, turn on the YB (logging enabled).
0300H	Control area for buffer control value warning	<p>The following parameters of the control area for buffer control is out of the range.</p> <ul style="list-style-type: none"> <li>- Request flag control</li> <li>- Request code control</li> <li>- Response code control</li> <li>- Axis number control</li> <li>- Starting table number</li> <li>- Table size</li> <li>- Extended positioning table usage setting</li> <li>- Extended positioning table usage setting corresponding axis no.</li> </ul>	All axes /Each axis	●	<ul style="list-style-type: none"> <li>- Confirm the setting values of the parameters for control area for buffer control.</li> </ul>
0304H	Recalculation error warning	An error occurred when recalculation was performed.	Each axis	●	Even when the error occurred, recalculation process in which no error occurs is executed. Check the settings and execute the recalculation process again.

(Note): To simplify the displays, only the lower four digits (Hex) of each warning code are displayed in the above table.



# 16

## Specifications

## 16.1 Specifications

---

### 16.1.1 General Specifications

---

Item	Description
Operating ambient temperature	0 to +55 °C
Storage ambient temperature	-40 to +70 °C
Operating ambient humidity	10 to 95%RH (at 25 °C with no-condensing)
Storage ambient humidity	10 to 95%RH (at 25 °C with no-condensing)
Breakdown voltage	Each external connector pin and entire power supply terminals of CPU unit 500 V AC for 1 minute
Insulation resistance	Each external connector pin and entire power supply terminals of CPU unit 100 MΩ min. (at 500 V DC)
Vibration resistance	Conforming to JIS B 3502 and IEC 61131-2 5 to 8.4 Hz, 3.5 mm single amplitude 8.4 to 150 Hz, acceleration of 9.8 m/s <sup>2</sup> 10 sweeps each in X, Y and Z directions (1 octave/min)
Shock resistance	Conforming to JIS B 3502 and IEC 61131-2 147 m/s <sup>2</sup> min. in X, Y, and Z directions three times each
Noise resistance	1,000 V [P-P], pulse width of 50 ns/1 μs (by noise simulator)
Environment	Free from corrosive gases and excessive dust.
EU Directive applicable standard	EMC directive: EN 61131-2
Overvoltage category	Category II
Pollution degree	Pollution degree 2
Internal current consumption	180 mA or less
Weight	Approx. 150 g

## 16.1.2 EtherCAT Communication Specifications

### ■ Performance Specifications

Item	Description
Communication protocol	EtherCAT dedicated protocol
Support service	CoE (PDO communication, SDO communication)
Simultaneous communication	DC (Distributed clock)
Communication standard	IEC 61158 Type12
Modulation method	Baseband
Physical layer	100BASE-TX (IEEE802.3)
Baud rate	100M bps
Duplex mode	Auto
Transmission distance	Max. distance between nodes: 100 m
Topology	Daisy chain (without branch)
Applicable cable	Shielded twisted-pair cable (Category 5e or higher)
Connector	9-pin RJ45 x 1
Communication cycle	0.5 ms / 1 ms / 2 ms / 4 ms
Connected slave (Note 1) (Note 2) (Note 3)	Panasonic AC Servo Motor A6B/A5B series S-LINK V Gateway Controller EtherCAT-compatible SL-VGU1-EC series EtherCAT-compatible Communication Unit for Digital Sensor SC-GU3-03 series
No. of connected slaves (Note 4)	AFP7MC16EC: 1 to 144 (Servo/Encoder: Max. 16, Others: 128) AFP7MC32EC: 1 to 160 (Servo/Encoder: Max. 32, Others: 128) AFP7MC64EC: 1 to 192 (Servo/Encoder: Max. 64, Others: 128)

(Note 1): The A6B series and SL-VGU1-EC series are available since the FP7 MC Unit Ver.1.2. The Communication Unit for Digital Sensor SC-GU3-03 series will be available in the near future.

(Note 2): More than one A6B or A5B should exist on a network. Also, the mixed connection of A6B and A5B can be used.

(Note 3): Hubs for EtherCAT and Ethernet cannot be used.

(Note 4): As for Encoder, only the operation of the encoder input terminal GX-EC0211 made by Omron Corporation has been confirmed.

### ■ Function Specifications

Item	Description
Synchronous mode	Free RUN mode (Asynchronous): Digital I/O slave, Analog I/O slave DC (Distributed clock): Encoder input slave
Process data communication (PDO communication)	PDO mapping by CoE Max. number of data: IN: 5,936 bytes (2968 words), OUT: 5,936 bytes (2968 words)
Mail box communication (SDO communication)	CoE - Emergency message (Received from slave devices) - SDO request, SDO response, SDO information Max. number of data: 2,048 bytes (1024 words)

(Note): The SDO communication and PDO communication by user programs are available since FP7 MC Unit Ver.1.2.

16.1.3 Performance Specifications

Item		Description			
		16-axis type	32-axis type	64-axis type	
		AFP7MC16EC	AFP7MC32EC	AFP7MC64EC	
No. of control axes		Real axis: 16 axes Virtual axis: 8 axes	Real axis: 32 axes Virtual axis: 16 axes	Real axis: 64 axes Virtual axis: 32 axes	
Interpolation control		2-axis linear interpolation, 2-axis circular interpolation, 3-axis linear interpolation, 3-axis spiral interpolation			
No. of occupied inputs/outputs		Input: 16 points, Output: 16 points			
Automatic operation	Positioning control CSP	Position specification method		Absolute (specified absolute position), Increment (specified relative position)	
		Position specified unit		pulse μm (select a minimum instruction unit of 0.1 μm or 1 μm) inch (select a minimum instruction unit of 0.00001 inch or 0.0001 inch) degree (select a minimum instruction unit of 0.1 degree or 1 degree)	
		Position reference range		pulse: -2,147,483,648 to +2,147,483,647 pulses μm (0.1 μm): -214,748,364.8 to +214,748,364.7 μm μm (1 μm): -2,147,483,648 to +2,147,483,647 μm inch (0.00001 inch): -21,474.83648 to +21,474.83647 inches inch (0.0001 inch): -214,748.3648 to +214,748.3647 inches degree (0.1 degree): -214,748,364.8 to +214,748,364.7 degrees degree (1 degree): -2,147,483,648 to +2,147,483,647 degrees	
		Speed reference range		pulse: 1 to 2,147,483,647 pps μm: 1 to 2,147,483,647 μm/s inch: 0.001 to 2,147,483.647 inch/s degree: 0.001 to 2,147,483.647 rev/s	
		Acceleration/deceleration type		Linear acceleration/deceleration S-shaped acceleration/deceleration	
		Acceleration time		0 to 10,000 ms (adjustable in 1 ms increments)	
		Deceleration time		0 to 10,000 ms (adjustable in 1 ms increments)	
		No. of positioning tables		Each axis: Standard area: 1,000 points Expansion area: 100 points (* However, the axes simultaneously used are 24 axes.)	
	Control method	Independent		PTP control (E-point and C-point control) CP control (P-point control) JOG positioning control (J-point control)	
		2-axis interpolation	Linear interpolation	E-point, P-point, C-point control; composite speed or long axis speed specification	
			Circular interpolation	E-point, P-point, C-point control; center point or pass point specification	
		3-axis interpolation	Linear interpolation	E-point, P-point, C-point control; composite speed or long axis speed specification	
	Spiral interpolation		E-point, P-point, C-point control; center point or pass point specification		

Item			Description				
			16-axis type		32-axis type		64-axis type
			AFP7MC16EC		AFP7MC32EC		AFP7MC64EC
Automatic operation	Positioning control CSP	Other functions	Dwell time	0 to 32,767 ms (settable by 1 ms)			
			Auxiliary output code	Output as auxiliary output codes in the axis information area.			
			Auxiliary output contact	With mode: Auxiliary output ON time: 0 to 255 ms Delay mode: Auxiliary output ON time: 0 to 255 ms / Delay ratio: 0 to 100%			
			Changing the speed during JOG operation	pulse: 1 to 2,147,483,647 pps $\mu$ m: 1 to 2,147,483,647 $\mu$ m/s inch: 0.001 to 2,147,483.647 inch/s degree: 0.001 to 2,147,483.647 rev/s			
			Movement amount change during operation	pulse: -2,147,483,648 to +2,147,483,647 pulses $\mu$ m (0.1 $\mu$ m): -214,748,364.8 to +214,748,364.7 $\mu$ m $\mu$ m (1 $\mu$ m): -2,147,483,648 to +2,147,483,647 $\mu$ m inch (0.00001 inch): -21,474.83648 to +21,474.83647 inches inch (0.0001 inch): -214,748.3648 to +214,748.3647 inches degree (0.1 degree): -214,748,364.8 to +214,748,364.7 degrees degree (1 degree): -2,147,483,648 to +2,147,483,647 degrees			
			Repeat function	2 to 244 times Repeat unlimitedly			
Synchronous operation function	Synchronous basic setting	Master axis	Selectable from real axes, virtual axes and pulse inputs.				
		Slave axis	Max. 8 axes/master	Max. 16 axes/master	Max. 32 axes/master		
		Deceleration stop deceleration method	Linear acceleration/deceleration S-shaped acceleration/deceleration				
	Electronic gear	Operation setting	Gear ratio setting Gear ratio numerator: 1 to 2,147,483,647 Gear ratio denominator: 1 to 2,147,483,647				
		Gear ratio change time	0 to 10,000 ms (adjustable in 1 ms increments)				
		Operation method	Direct method, acceleration/deceleration method				
	Electronic clutch	Clutch ON trigger	Contact input				
		Clutch OFF trigger	Contact input, Phase judgement (Phase ratio 0 to 99%)				
		Clutch method	Direct method, linear slide method				
		Clutch slip time	1 to 10,000 ms (adjustable in 1 ms increments)				
	Electronic cam	Cam curve	Select from 20 types Multiple curves can be specified within phase (0 to 100%)				
		Resolution	1024, 2048, 4096, 8192, 16384, 32768				
		No. of cam patterns	16 to 64 (According to resolution)	32 to 128 (According to resolution)	64 to 256 (According to resolution)		
		Master axis cycle	1 to 2,147,483,647				
		Cam stroke amount	1 to 2,147,483,647				
		Advance angle correction reference amount	pulse: -2,147,483,648 to +2,147,483,647 pulses $\mu$ m (0.1 $\mu$ m): -214,748,364.8 to +214,748,364.7 $\mu$ m $\mu$ m (1 $\mu$ m): -2,147,483,648 to +2,147,483,647 $\mu$ m inch (0.00001 inch): -21,474.83648 to +21,474.83647 inches inch (0.0001 inch): -214,748.3648 to +214,748.3647 inches degree (0.1 degree): -214,748,364.8 to +214,748,364.7 degrees degree (1 degree): -2,147,483,648 to +2,147,483,647 degrees				
Advance angle correction reference speed		pulse: 1 to 2,147,483,647 pps $\mu$ m: 1 to 2,147,483,647 $\mu$ m/s inch: 0.001 to 2,147,483.647 inch/s degree: 0.001 to 2,147,483.647 rev/s					

## Specifications

Item			Description		
			16-axis type	32-axis type	64-axis type
			AFP7MC16EC	AFP7MC32EC	AFP7MC64EC
Manual operation	JOG/Inching operation	Speed reference range	pulse: 1 to 2,147,483,647 pps µm: 1 to 2,147,483,647 µm/s inch: 0.001 to 2,147,483.647 inch/s degree: 0.001 to 2,147,483.647 rev/s		
		Acceleration/ deceleration type	Linear acceleration/deceleration S-shaped acceleration/deceleration		
		Acceleration time	0 to 10,000 ms (adjustable in 1 ms increments)		
		Deceleration time	0 to 10,000 ms (adjustable in 1 ms increments)		
		Inching movement	pulse: 1 to 2,147,483,647 pulses µm (0.1 µm): 0.1 to 214748364.7 µm µm (1 µm): 1 to 2,147,483,647 µm inch (0.00001 inch): 0.00001 to 21,474.83647 inch inch (0.0001 inch): 0.0001 to 214,748.3647 inch degree (0.1 degree): 0.1 to 214,748,364.7 degrees degree (1 degree): 1 to 2,147,483,647 degrees		
	Home Return	Speed reference range (Target speed/Creep speed)	pulse: 1 to 2,147,483,647 pps µm: 1 to 2,147,483,647 µm/s inch: 0.001 to 2,147,483.647 inch/s degree: 0.001 to 2,147,483.647 rev/s		
		Acceleration/ deceleration type	Linear acceleration/deceleration, S-shaped acceleration/deceleration		
		Acceleration time	0 to 10,000 ms (adjustable in 1 ms increments)		
		Deceleration time	0 to 10,000 ms (adjustable in 1 ms increments)		
		Return method	DOG method (4 types), Limit method (2 types), Z phase method, Stop-on-contact method (2 types), Data set method		
		Stop-on-contact torque value	0 to 500.0% (adjustable in 0.1% increments.)		
		Stop-on-contact judgment time	0 to 10,000 ms (adjustable in 1 ms increments)		
	Home coordinates (Home offset)	pulse: -2,147,483,648 to +2,147,483,647 pulses µm (0.1 µm): -214,748,364.8 to +214,748,364.7 µm µm (1 µm): -2,147,483,648 to +2,147,483,647 µm inch (0.00001 inch): -21,474.83648 to +21,474.83647 inches inch (0.0001 inch): -214,748.3648 to +214,748.3647 inches degree (0.1 degree): -214,748,364.8 to +214,748,364.7 degrees degree (1 degree): -2,147,483,648 to +2,147,483,647 degrees			
	Stop function	System stop	Deceleration time	Immediate stop (0 ms) (All axes stop)	
Limit stop		Deceleration time	0 to 10,000 ms (adjustable in 1 ms increments)		
Error stop		Deceleration time	0 to 10,000 ms (adjustable in 1 ms increments)		
Emergency stop		Deceleration time	0 to 10,000 ms (adjustable in 1 ms increments)		
Deceleration stop		Deceleration time	Depends on the deceleration time set for the running operation.		
Memory Backup			The data of communication parameters, positioning parameters and positioning tables is saved in the FROM within FP7 MC Unit (without battery). Guaranteed number of times of writing: Up to 10000 times		



Item			Description		
			16-axis type	32-axis type	64-axis type
			AFP7MC16EC	AFP7MC32EC	AFP7MC64EC
Other functions	Software limit function	Setting range	pulse: -2,147,483,648 to +2,147,483,647 pulses $\mu\text{m}$ (0.1 $\mu\text{m}$ ): -214,748,364.8 to +214,748,364.7 $\mu\text{m}$ $\mu\text{m}$ (1 $\mu\text{m}$ ): -2,147,483,648 to +2,147,483,647 $\mu\text{m}$ inch (0.00001 inch): -21,474.83648 to +21,474.83647 inches inch (0.0001 inch): -214,748.3648 to +214,748.3647 inches degree (0.1 degree): -214,748,364.8 to +214,748,364.7 degrees degree (1 degree): -2,147,483,648 to +2,147,483,647 degrees		
	Speed rate function		0 to 500 (%) (For single axis control) 0 to 200 (%) (For interpolation control)		
	Current Value Update Function		pulse: -2,147,483,648 to +2,147,483,647 pulses $\mu\text{m}$ (0.1 $\mu\text{m}$ ): -214,748,364.8 to +214,748,364.7 $\mu\text{m}$ $\mu\text{m}$ (1 $\mu\text{m}$ ): -2,147,483,648 to +2,147,483,647 $\mu\text{m}$ inch (0.00001 inch): -21,474.83648 to +21,474.83647 inches inch (0.0001 inch): -214,748.3648 to +214,748.3647 inches degree (0.1 degree): -214,748,364.8 to +214,748,364.7 degrees degree (1 degree): -2,147,483,648 to +2,147,483,647 degrees		
	Setting data		Depends on the control unit.		
	General-purpose input: 5 points, General-purpose input: 1 point (Input and output from AMP), Torque monitor, Real speed monitor (Note 1)				

(Note 1): Two points out of five general-purpose inputs are used as limit inputs.

## 16.2 I/O Allocation

### ■ Allocation of I/O Numbers (Input)

I/O no.	Target axis	Name	Description
X0	All axes	Link establishment	Announces the establishment of the network link. ON: Link is established, OFF: Link is stopped
X1	All axes	EC packet monitor active	Turns on when the monitoring of EtherCAT communication packet is executed by the EC packet monitor request (Y1). ON: Monitoring is executed, OFF: Monitoring stops
X2	All axes	Diagnosis mode	Indicates the unit is in the diagnosis mode. In the diagnosis mode, the motion control by FP7 MC Unit is not performed. In the diagnosis mode, the motion control by I/O cannot be executed and a warning occurred if it is requested.
X3	All axes	FROM writing active	Announces that data (positioning parameters, positioning tables) in the unit memory is being written in the FROM. ON: Writing is in progress, OFF: Writing is complete (Normal or abnormal end)
X4	All axes	Tool operation	Flag to indicate that the positioning unit is in tool operation. The start-up by a user program (output control area) is not available during the Tool operation. If it performs, a warning will occur. ON: Tool operation is being executed, OFF: Tool operation is not executed
X5	All axes	All groups setting done	Makes axis group setting changes in FP7 MC Unit with the axis group setting request (Y5) turned ON after making setting changes in the axis group with the program. The contact turns on upon completion of the setting changes.
X6	—	(Reserved for system)	-
X7	All axes	Recalculation done	The positioning data of the unit memory is restructured by turning on the recalculation request (Y7). This contact turns on after the completion of restructuring. If the recalculation request (Y7) turns on again, this contact will be off once. (Note) It is used only when the positioning data has been rewritten by ladder programs.
X8	All axes	Cam table reading done annunciation	The cam table is read by turning on the cam table reading request (Y8). This contact turns on after reading the cam table.
X9	All axes	Cam table rewriting done annunciation	The cam table is written by turning on the cam table rewriting request (Y9). This contact turns on after rewriting the cam table.
XA	All axes	EtherCAT communication stop annunciation	This contact turns on by turning on the EtherCAT communication stop request (YA).
XB	All axes	Waveform logging active annunciation	This contact turns On by turning on the waveform logging enable flag (YB).
XC	All axes	EMS switch request reception annunciation	ESM (EtherCAT State Machine) is switched by turning on the ESM switch request (YC). This contact turns on after switching the ESM. This contact turns off when the ESM switch request turns off from on.
XD	—	(Reserved for system)	-
XE	All axes	SD memory card access active	Turns on while accessing an SD memory card. ON: Access in progress, OFF: Access stops
XF	All axes	Initialization done	Indicates that the initial preparation of FP7 MC Unit has been completed by reading the setting data from the FROM in the unit when the power turns on. ON: FP7 MC Unit preparation done, OFF: FP7 MC Unit in preparation

(Note 1): The I/O numbers in the above table show relative addresses based on the base word number. The I/O numbers actually used vary according to the slot number where FP7 MC Unit is installed and the starting word number.

Example) The link establishment flag is X100 for slot number 1 if the starting word is number 10.

### ■ Allocation of I/O Numbers (Output)

I/O no.	Target axis	Name	Description
Y0	All axes	System stop	Request the system stop. When it turns on, all axes stops with the deceleration time of 1 ms. While this is on, all operation cannot be started.
Y1	All axes	EC packet monitor request	Requests the start of the monitor of EtherCAT communication packet when the EC packet monitor request flag is enabled by "MC common parameter". The packet data is saved in an SD memory card. The monitoring stops when (Y1) turns off. The monitoring also stops, and (X1) turns off when the packet monitor capacity reaches 6 Mbytes or 3904 packets.
Y2	—	—	—
Y3	All axes	FROM write request	Requests the writing of data (parameters, positioning tables) in the unit memory to the FROM. The FROM writing active flag (X3) is on during the writing, and (X3) turns off on completion of the writing. The writing result is stored in the unit memory (UM283).
Y4	—	(Reserved for system)	—
Y5	All axes	Axis group setting change request	This is used for changing the "Axis group setting" in the unit memory by user programs. Execute the following procedures by user programs. 1) Write data to "Axis group setting area". 2) Turn on "Axis group setting change request (Y5)". 3) After confirming "Axis group setting done flag (X5)" turns on, turn off (Y5).
Y6	—	(Reserved for system)	—
Y7	All axes	Recalculation request	This is used for changing the "positioning table data" stored in the system area within FP7 MC Unit by user programs. The positioning data after the table number starting the recalculation specified in the unit memory can be restructured and is executable by turning on this signal. Execute the following procedures by user programs. 1) Write data to "positioning table". 2) Turn on "Recalculation request (Y7)". 3) After confirming "Recalculation done flag (X7)" turns on, turn off (Y7). For details, refer to "8.9 Reconstruction of Positioning Data by User Programs".
Y8	All axes	Cam table reading request	Turn on this signal for reading cam tables. The cam table of a specified cam pattern number will be read when this signal turns on.
Y9	All axes	Cam table rewriting request	Turn on this signal for rewriting cam tables. The cam table of a specified cam pattern number will be rewritten when this signal turns on.
YA	All axes	EtherCAT communication stop request	Turn this signal on for stopping EtherCAT communication. Once the communication stops, XA turns on. Turning this signal off starts the communication.
YB	All axes	Waveform logging enable	When this signal is on, the waveform logging can be executed. When this signal is off, the waveform logging cannot be executed. When this flag turns off while the waveform logging is being executed, the waveform logging is aborted.
YC	All axes	ESM switch request	Turns on when changing ESM (EtherCAT State Machine) of all node/individual nodes is requested. When ESM is changed, XC turns on.
YD-YF	—	(Reserved for system)	—

(Note 1): The I/O numbers in the above table show relative addresses based on the base word number. The I/O numbers actually used vary according to the slot number where FP7 MC Unit is installed and the starting word number.

Example) The system stop request signal is Y100 for slot number 1 if the starting word is number 10.

## 16.3 Whole Configuration of Unit Memories

The unit memories of F7 MC Unit are configured as follows. For details of each area, refer to "16.4" to "16.11".

Name	Unit memory no. (Hex)	No. of occupied words	Description
Reserved area for the system	UM00000 - UM0007F	128 words	Reserved area for the system
Input control area	UM00080 - UM0017F	256 words	Input control area
Output control area	UM00180 - UM0027F	256 words	Output control area
Common area	UM00280 - UM0037F	256 words	Setting parameter control area
	UM00380 - UM003FF	128 words	Operation speed rate area
	UM00400 - UM0048F	144 words	Reserved area for the system
	UM00490 - UM0058F	256 words	Axis group setting area
	UM00590 - UM0068F	256 words	Current value update data area
	UM00690 - UM0071F	144 words	Reserved area for the system
	UM00720 - UM0076F	80 words	Torque control area
	UM00770 - UM0082F	192 words	Each axis information monitor & real speed monitor area
	UM00830 - UM0098F	352 words	Reserved for system
	UM00990 - UM009EF	96 words	Positioning control starting table number setting area
	UM009F0 - UM00A4F	96 words	Positioning control area
	UM00A50 - UM00A8F	64 words	Reserved area for the system
	UM00A90 - UM0170F	3,200 words	Error annunciation & clear area
	UM01710 - UM0238F	3,200 words	Warning annunciation & clear area
	UM02390 - UM025CF	576 words	Synchronous axis control monitor area For (6 words for each axis) x (64 real axes + 32 virtual axes)
UM025D0 - UM0260F	64 words	Reserved area for the system	
Reserved area for the system	UM02610 - UM0262F	32 words	Reserved area for the system
Time chart function control area	UM02630 - UM02637	8 words	Time chart function operation setting/annunciation area
ESM change control area	UM02638 - UM0263F	8 words	ESM change control area
Each axis information monitor area	UM02640 - UM0323F	3,072 words	Each axis information monitor area For (32 words for each axis) x (64 real axes + 32 virtual axes)

## 16.3 Whole Configuration of Unit Memories

Name	Unit memory no. (Hex)	No. of occupied words	Description
Each axis setting area	UM03240 - UM0623F	12,288 words	Parameter setting area For (128 words for each axis) x (64 real axes + 32 virtual axes)
	UM06240 - UM63EFF	384,192 words	No. of buffers: 24 For (16008 words for each buffer) x (24 buffers)
			The configuration per buffer is as follows. Buffer control area: 8 words Table data setting area: 16000 words
Reserved area for the system	UM63F00 - UM63F3F	64 words	Reserved area for the system
Synchronous control setting area	UM63F40 - UM6693F	10,752 words	For (112 words for each axis) x (64 real axes) The configuration per axis is as follows. Synchronous control setting area: 16 words Common setting area: 16 words clutch control area: 48 words Electronic cam setting area: 32 words
Positioning operation change setting area	UM66940 - UM66F3F	1,536 words	Positioning operation change setting area
Electronic cam pattern data editing area	UM66F40 - UM66F97	106 words	Electronic cam pattern editing area
Reserved area for the system	UM66FAA - UM7C4AF	64 words	Reserved area for the system
SDO communication area	UM7C4B0 - UM7C8BF	1,040 words	SDO communication header part: 16 words SDO communication data part: 1024 words
PDO communication area	UM7C8C0 - UM7DFEF	5,936 words	PDO communication area
Reserved area for the system	UM7DFF0 - UM7DFFB	12 words	Reserved area for the system
Diagnosis mode communication area	UM7DFFC -UM7DFFD	2 words	Diagnosis mode communication area
Reserved area for the system	UM7DFFE - UM7FFFF	8,194 words	Reserved area for the system

## Specifications

---

### ■ Reading from unit memories (UM)

It is possible to read the areas which are shown with "Available" in the "R" column in the following table using transfer instructions or arithmetic instructions with user programs. The operand of an instruction is specified by the combination of the slot number where the slot is installed and a unit memory number (UM).

Example) Program to read the input control area (UM00086-UM00089) of the FP7 MC Unit installed in the slot no. 1 (S1) to an arbitrary internal relay area (WR106-WR109)

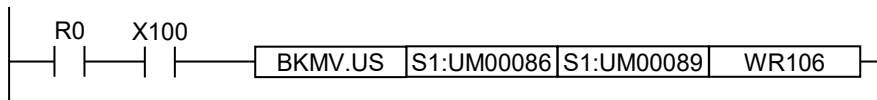

### ■ Writing to unit memories (UM)

- It is possible to write to the areas which are shown with "Available" in the "W" column in the following table using transfer instructions or arithmetic instructions with user programs. The operand of an instruction is specified by the combination of the slot number where the slot is installed and a unit memory number (UM).
- Be sure not to execute writing in the reserved areas for the system.

## 16.4 Unit Memories (Input and Output Control Areas)

### 16.4.1 Configuration of Input Control Area

Whole unit memory map		Starting no.	Name	No. of words
UM 0000	System area	UM 00080	Reserved area for the system	6 words
UM 0007F	128 words	UM 00086	Each axis connection confirmation	4 words
UM 00080	Input control area	UM 0008A	Servo lock	4 words
UM 0017F	256 words	UM 0008E	Reserved area for the system	2 words
UM 00180	Output control area	UM 00090	Busy	6 words
UM 0027F	256 words	UM 00096	Operation done	6 words
UM 00280	Common area	UM 0009C	Home return done	6 words
	9,104 words	UM 000A2	Near home input	4 words
UM 0260F	System area	UM 000A6	Reserved area for the system	6 words
UM 02610	48 words	UM 000AC	Auxiliary contact	6 words
UM 0263F	Each axis	UM 000B2	Limit + / Limit -	8 words
UM 02640	information area	UM 000BA	Error annunciation	6 words
	3,072 words	UM 000C0	Warning annunciation	6 words
UM 0323F	Each axis setting area	UM 000C6	Synchronous setting done	4 words
UM 03240	396,480 words	UM 000CA	Reserved area for the system	2 words
		UM 000CC	Synchronous cancel active annunciation	4 words
		UM 000D0	Reserved area for the system	2 words
		UM 000D2	Slave axis gear ratio change annunciation	4 words
		UM 000D6	Reserved area for the system	2 words
		UM 000D8	Slave axis clutch operation annunciation	4 words
		UM 000DC	Reserved area for the system	2 words
		UM 000DE	General-purpose input	32 words
		UM 000FE	Registered slave table	12 words
UM 63EFF	System area	UM 0010A	Network participating slave table	12 words
UM 63F00	64 words	UM 00116	Positioning speed change request reception annunciation	6 words
UM 63F3F	Synchronous control setting area	UM 0011C	Positioning movement amount change done annunciation	6 words
UM 63F40	10,752 words	UM 00122	Normal slave table	12 words
UM 6693F	Positioning operation change setting area	UM 0012E	Abnormal slave table	12 words
UM 66940	1,536 words	UM 0013A	Reserved area for the system	70 words
UM 66F3F	Cam pattern editing area			
UM 66F40	106 words			
UM 66FA9				

### 16.4.2 List of Input Control Area Functions

●: Available, -: Not available

Axis no.	Unit memory no. (Hex)	Name	Default	Description	R	W
-	UM 00080 -UM 00085	Reserved for system	-	-	-	-
1-16	UM 00086	Each axis connection confirmation	H0	When corresponding axes exist, the bits corresponding to each axis number turn on.	●	-
17-32	UM 00087					
33-48	UM 00088					
49-64	UM 00089					
1-16	UM 0008A	Servo lock	H0	When corresponding axes are in the servo-locked state, the bits corresponding to each axis number turn on. [The update cycle is communication (EtherCAT communication) cycle.] 0: Servo-free state 1: Servo-locked state	●	-
17-32	UM 0008B					
33-48	UM 0008C					
49-64	UM 0008D					
-	UM 0008E -UM 0008F	Reserved for system	-	-	-	-
1-16	UM 00090	Busy	H0	When axes are operating by the start request of each control (positioning, JOG operation, home return), the bits corresponding to each axis number turn on. They turn off on completion of the operation.	●	-
17-32	UM 00091					
33-48	UM 00092					
49-64	UM 00093					
Virtual 1-16	UM 00094					
Virtual 17-32	UM 00095					
1-16	UM 00096	Operation done	H0	When the running operation of each control (positioning, JOG operation, home return) is completed, the bits corresponding to each axis number turn on.  In the case of positioning control (P-, C-point control); they turn on when the execution of E-point table is completed. After this flag turns on the on-state will continue until the next control is activated.	●	-
17-32	UM 00097					
33-48	UM 00098					
49-64	UM 00099					
Virtual 1-16	UM 0009A					
Virtual 17-32	UM 0009B					

(Note 1): Flags for 16 axes are allocated to each area (1 word).

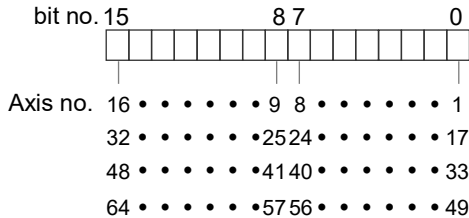



## 16.4 Unit Memories (Input and Output Control Areas)

●: Available, -: Not available

Axis no.	Unit memory no. (Hex)	Name	Default	Description	R	W
1-16	UM 0009C	Home return done	H0	When the home return operation is completed, the bits corresponding to each axis number turn on. After this flag turns on, the on state will continue until the next control is activated.	●	-
17-32	UM 0009D					
33-48	UM 0009E					
49-64	UM 0009F					
Virtual 1-16	UM 000A0					
Virtual 17-32	UM 000A1					
1-16	UM 000A2	Near home input	H0	Monitor flag for the near home input connected to the corresponding AMP. [The update cycle is communication (EtherCAT communication) cycle.]	●	-
17-32	UM 000A3					
33-48	UM 000A4					
49-64	UM 000A5					
-	UM 000A6 -UM 000AB	Reserved for system	-	-	-	-
1-16	UM 000AC	Auxiliary contact	H0	This contact is enabled when the auxiliary output function has been set.  When the positioning table is executed, the bits corresponding to each axis number turn on.  The ON time and delay ratio depends on the contents specified in the axis parameter.	●	-
17-32	UM 000AD					
33-48	UM 000AE					
49-64	UM 000AF					
Virtual 1-16	UM 000B0					
Virtual 17-32	UM 000B1					

(Note 1): Flags for 16 axes are allocated to each area (1 word).

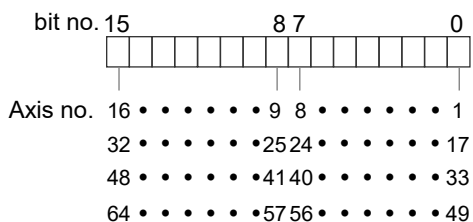

# Specifications

●: Available, -: Not available

Axis no.	Unit memory no. (Hex)	Name	Default	Description	R	W
1-8	UM 000B2	Limit + Limit -	H0	Monitor flag of the limit + input and limit - input connected to the corresponding AMP. [The update cycle is communication (EtherCAT communication) cycle.] When "Limit switch" in the axis parameter is set to "Enabled", the following inputs of AMP are monitored. -Limit switch +:SI-MON3 -Limit switch -: SI-MON4	●	-
9-16	UM 000B3					
17-24	UM 000B4					
25-32	UM 000B5					
33-40	UM 000B6					
41-48	UM 000B7					
49-56	UM 000B8					
57-64	UM 000B9					

(Note 1): Flags for 16 axes are allocated to each area (1 word).

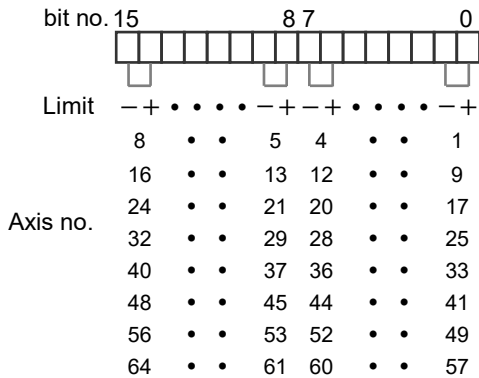



## Specifications

●: Available, -: Not available

Axis no.	Unit memory no. (Hex)	Name	Default	Description	R	W
1-16	UM 000D2	Slave axis gear ratio change annunciation	H0	Changes the gear ratio by the slave axis gear ratio change request of the output control area. After the completion of the change of gear ratio, the bits corresponding to each axis number turn on.	●	-
17-32	UM 000D3					
33-48	UM 000D4					
49-64	UM 000D5					
-	UM 000D6 -UM 000D7	Reserved for system	-	-	-	-
1-16	UM 000D8	Slave axis clutch operation annunciation	H0	Starts the clutch operation by turning on the slave axis clutch on request or clutch off request of the output control area. After the completion of the clutch operation, the bits corresponding to each axis number turn on.	●	-
17-32	UM 000D9					
33-48	UM 000DA					
49-64	UM 000DB					
-	UM 000DC -UM 000DD	Reserved for system	-	-	-	-

(Note 1): Flags for 16 axes are allocated to each area (1 word).

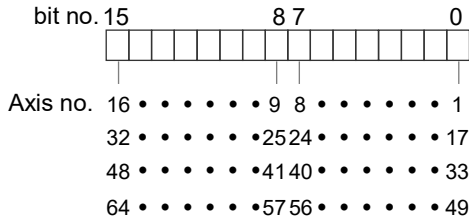

## 16.4 Unit Memories (Input and Output Control Areas)

●: Available, -: Not available

Axis no.	Unit memory no. (Hex)	Name	Default	Description	R	W																																					
1-2	UM 000DE	General-purpose input	H0	<p>Monitor flag for the general-purpose input connected to the corresponding AMP. The input status of this flag does not affect the operations of the motor and FP7 MC Unit.</p> <table border="1" style="width: 100%; border-collapse: collapse;"> <thead> <tr> <th style="width: 10%;">bit</th> <th style="width: 60%;">Signal name</th> <th style="width: 30%;">Axis no.</th> </tr> </thead> <tbody> <tr><td>0</td><td>NOT</td><td rowspan="8" style="vertical-align: middle;">1+2n</td></tr> <tr><td>1</td><td>POT</td></tr> <tr><td>2</td><td>HOME</td></tr> <tr><td>3</td><td>SI-MON1 / EXT1</td></tr> <tr><td>4</td><td>SI-MON2 / EXT2</td></tr> <tr><td>5</td><td>SI-MON3</td></tr> <tr><td>6</td><td>SI-MON4</td></tr> <tr><td>7</td><td>SI-MON5/ E-STOP</td></tr> <tr><td>8</td><td>NOT</td><td rowspan="8" style="vertical-align: middle;">2+2n</td></tr> <tr><td>9</td><td>POT</td></tr> <tr><td>10</td><td>HOME</td></tr> <tr><td>11</td><td>SI-MON1 / EXT1</td></tr> <tr><td>12</td><td>SI-MON2 / EXT2</td></tr> <tr><td>13</td><td>SI-MON3</td></tr> <tr><td>14</td><td>SI-MON4</td></tr> <tr><td>15</td><td>SI-MON5/ E-STOP</td></tr> </tbody> </table>	bit	Signal name	Axis no.	0	NOT	1+2n	1	POT	2	HOME	3	SI-MON1 / EXT1	4	SI-MON2 / EXT2	5	SI-MON3	6	SI-MON4	7	SI-MON5/ E-STOP	8	NOT	2+2n	9	POT	10	HOME	11	SI-MON1 / EXT1	12	SI-MON2 / EXT2	13	SI-MON3	14	SI-MON4	15	SI-MON5/ E-STOP	●	-
bit	Signal name				Axis no.																																						
0	NOT				1+2n																																						
1	POT																																										
2	HOME																																										
3	SI-MON1 / EXT1																																										
4	SI-MON2 / EXT2																																										
5	SI-MON3																																										
6	SI-MON4																																										
7	SI-MON5/ E-STOP																																										
8	NOT				2+2n																																						
9	POT																																										
10	HOME																																										
11	SI-MON1 / EXT1																																										
12	SI-MON2 / EXT2																																										
13	SI-MON3																																										
14	SI-MON4																																										
15	SI-MON5/ E-STOP																																										
3-4	UM 000DF																																										
5-6	UM 000E0																																										
7-8	UM 000E1																																										
9-10	UM 000E2																																										
11-12	UM 000E3																																										
13-14	UM 000E4																																										
15-16	UM 000E5																																										
17-18	UM 000E6																																										
19-20	UM 000E7																																										
21-22	UM 000E8																																										
23-24	UM 000E9																																										
25-26	UM 000EA																																										
27-28	UM 000EB																																										
29-30	UM 000EC																																										
31-32	UM 000ED																																										
33-34	UM 000EE																																										
35-36	UM 000EF																																										
37-38	UM 000F0																																										
39-40	UM 000F1																																										
41-42	UM 000F2																																										
43-44	UM 000F3																																										
45-46	UM 000F4																																										
47-48	UM 000F5																																										
49-50	UM 000F6																																										
51-52	UM 000F7																																										
53-54	UM 000F8																																										
55-56	UM 000F9																																										
57-58	UM 000FA																																										
59-60	UM 000FB																																										
61-62	UM 000FC																																										
63-64	UM 000FD																																										

# Specifications

●: Available, -: Not available

Slave no.	Unit memory no. (Hex)	Name	Default	Description	R	W
1-16	UM 000FE	Registered slave table	H0	Turns on bits corresponding to each station address (slave number) registered in ENI file.	●	-
17-32	UM 000FF					
33-48	UM 00100					
49-64	UM 00101					
65-80	UM 00102					
81-96	UM 00103					
97-112	UM 00104					
113-128	UM 00105					
129-144	UM 00106					
145-160	UM 00107					
161-176	UM 00108					
177-192	UM 00109					
1-16	UM 0010A	Network participating slave table	H0	Turns on the bits corresponding to each station address (slave number) in the OP mode out of the slaves participating in the network.	●	-
17-32	UM 0010B					
33-48	UM 0010C					
49-64	UM 0010D					
65-80	UM 0010E					
81-96	UM 0010F					
97-112	UM 00110					
113-128	UM 00111					
129-144	UM 00112					
145-160	UM 00113					
161-176	UM 00114					
177-192	UM 00115					

(Note 1): Sixteen node numbers are allocated to each area (1 word).

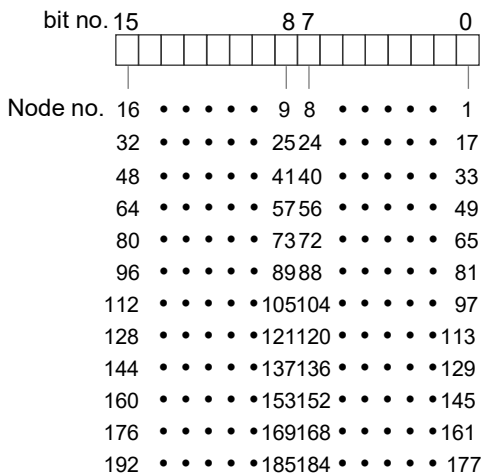



## Specifications

●: Available, -: Not available

Slave no.	Unit memory no. (Hex)	Name	Default	Description	R	W
1-16	UM 00122	Normal slave table	H0	Turns on bits corresponding to each station address (slave number) in the OP mode out of the slaves registered in ENI file and participating in the network.	●	-
17-32	UM 00123					
33-48	UM 00124					
49-64	UM 00125					
65-80	UM 00126					
81-96	UM 00127					
97-112	UM 00128					
113-128	UM 00129					
129-144	UM 0012A					
145-160	UM 0012B					
161-176	UM 0012C					
177-192	UM 0012D					
1-16	UM 0012E	Abnormal slave table	H0	Turns on bits corresponding to each station address (slave number) in any modes other than the OP mode out of the slaves registered in ENI file and participating in the network.	●	-
17-32	UM 0012F					
33-48	UM 00130					
49-64	UM 00131					
65-80	UM 00132					
81-96	UM 00133					
97-112	UM 00134					
113-128	UM 00135					
129-144	UM 00136					
145-160	UM 00137					
161-176	UM 00138					
177-192	UM 00139					

(Note 1): Sixteen node numbers are allocated to each area (1 word).

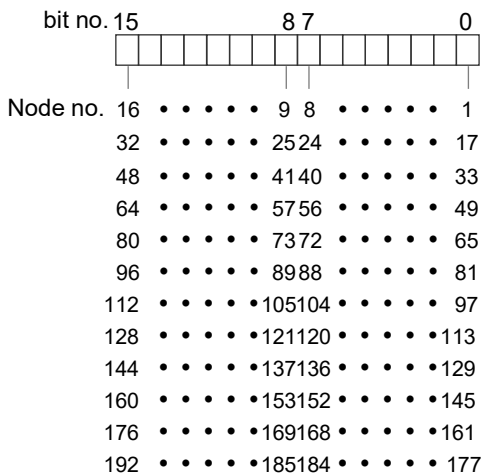



## 16.4 Unit Memories (Input and Output Control Areas)

●: Available, -: Not available

Slave no.	Unit memory no. (Hex)	Name	Default	Description	R	W
(Master)	UM 0013A	Current ESM state	H0	Indicates the current state of ESM (EtherCAT State Machine). Even in the diagnosis mode, the ESM state is stored.	●	-
1-4	UM 0013B					
5-6	UM 0013C					
9-12	UM 0013D					
13-16	UM 0013E					
17-20	UM 0013F					
21-24	UM 00140					
25-28	UM 00141					
29-32	UM 00142					
33-36	UM 00143					
37-40	UM 00144					
41-44	UM 00145					
45-48	UM 00146					
49-52	UM 00147					
53-56	UM 00148					
57-60	UM 00149					
61-64	UM 0014A					
65-68	UM 0014B					
69-72	UM 0014C					
73-76	UM 0014D					
77-80	UM 0014E					
81-84	UM 0014F					
85-88	UM 00150					
89-92	UM 00151					
93-96	UM 00152					
97-100	UM 00153					
101-104	UM 00154					
105-108	UM 00155					
109-112	UM 00156					
113-116	UM 00157					
117-120	UM 00158					
121-124	UM 00159					
125-128	UM 0015A					
129-132	UM 0015B					
133-136	UM 0015C					
137-140	UM 0015D					
141-144	UM 0015E					
145-148	UM 0015F					

bit	Name	Description
0	Node 1+4n	0001H: Init 0010H: Pre Operational 0100H: Safe Operational 1000H: OP
1		
2		
3		
4	Node 2+4n	
5		
6		
7		
8	Node 3+4n	
9		
10		
11		
12	Node 4+4n	
13		
14		
15		

➡ To the next page

## Specifications

●: Available, -: Not available

Slave no.	Unit memory no. (Hex)	Name	Default	Description	R	W
149-152	UM 00160	Current ESM state	H0	Refer to the previous page.	●	-
153-156	UM 00161					
157-160	UM 00162					
161-164	UM 00163					
165-168	UM 00164					
169-172	UM 00165					
173-176	UM 00166					
177-180	UM 00167					
181-184	UM 00168					
185-188	UM 00169					
189-192	UM 0016A					

## 16.4 Unit Memories (Input and Output Control Areas)

●: Available, -: Not available

Slave no.	Unit memory no. (Hex)	Name	Default	Description	R	W																																				
1-16	UM 0016B	Error Indicator annunciation	H0	Indicates the state of error indicator (ESC register #130_bit4) of each slave device. <table border="1" style="width: 100%; border-collapse: collapse;"> <thead> <tr> <th style="text-align: center;">bit</th> <th style="text-align: center;">Name</th> <th style="text-align: center;">Description</th> </tr> </thead> <tbody> <tr><td style="text-align: center;">0</td><td style="text-align: center;">Node 1+16n</td><td rowspan="16" style="text-align: center; vertical-align: middle;">0: OFF 1: ON</td></tr> <tr><td style="text-align: center;">1</td><td style="text-align: center;">Node 2+16n</td></tr> <tr><td style="text-align: center;">2</td><td style="text-align: center;">Node 3+16n</td></tr> <tr><td style="text-align: center;">3</td><td style="text-align: center;">Node 4+16n</td></tr> <tr><td style="text-align: center;">4</td><td style="text-align: center;">Node 5+16n</td></tr> <tr><td style="text-align: center;">5</td><td style="text-align: center;">Node 6+16n</td></tr> <tr><td style="text-align: center;">6</td><td style="text-align: center;">Node 7+16n</td></tr> <tr><td style="text-align: center;">7</td><td style="text-align: center;">Node 8+16n</td></tr> <tr><td style="text-align: center;">8</td><td style="text-align: center;">Node 9+16n</td></tr> <tr><td style="text-align: center;">9</td><td style="text-align: center;">Node 10+16n</td></tr> <tr><td style="text-align: center;">10</td><td style="text-align: center;">Node 11+16n</td></tr> <tr><td style="text-align: center;">11</td><td style="text-align: center;">Node 12+16n</td></tr> <tr><td style="text-align: center;">12</td><td style="text-align: center;">Node 13+16n</td></tr> <tr><td style="text-align: center;">13</td><td style="text-align: center;">Node 14+16n</td></tr> <tr><td style="text-align: center;">14</td><td style="text-align: center;">Node 15+16n</td></tr> <tr><td style="text-align: center;">15</td><td style="text-align: center;">Node 16+16n</td></tr> </tbody> </table>	bit	Name	Description	0	Node 1+16n	0: OFF 1: ON	1	Node 2+16n	2	Node 3+16n	3	Node 4+16n	4	Node 5+16n	5	Node 6+16n	6	Node 7+16n	7	Node 8+16n	8	Node 9+16n	9	Node 10+16n	10	Node 11+16n	11	Node 12+16n	12	Node 13+16n	13	Node 14+16n	14	Node 15+16n	15	Node 16+16n	●	-
bit	Name				Description																																					
0	Node 1+16n				0: OFF 1: ON																																					
1	Node 2+16n																																									
2	Node 3+16n																																									
3	Node 4+16n																																									
4	Node 5+16n																																									
5	Node 6+16n																																									
6	Node 7+16n																																									
7	Node 8+16n																																									
8	Node 9+16n																																									
9	Node 10+16n																																									
10	Node 11+16n																																									
11	Node 12+16n																																									
12	Node 13+16n																																									
13	Node 14+16n																																									
14	Node 15+16n																																									
15	Node 16+16n																																									
17-32	UM 0016C																																									
33-48	UM 0016D																																									
49-64	UM 0016E																																									
65-80	UM 0016F																																									
81-96	UM 00170																																									
97-112	UM 00171																																									
113-128	UM 00172																																									
129-144	UM 00173																																									
145-160	UM 00174																																									
161-176	UM 00175																																									
177-192	UM 00176																																									

(Note 1): Sixteen node numbers are allocated to each area (1 word).

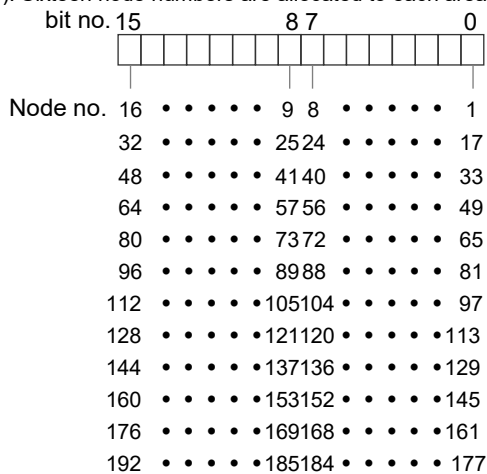

### 16.4.3 Configuration of Output Control Area

Whole unit memory map		Starting no.	Name	No. of words	
UM 00000	System area	UM 00180	Reserved area for the system	6 words	
UM 0007F UM 00080	128 words	UM 00186	Servo ON request	4 words	
UM 0017F UM 00180	Input control area 256 words	UM 0018A	Reserved area for the system	2 words	
UM 0027F UM 00280	Output control area 256 words	UM 0018C	Servo OFF request	4 words	
	Common area 9,104 words	UM 00190	Reserved area for the system	2 words	
		UM 00192	Positioning start request	6 words	
		UM 00198	Home return start request	6 words	
		UM 0019E	JOG operation Forward/Reverse request	12 words	
		UM 001AA	Inching operation request	6 words	
UM 0260F UM 02610		System area 48 words	UM 001B0	Emergency stop request	6 words
UM 0263F UM 02640		Each axis information area 3,072 words	UM 001B6	Deceleration stop request	6 words
		Each axis setting area 396,480 words	UM 001BC	J-point speed change request	6 words
			UM 001C2	J-point positioning start request	6 words
UM 0323F UM 03240				UM 001C8	Error clear request
	UM 001CE		Warning clear request	6 words	
	UM 001D4		Synchronous setting request	4 words	
	UM 001D8		Reserved area for the system	2 words	
	UM 001DA		Synchronous cancel request	4 words	
	UM 001DE		Reserved area for the system	2 words	
	UM 001E0		Slave axis gear ratio change request	4 words	
	UM 001E4		Reserved area for the system	2 words	
UM 63EFF UM 63F00	System area	UM 001E6	Slave axis clutch ON request	4 words	
UM 63F3F UM 63F40	Synchronous control setting area 10,752 words	UM 001EA	Reserved area for the system	2 words	
UM 6693F UM 66940	Positioning operation change setting area 1,536 words	UM 001EC	Slave axis clutch OFF request	4 words	
UM 66F3F UM 66F40	Cam pattern editing area	UM 001F0	Reserved area for the system	2 words	
UM 66FA9	106 words	UM 001F2	General-purpose output	8 words	
		UM 001FA	Reserved area for the system	134 words	
		UM 001FE	Positioning speed change request	6 words	
		UM 00204	Positioning movement amount change request	6 words	
		UM 0020A	Reserved area for the system	118 words	

### 16.4.4 List of Output Control Area Functions

●: Available, -: Not available

Axis no.	Unit memory no. (Hex)	Name	Default	Description	R	W
-	UM 00180 -UM 00185	Reserved for system	-	-	-	-
1-16	UM 00186	Servo ON request	H0	Requests the servo lock for the corresponding AMP.	●	●
17-32	UM 00187			This request signal is enabled when the bits corresponding to each axis number turn on. (The operation is the edge type.)		
33-48	UM 00188					
49-64	UM 00189					
-	UM 0018A -UM 0018B	Reserved for system	-	-	-	-
1-16	UM 0018C	Servo OFF request	H0	Requests the servo free for the corresponding AMP.	●	●
17-32	UM 0018D			This request signal is enabled when the bits corresponding to each axis number turn on. (The operation is the edge type.)		
33-48	UM 0018E					
49-64	UM 0018F					
-	UM 00190 -UM 00191	Reserved for system	-	-	-	-
1-16	UM 00192	Positioning start request	H0	Requests the positioning control start for the corresponding axis.	●	●
17-32	UM 00193			The starting table is specified in the area for specifying the position control starting table number in the unit memory.		
33-48	UM 00194			This request signal is enabled when the bits corresponding to each axis number turn on. (The operation is the edge type.)		
49-64	UM 00195					
Virtual 1-16	UM 00196					
Virtual 17-32	UM 00197					
1-16	UM 00198	Home return start request	H0	Requests the home return operation start for the corresponding axis.	●	●
17-32	UM 00199			This request signal is enabled when the bits corresponding to each axis number turn on. (The operation is the edge type.)		
33-48	UM 0019A					
49-64	UM 0019B					
Virtual 1-16	UM 0019C					
Virtual 17-32	UM 0019D					

(Note 1): Request flags for 16 axes are allocated to each area (1 word).

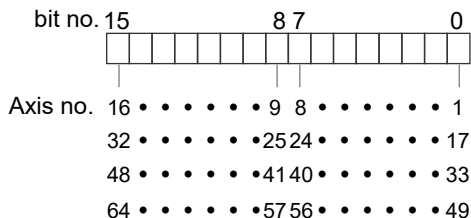

(Note 2): The servo cannot be free automatically even in the program mode. To make the servo free, turn on the Servo OFF request.

# Specifications

●: Available, -: Not available

Axis no.	Unit memory no. (Hex)	Name	Default	Description	R	W
1-8	UM 0019E	JOG operation forward/reverse request	H0	Requests the JOG forward or reverse operation for corresponding axes. In the case of JOG operation, this request signal is enabled when the bits corresponding to each axis number are on. (The operation is the level type.)  When the inching operation request is enabled, it functions as the request for the JOG inching forward or reverse operation. In the case of JOG inching operation, this request signal is enabled when the bits corresponding to each axis number turn on from off. (The operation is the edge type.)		
9-16	UM 0019F					
17-24	UM 001A0					
25-32	UM 001A1					
33-40	UM 001A2					
41-48	UM 001A3					
49-56	UM 001A4					
57-64	UM 001A5					
Virtual 1-8	UM 001A6					
Virtual 9-16	UM 001A7					
Virtual 17-24	UM 001A8					
Virtual 25-32	UM 001A9					
1-16	UM 001AA	Inching operation request	H0	Turns on the bits corresponding to each axis number for performing the JOG inching operation. The inching operation is enabled when the bits corresponding to each axis number are on. (The operation is the level type.)  When this request signal is on, the above "JOG operation forward/reverse request" functions as the start request for the JOG inching operation. When it is off, it functions as the normal request "JOG operation forward/reverse".		
17-32	UM 001AB					
33-48	UM 001AC					
49-64	UM 001AD					
Virtual 1-16	UM 001AE					
Virtual 17-32	UM 001AF					

(Note 1): Request flags for 8 axes are allocated to each area (1 word) of the JOG operation forward/reverse request.

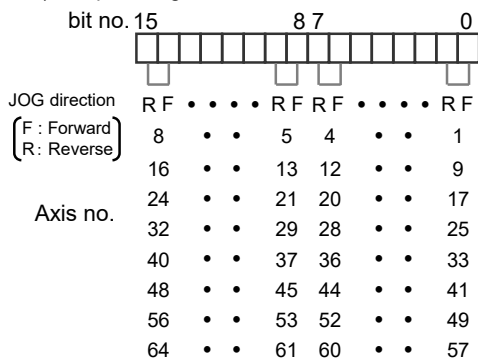

(Note 2): Request flags for 16 axes are allocated to each area (1 word) of the inching operation request.

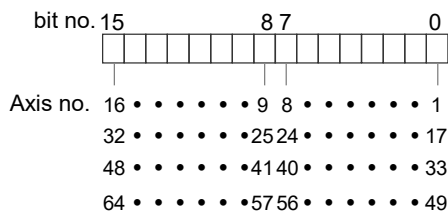



# Specifications

●: Available, -: Not available

Axis no.	Unit memory no. (Hex)	Name	Default	Description	R	W
1-16	UM 001CE	Warning clear request	H0	Requests the warning clear for FP7 MC Unit. Clears warnings and warning logs by turning on this request.	●	●
17-32	UM 001CF					
33-48	UM 001D0					
49-64	UM 001D1					
Virtual 1-16	UM 001D2					
Virtual 17-32	UM 001D3					
1-16	UM 001D4	Synchronous setting request	H0	This contact turns on after changing the parameter setting of synchronous operation.	●	●
17-32	UM 001D5					
33-48	UM 001D6					
49-64	UM 001D7					
-	UM 001D8 -UM 001D9	Reserved for system	-	-	-	-
1-16	UM 001DA	Synchronous cancel request	H0	Turns on the request for the amplifier to cancel the synchronous operation.  This request signal is enabled when the bits corresponding to each axis number are on. (The operation is the level type.)	●	●
17-32	UM 001DB					
33-48	UM 001DC					
49-64	UM 001DD					
-	UM 001DE -UM 001DF	Reserved for system	-	-	-	-
1-16	UM 001E0	Slave axis gear ratio change request	H0	Changes the gear ratio when the request flag for the corresponding axis during the synchronous operation turns on. (The operation is the edge type.)  This request signal is enabled when the bits corresponding to each axis number turn on. (The operation is the edge type.)	●	●
17-32	UM 001E1					
33-48	UM 001E2					
49-64	UM 001E3					
-	UM 001E4 -UM 001E5	Reserved for system	-	-	-	-
1-16	UM 001E6	Slave axis clutch ON request	H0	Starts the clutch on operation when the request flag for the corresponding axis during the synchronous operation turns on. * Amplifiers that no clutch is used do not operate. (Set the operation to level type, leading edge, or trailing edge.)	●	●
17-32	UM 001E7					
33-48	UM 001E8					
49-64	UM 001E9					
-	UM 001EA -UM 001EB	Reserved for system	-	-	-	-

(Note 1): Request flags for 16 axes are allocated to each area (1 word).

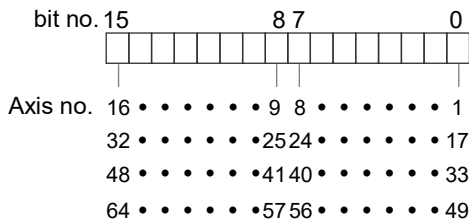



## 16.4 Unit Memories (Input and Output Control Areas)

●: Available, -: Not available

Axis no.	Unit memory no. (Hex)	Name	Default	Description	R	W
1-16	UM 001EC	Slave axis clutch OFF request	H0	Starts the clutch off operation when the request flag for the corresponding axis during the synchronous operation turns on. * Axes that no clutch is used do not operate. (Set the operation for leading edge, or trailing edge.) These signals will be disabled while the slave axis clutch on request signal is set to level type.	●	●
17-32	UM 001ED					
33-48	UM 001EE					
49-64	UM 001EF					
-	UM 001F0 -UM 001F1	Reserved for system	-	-	-	-

(Note 1): Request flags for 16 axes are allocated to each area (1 word).

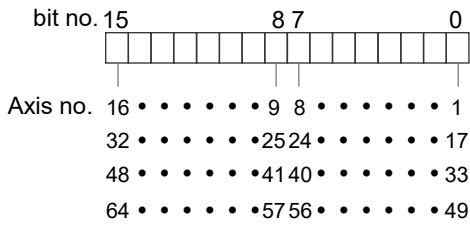

## Specifications

●: Available, -: Not available

Axis no.	Unit memory no. (Hex)	Name	Default	Description	R	W																																											
1-8	UM 001F2	General-purpose output	H0	General-purpose outputs connected to the corresponding AMP. <table border="1" style="margin-top: 10px;"> <thead> <tr> <th>bit</th> <th>Signal name</th> <th>Axis number</th> </tr> </thead> <tbody> <tr> <td>0</td> <td>set-brake</td> <td rowspan="2">1+8n</td> </tr> <tr> <td>1</td> <td>EX-OUT1</td> </tr> <tr> <td>2</td> <td>set-brake</td> <td rowspan="2">2+8n</td> </tr> <tr> <td>3</td> <td>EX-OUT1</td> </tr> <tr> <td>4</td> <td>set-brake</td> <td rowspan="2">3+8n</td> </tr> <tr> <td>5</td> <td>EX-OUT1</td> </tr> <tr> <td>6</td> <td>set-brake</td> <td rowspan="2">4+8n</td> </tr> <tr> <td>7</td> <td>EX-OUT1</td> </tr> <tr> <td>8</td> <td>set-brake</td> <td rowspan="2">5+8n</td> </tr> <tr> <td>9</td> <td>EX-OUT1</td> </tr> <tr> <td>10</td> <td>set-brake</td> <td rowspan="2">6+8n</td> </tr> <tr> <td>11</td> <td>EX-OUT1</td> </tr> <tr> <td>12</td> <td>set-brake</td> <td rowspan="2">7+8n</td> </tr> <tr> <td>13</td> <td>EX-OUT1</td> </tr> <tr> <td>14</td> <td>set-brake</td> <td rowspan="2">8+8n</td> </tr> <tr> <td>15</td> <td>EX-OUT1</td> </tr> </tbody> </table>	bit	Signal name	Axis number	0	set-brake	1+8n	1	EX-OUT1	2	set-brake	2+8n	3	EX-OUT1	4	set-brake	3+8n	5	EX-OUT1	6	set-brake	4+8n	7	EX-OUT1	8	set-brake	5+8n	9	EX-OUT1	10	set-brake	6+8n	11	EX-OUT1	12	set-brake	7+8n	13	EX-OUT1	14	set-brake	8+8n	15	EX-OUT1	●	●
bit	Signal name				Axis number																																												
0	set-brake				1+8n																																												
1	EX-OUT1																																																
2	set-brake				2+8n																																												
3	EX-OUT1																																																
4	set-brake				3+8n																																												
5	EX-OUT1																																																
6	set-brake				4+8n																																												
7	EX-OUT1																																																
8	set-brake	5+8n																																															
9	EX-OUT1																																																
10	set-brake	6+8n																																															
11	EX-OUT1																																																
12	set-brake	7+8n																																															
13	EX-OUT1																																																
14	set-brake	8+8n																																															
15	EX-OUT1																																																
9-16	UM 001F3																																																
17-24	UM 001F4																																																
25-32	UM 001F5																																																
33-40	UM 001F6																																																
41-48	UM 001F7																																																
49-56	UM 001F8																																																
57-64	UM 001F9																																																
-	UM 001FA -UM 001FD	Reserved for system	-	-	-	-																																											

(Note): For details of the method of using "set-brake", refer to the technical data of A6B/A5B.

## 16.4 Unit Memories (Input and Output Control Areas)

●: Available, -: Not available

Axis no.	Unit memory no. (Hex)	Name	Default	Description	R	W
1-16	UM 001FE	Positioning speed change request	H0	Starts the speed change operation when the positioning speed change request turns on.	●	●
17-32	UM 001FF					
33-48	UM 00200					
49-64	UM 00201					
Virtual 1-16	UM 00202					
Virtual 17-32	UM 00203					
1-16	UM 00204	Positioning movement amount change request	H0	Starts the movement amount change operation when the positioning movement amount change request turns on	●	●
17-32	UM 00205					
33-48	UM 00206					
49-64	UM 00207					
Virtual 1-16	UM 00208					
Virtual 17-32	UM 00209					

(Note 1): Request flags for 16 axes are allocated to each area (1 word).

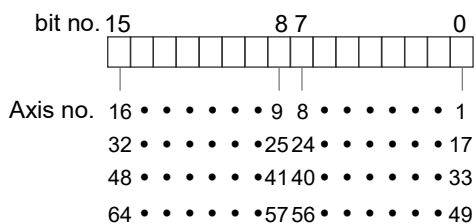

# Specifications

●: Available, -: Not available

Slave no.	Unit memory no. (Hex)	Name	Default	Description	R	W																																				
1-16	UM 0020A	Error Indicator clear request	H0	Requests to clear the error indicator (ESC register #130_bit4) of each slave device. <table border="1" style="width: 100%; border-collapse: collapse;"> <thead> <tr> <th>bit</th> <th>Name</th> <th>Description</th> </tr> </thead> <tbody> <tr><td>0</td><td>Node 1+16n</td><td rowspan="16">0: Not request clearance 1: Request clearance</td></tr> <tr><td>1</td><td>Node 2+16n</td></tr> <tr><td>2</td><td>Node 3+16n</td></tr> <tr><td>3</td><td>Node 4+16n</td></tr> <tr><td>4</td><td>Node 5+16n</td></tr> <tr><td>5</td><td>Node 6+16n</td></tr> <tr><td>6</td><td>Node 7+16n</td></tr> <tr><td>7</td><td>Node 8+16n</td></tr> <tr><td>8</td><td>Node 9+16n</td></tr> <tr><td>9</td><td>Node 10+16n</td></tr> <tr><td>10</td><td>Node 11+16n</td></tr> <tr><td>11</td><td>Node 12+16n</td></tr> <tr><td>12</td><td>Node 13+16n</td></tr> <tr><td>13</td><td>Node 14+16n</td></tr> <tr><td>14</td><td>Node 15+16n</td></tr> <tr><td>15</td><td>Node 16+16n</td></tr> </tbody> </table>	bit	Name	Description	0	Node 1+16n	0: Not request clearance 1: Request clearance	1	Node 2+16n	2	Node 3+16n	3	Node 4+16n	4	Node 5+16n	5	Node 6+16n	6	Node 7+16n	7	Node 8+16n	8	Node 9+16n	9	Node 10+16n	10	Node 11+16n	11	Node 12+16n	12	Node 13+16n	13	Node 14+16n	14	Node 15+16n	15	Node 16+16n	●	●
bit	Name				Description																																					
0	Node 1+16n				0: Not request clearance 1: Request clearance																																					
1	Node 2+16n																																									
2	Node 3+16n																																									
3	Node 4+16n																																									
4	Node 5+16n																																									
5	Node 6+16n																																									
6	Node 7+16n																																									
7	Node 8+16n																																									
8	Node 9+16n																																									
9	Node 10+16n																																									
10	Node 11+16n																																									
11	Node 12+16n																																									
12	Node 13+16n																																									
13	Node 14+16n																																									
14	Node 15+16n																																									
15	Node 16+16n																																									
17-32	UM 0020B																																									
33-48	UM 0020C																																									
49-64	UM 0020D																																									
65-80	UM 0020E																																									
81-96	UM 0020F																																									
97-112	UM 00210																																									
113-128	UM 00211																																									
129-144	UM 00212																																									
145-160	UM 00213																																									
161-176	UM 00214																																									
177-192	UM 00215																																									
-	UM 00216 -UM 0027F	Reserved for system	-	-	-	-																																				

(Note 1): Request flags for 16 axes are allocated to each area (1 word).

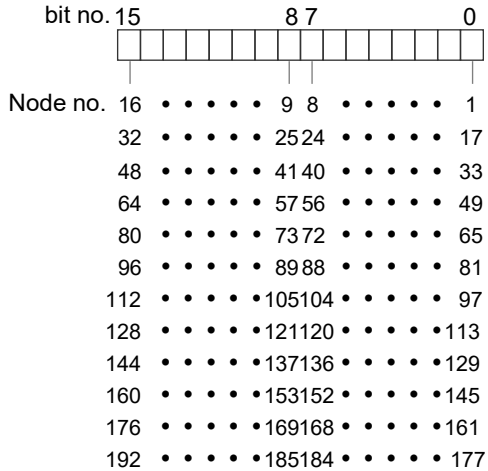

## 16.5 Unit Memories (Common Area)

### 16.5.1 Configuration of Common Area

Whole unit memory map		Starting no.	Name	No. of words
UM 00000	System area	UM 00280	Setting parameter control area	256 words
UM 0007F	128 words	UM 00380	Operation speed rate area	128 words
UM 00080	Input control area	UM 00400	Reserved area for the system	144 words
UM 0017F	256 words	UM 00490	Axis group setting area	256 words
UM 00180	Output control area	UM 00590	Current value update data area	256 words
UM 0027F	256 words	UM 00690	Reserved area for the system	144 words
UM 00280	Common area	UM 00720	Torque control area	80 words
	9,104 words	UM 00770	Each axis information monitor & actual speed monitor area	192 words
UM 0260F	System area	UM 00830	Reserved area for the system	352 words
UM 02610	48 words	UM 00990	Positioning control starting table no. setting area	96 words
UM 0263F	Each axis information area	UM 009F0	Positioning control area	96 words
UM 02640	3,072 words	UM 00A50	Reserved area for the system	64 words
UM 0323F	Each axis setting area	UM 00A90	Error annunciation & clear area	3,200 words
UM 03240	396,480 words	UM 01710	Warning annunciation & clear area	3,200 words
UM 63EFF	System area	UM 02390	Synchronous control monitor area	576 words
UM 63F00	64 words	UM 025D0	Reserved area for the system	64 words
UM 63F3F	Synchronous control setting area			
UM 63F40	10,752 words			
UM 6693F	Positioning operation change setting area			
UM 66940	1,536 words			
UM 66F3F	Cam pattern editing area			
UM 66F40	106 words			
UM 66FA9				

### 16.5.2 Setting Parameter Control Area

●: Available, -: Not available

Axis no.	Unit memory no. (Hex)	Name	Default	Description	R	W
-	UM 00280 -UM 00281	Number of writing to FROM	U0	Announces the number of writing the positioning parameters and data in the unit memory into FROM.	●	-
-	UM 00282	Reserved for system	-	-	-	-
-	UM 00283	FROM write result	H0	FROM writing in progress: H5555 FROM writing ended normally: H0 FROM writing ended abnormally: HFFFF FROM writing by CMI in progress: HAAAA	●	-
1	UM 00284	Recalculation starting table number	U1	This is used to rewrite positioning data using a user program. Reconstructs the positioning data which starts with the table number specified in this area when the recalculation request (Y7) turns on. Range: 1 to 1000	●	●
1	UM 00285	Recalculation starting table size	U1	Reconstructs the positioning data of the table size specified in this area when the recalculation request (Y7) turns on. Range: 1 to 500	●	●
(2-64 Virtual 1-32)	UM 00286 -UM 00343	The following areas are allocated to each axis. ● Recalculation starting table number: 1 word ● Recalculation starting table size: 1 word			●	●
-	UM 00344 -UM 0037F	Reserved for system	-	-	-	-

### 16.5.3 Operation Speed Rate Area

●: Available, -: Not available

Axis no.	Unit memory no. (Hex)	Name	Default	Description	R	W
1	UM 00380	Operation speed rate	U100	All operations relating to axes (positioning, JOG operation, home return) can be performed at the specified rate. Range:0-500 [%] (For single axis control) Range:0-200 [%] (For interpolation control)	●	●
(2-64 Virtual 1-32)	UM 00381 -UM 003DF	The following areas are allocated to each axis. ● Operation speed rate: 1 word			●	●
-	UM 003E0 -UM 003FF	Reserved for system	-	-	-	-

16.5.4 Axis Group Setting Area

●: Available, -: Not available

Axis no.	Unit memory no. (Hex)	Name	Default	Description	R	W
1-16	UM 00490	Interpolation group 1 setting	H0	Set either independent or interpolation for each axis in this area. In case of interpolation, each axis belongs to any group 1 to 32. For example, the axes 1, 2 and 3 belong to group 1 and are 3-axis interpolation, set the corresponding 3 bits to on (1) in the interpolation axis setting of group 1.  In the case of single axis independent setting, set the corresponding bits to off (0).  Maximum number of interpolation axis per group is 3. The same axis cannot be set in more than one group.	●	●
17-32	UM 00491					
33-48	UM 00492					
49-64	UM 00493					
Virtual 1-16	UM 00494					
Virtual 17-32	UM 00495					
-	UM 00496 -UM 00549	For interpolation groups 2 to 31, 6 words are allocated to each group.		●	●	
1-16	UM 0054A	Interpolation group 32 setting	H0	Same as above.	●	●
17-32	UM 0054B					
33-48	UM 0054C					
49-64	UM 0054D					
Virtual 1-16	UM 0054E					
Virtual 17-32	UM 0054F					
1-16	UM 00550	Independent axis setting	H0	The bit corresponding to the axis is; 0: Belongs to interpolation group or the axis is not set as a used axis.  1: Independent (Not belong to interpolation group)  An error occurs when this overlaps with the setting of interpolation group.	●	●
17-32	UM 00551					
33-48	UM 00552					
49-64	UM 00553					
Virtual 1-16	UM 00554					
Virtual 17-32	UM 00555					
-	UM 00556 -UM 0058F	Reserved for system	-	-	-	-

(Note 1): Bits for 16 axes are allocated to each area (1 word).

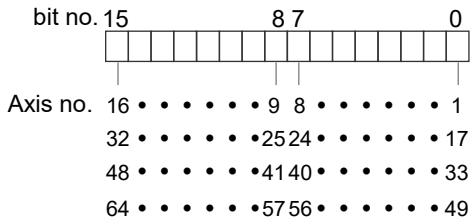

16.5.5 Current Value Update Data Area

●: Available, -: Not available

Axis no.	Unit memory no. (Hex)	Name	Default	Description	R	W																																				
1-16	UM 00590	Current value update request	H0	Changes "Unit system conversion current value" managed by FP7 MC Unit to "current value update coordinate" only when the bit corresponding to each axis number changes to 1 from 0. After the change, FP7 MC Unit clears the corresponding bits to 0 automatically.	●	●																																				
17-32	UM 00591			<table border="1"> <thead> <tr> <th>bit</th> <th>Name</th> <th>Description</th> </tr> </thead> <tbody> <tr> <td>0</td> <td>Axis 1+16n Current value update request</td> <td rowspan="16">0: No change 1: Update the current value after unit conversion of a target axis</td> </tr> <tr> <td>1</td> <td>Axis 2+16n Current value update request</td> </tr> <tr> <td>2</td> <td>Axis 3+16n Current value update request</td> </tr> <tr> <td>3</td> <td>Axis 4+16n Current value update request</td> </tr> <tr> <td>4</td> <td>Axis 5+16n Current value update request</td> </tr> <tr> <td>5</td> <td>Axis 6+16n Current value update request</td> </tr> <tr> <td>6</td> <td>Axis 7+16n Current value update request</td> </tr> <tr> <td>7</td> <td>Axis 8+16n Current value update request</td> </tr> <tr> <td>8</td> <td>Axis 9+16n Current value update request</td> </tr> <tr> <td>9</td> <td>Axis 10+16n Current value update request</td> </tr> <tr> <td>10</td> <td>Axis 11+16n Current value update request</td> </tr> <tr> <td>11</td> <td>Axis 12+16n Current value update request</td> </tr> <tr> <td>12</td> <td>Axis 13+16n Current value update request</td> </tr> <tr> <td>13</td> <td>Axis 14+16n Current value update request</td> </tr> <tr> <td>14</td> <td>Axis 15+16n Current value update request</td> </tr> <tr> <td>15</td> <td>Axis 16+16n Current value update request</td> </tr> </tbody> </table>			bit	Name	Description	0	Axis 1+16n Current value update request	0: No change 1: Update the current value after unit conversion of a target axis	1	Axis 2+16n Current value update request	2	Axis 3+16n Current value update request	3	Axis 4+16n Current value update request	4	Axis 5+16n Current value update request	5	Axis 6+16n Current value update request	6	Axis 7+16n Current value update request	7	Axis 8+16n Current value update request	8	Axis 9+16n Current value update request	9	Axis 10+16n Current value update request	10	Axis 11+16n Current value update request	11	Axis 12+16n Current value update request	12	Axis 13+16n Current value update request	13	Axis 14+16n Current value update request	14	Axis 15+16n Current value update request	15	Axis 16+16n Current value update request
bit	Name			Description																																						
0	Axis 1+16n Current value update request			0: No change 1: Update the current value after unit conversion of a target axis																																						
1	Axis 2+16n Current value update request																																									
2	Axis 3+16n Current value update request																																									
3	Axis 4+16n Current value update request																																									
4	Axis 5+16n Current value update request																																									
5	Axis 6+16n Current value update request																																									
6	Axis 7+16n Current value update request																																									
7	Axis 8+16n Current value update request																																									
8	Axis 9+16n Current value update request																																									
9	Axis 10+16n Current value update request																																									
10	Axis 11+16n Current value update request																																									
11	Axis 12+16n Current value update request																																									
12	Axis 13+16n Current value update request																																									
13	Axis 14+16n Current value update request																																									
14	Axis 15+16n Current value update request																																									
15	Axis 16+16n Current value update request																																									
33-48	UM 00592																																									
49-64	UM 00593																																									
Virtual 1-16	UM 00594																																									
Virtual 17-32	UM 00595																																									





### 16.5.6 Torque Limit Area

The output torque from Servo amplifier to a motor can be changed. The setting range is 1 to 5000. It is equivalent to 0.1 to 500.0%. It cannot be changed during positioning operation. The changed made during positioning operation will be reflected at the next startup time.

●: Available, -: Not available

Axis no.	Unit memory no. (Hex)	Name	Default	Description	R	W																																				
1-16	UM 00720	Torque limit enable flag	H0	Set the corresponding bits of axes for the torque limit to "1". <table border="1" style="width: 100%; border-collapse: collapse;"> <thead> <tr> <th>bit.</th> <th>Name</th> <th>Description</th> </tr> </thead> <tbody> <tr> <td>0</td> <td>Axes 1+16n Torque limit enabled</td> <td rowspan="15">0: Torque limit disabled 1: Torque limit enabled</td> </tr> <tr> <td>1</td> <td>Axes 2+16n Torque limit enabled</td> </tr> <tr> <td>2</td> <td>Axes 3+16n Torque limit enabled</td> </tr> <tr> <td>3</td> <td>Axes 4+16n Torque limit enabled</td> </tr> <tr> <td>4</td> <td>Axes 5+16n Torque limit enabled</td> </tr> <tr> <td>5</td> <td>Axes 6+16n Torque limit enabled</td> </tr> <tr> <td>6</td> <td>Axes 7+16n Torque limit enabled</td> </tr> <tr> <td>7</td> <td>Axes 8+16n Torque limit enabled</td> </tr> <tr> <td>8</td> <td>Axes 9+16n Torque limit enabled</td> </tr> <tr> <td>9</td> <td>Axes 10+16n Torque limit enabled</td> </tr> <tr> <td>10</td> <td>Axes 11+16n Torque limit enabled</td> </tr> <tr> <td>11</td> <td>Axes 12+16n Torque limit enabled</td> </tr> <tr> <td>12</td> <td>Axes 13+16n Torque limit enabled</td> </tr> <tr> <td>13</td> <td>Axes 14+16n Torque limit enabled</td> </tr> <tr> <td>14</td> <td>Axes 15+16n Torque limit enabled</td> </tr> <tr> <td>15</td> <td>Axes 16+16n Torque limit enabled</td> </tr> </tbody> </table>	bit.	Name	Description	0	Axes 1+16n Torque limit enabled	0: Torque limit disabled 1: Torque limit enabled	1	Axes 2+16n Torque limit enabled	2	Axes 3+16n Torque limit enabled	3	Axes 4+16n Torque limit enabled	4	Axes 5+16n Torque limit enabled	5	Axes 6+16n Torque limit enabled	6	Axes 7+16n Torque limit enabled	7	Axes 8+16n Torque limit enabled	8	Axes 9+16n Torque limit enabled	9	Axes 10+16n Torque limit enabled	10	Axes 11+16n Torque limit enabled	11	Axes 12+16n Torque limit enabled	12	Axes 13+16n Torque limit enabled	13	Axes 14+16n Torque limit enabled	14	Axes 15+16n Torque limit enabled	15	Axes 16+16n Torque limit enabled	●	●
bit.	Name				Description																																					
0	Axes 1+16n Torque limit enabled				0: Torque limit disabled 1: Torque limit enabled																																					
1	Axes 2+16n Torque limit enabled																																									
2	Axes 3+16n Torque limit enabled																																									
3	Axes 4+16n Torque limit enabled																																									
4	Axes 5+16n Torque limit enabled																																									
5	Axes 6+16n Torque limit enabled																																									
6	Axes 7+16n Torque limit enabled																																									
7	Axes 8+16n Torque limit enabled																																									
8	Axes 9+16n Torque limit enabled																																									
9	Axes 10+16n Torque limit enabled																																									
10	Axes 11+16n Torque limit enabled																																									
11	Axes 12+16n Torque limit enabled																																									
12	Axes 13+16n Torque limit enabled																																									
13	Axes 14+16n Torque limit enabled																																									
14	Axes 15+16n Torque limit enabled																																									
15	Axes 16+16n Torque limit enabled																																									
17-32	UM 00721																																									
33-48	UM 00722																																									
49-64	UM 00723																																									
1	UM 00724	Torque limit value	U3000	Set the torque limit values. Range: U1 to U5000 (0.1% to 500.0%) Example) If "U2000" is written, it operates with "2000 x 0.1 = 200 (%)" as the maximum torque.	●	●																																				
(2-64 Virtual 1-32)	UM 00725 -UM 00763	The following areas are allocated to each axis. ● Torque limit value: 1 word			●	●																																				

### 16.5.7 Actual Speed Monitor Area

●: Available, -: Not available

Axis no.	Unit memory no. (Hex)	Name	Default	Description	R	W
1	UM 00770 -UM 00771	Actual speed monitor value [2 words]	U0	The actual speed monitor value is stored. ● For command unit/s, the ranges vary depending on the unit settings as below pulse: 0 to 2,147,483,647 pps μm: 0 to 2,147,483,647 μm/s inch: 0 to 2,147,483.647 inch/s degree: 0 to 2,147,483.647 rev/s ● For 0.1 rpm: 0 to 6500.0	●	-
(2-64)	UM 00722 -UM 007EF	The following areas are allocated to each axis. ● Actual speed monitor value: 2 words			●	-

(Note): When "Extend monitor value" in MC common settings is set to "1word", this area is always "0".

### 16.5.8 Positioning Control Starting Table Number Setting Area

●: Available, -: Not available

Axis no.	Unit memory no. (Hex)	Name	Default	Description	R	W
1	UM 00990	Positioning control start table number	U1	Set the table number of each axis starting the position control. Range: Standard area: 1 to 1000 Expansion area: 10,001 to 10,100	●	●
(2-64 Virtual 1-32)	UM 00991 -UM 009EF	The following areas are allocated to each axis. ● Positioning control start table number: 1 word			●	●

**16.5.9 Positioning Control Area**

●: Available, -: Not available

Axis no.	Unit memory no. (Hex)	Name	Default	Description	R	W
1	UM 009F0	Positioning repeat count	U0	Set the number of times for repeating the operation from the positioning control starting table number until the E-point control. Range: 0 to 255 When setting 0 or 1, the operation is executed only once. When setting 255, the operation is repeated unlimitedly until the operation is stopped.	●	●
(2-64 Virtual 1-32)	UM 009F1 -UM 00A4F	The following areas are allocated to each axis. ● Positioning repeat count: 1 word			●	●
-	UM 00A50 -UM 00A8F	Reserved for system	-	-	-	-

16.5.10 Error Annunciation and Clear Area

●: Available, -: Not available

Axis no.	Unit memory no. (Hex)	Name	Default	Description	R	W
-	UM 00A90 -UM 00A95	Reserved for system	-	-	-	-
1-16	UM 00A96	Error clear individual axis setting	H0	Clears the error of the axis for the corresponding bit. After changing the corresponding bit to 1, FP7 MC Unit clears the corresponding bit to 0 automatically.	●	●
17-32	UM 00A97					
33-48	UM 00A98					
49-64	UM 00A99					
Virtual 1-16	UM 00A9A					
Virtual 17-32	UM 00A9B					
-	UM 00A9C -UM00ABF	Reserved for system	-	-	-	-

(Note 1): Bits for 16 axes are allocated to the error clear individual axis setting area (1 word).

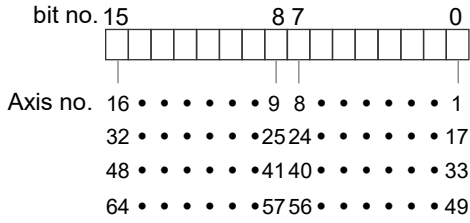

## Specifications

●: Available, -: Not available

Axis no.	Unit memory no. (Hex)	Name	Default	Description	R	W
1	UM 00AC0	No. of occurrences of errors	U0	Annunciates the number of occurrences of errors on the 1st axis.	●	-
1	UM 00AC1	Reserved for system	-	-	-	-
1	UM 00AC2 -UM 00AC3	Error code Buffer 1	H0	Stores the latest error code (8-digit hex) from the buffer 1 in order.	●	-
1	UM 00AC4 -UM 00AC5	Error code Buffer 2	H0			
1	UM 00AC6 -UM 00AC7	Error code Buffer 3	H0			
1	UM 00AC8 -UM 00AC9	Error code Buffer 4	H0			
1	UM 00ACA -UM 00ACB	Error code Buffer 5	H0			
1	UM 00ACC -UM 00ACD	Error code Buffer 6	H0			
1	UM 00ACE -UM 00ACF	Error code Buffer 7	H0			
1	UM 00AD0 -UM 00AD1	Error code Buffer 8	H0			
1	UM 00AD2 -UM 00ADF	Reserved for system	-	-	-	-
(2-64 Virtual 1-32)	UM 00AE0 -UM 016BF	As well as the area for axis 1, 32-word area is allocated to each axis in the following configuration. <ul style="list-style-type: none"> <li>● Number of occurrences of errors: 1 word</li> <li>● Reserved area for the system: 1 word</li> <li>● Error code buffer: 2 words x 8</li> <li>● Reserved area for the system: 14 words</li> </ul>			●	-
-	UM 016C0 -UM 0170F	Reserved for system	-	-	-	-

(Note 1): As for the unit memories in which error codes are stored, 2-word area is allocated for each axis.

(Note 2): The difference between the unit memory number of the target axis number and the unit memory number of the adjacent axis number is H20 (for 32 words).



## Specifications

●: Available, -: Not available

Axis no.	Unit memory no. (Hex)	Name	Default	Description	R	W
1	UM 01740	No. of occurrences of warnings	U0	Annunciates the number of occurrences of warnings on the 1st axis.	●	-
1	UM 01741	Reserved for system	-	-	-	-
1	UM 01742 -UM 01743	Warning code Buffer 1	H0	Stores the latest warning code (8-digit hex) from the buffer 1 in order.	●	-
1	UM 01744 -UM 01745	Warning code Buffer 2	H0			
1	UM 01746 -UM 01747	Warning code Buffer 3	H0			
1	UM 01748 -UM 01749	Warning code Buffer 4	H0			
1	UM 0174A -UM 0174B	Warning code Buffer 5	H0			
1	UM 0174C -UM 0174D	Warning code Buffer 6	H0			
1	UM 0174E -UM 0174F	Warning code Buffer 7	H0			
1	UM 01750 -UM 01751	Warning code Buffer 8	H0			
1	UM 01752 -UM 0175F	Reserved for system	-			
(2-64 Virtual 1-32)	UM 01760 -UM 0233F	As well as the area for axis 1, 32-word area is allocated to each axis in the following configuration. ● Number of occurrences of warnings: 1 word ● Reserved area for the system: 1 word ● Warning code buffer: 2 words x 8 ● Reserved area for the system: 14 words			●	-
-	UM 02340 -UM 0238F	Reserved for system	-	-	-	-

(Note 1): As for the unit memories in which warning codes are stored, 2-word area is allocated for each axis.

(Note 2): The difference between the unit memory number of the target axis number and the unit memory number of the adjacent axis number is H20 (for 32 words).



16.5.12 Synchronous Control Monitor Area

●: Available, -: Not available

Axis no.	Unit memory no. (Hex)	Name	Default	Description	R	W																																												
1	UM 02390	Synchronous master axis information monitor	HFFFF	<p>Stores the information on the master axis of synchronous control.</p> <table border="1"> <thead> <tr> <th colspan="2">Value</th> <th rowspan="2">Master axis</th> </tr> <tr> <th>Under synchronous control</th> <th>Synchronous control canceled</th> </tr> </thead> <tbody> <tr> <td>H FFFF</td> <td>H FFFF</td> <td>No synchronous setting</td> </tr> <tr> <td>H 0000</td> <td>H 8000</td> <td>The target axis for monitoring is the master axis. (For FP7 MC Unit, the value for the master axis does not change even when the synchronous control is canceled.)</td> </tr> <tr> <td>H 0001</td> <td>H 8001</td> <td>Axis 1</td> </tr> <tr> <td>H 0002</td> <td>H 8002</td> <td>Axis 2</td> </tr> <tr> <td>:</td> <td>:</td> <td>:</td> </tr> <tr> <td>H 0010</td> <td>H 8010</td> <td>Axis 16</td> </tr> <tr> <td>:</td> <td>:</td> <td>:</td> </tr> <tr> <td>H 0020</td> <td>H 8020</td> <td>Axis 32</td> </tr> <tr> <td>:</td> <td>:</td> <td>:</td> </tr> <tr> <td>H 0040</td> <td>H 8040</td> <td>Axis 64</td> </tr> <tr> <td>H 0041</td> <td>H 8041</td> <td>Virtual axis 1</td> </tr> <tr> <td>:</td> <td>:</td> <td>:</td> </tr> <tr> <td>H 0060</td> <td>H 8060</td> <td>Virtual axis 32</td> </tr> </tbody> </table>	Value		Master axis	Under synchronous control	Synchronous control canceled	H FFFF	H FFFF	No synchronous setting	H 0000	H 8000	The target axis for monitoring is the master axis. (For FP7 MC Unit, the value for the master axis does not change even when the synchronous control is canceled.)	H 0001	H 8001	Axis 1	H 0002	H 8002	Axis 2	:	:	:	H 0010	H 8010	Axis 16	:	:	:	H 0020	H 8020	Axis 32	:	:	:	H 0040	H 8040	Axis 64	H 0041	H 8041	Virtual axis 1	:	:	:	H 0060	H 8060	Virtual axis 32	●	-
Value		Master axis																																																
Under synchronous control	Synchronous control canceled																																																	
H FFFF	H FFFF	No synchronous setting																																																
H 0000	H 8000	The target axis for monitoring is the master axis. (For FP7 MC Unit, the value for the master axis does not change even when the synchronous control is canceled.)																																																
H 0001	H 8001	Axis 1																																																
H 0002	H 8002	Axis 2																																																
:	:	:																																																
H 0010	H 8010	Axis 16																																																
:	:	:																																																
H 0020	H 8020	Axis 32																																																
:	:	:																																																
H 0040	H 8040	Axis 64																																																
H 0041	H 8041	Virtual axis 1																																																
:	:	:																																																
H 0060	H 8060	Virtual axis 32																																																
1	UM 02391	Synchronous output function selected state monitor	H0	<p>Stores the information on the master axis of synchronous control.</p> <table border="1"> <thead> <tr> <th>bit.</th> <th>Name</th> <th>Value</th> </tr> </thead> <tbody> <tr> <td>0</td> <td>Electronic gear operation settings</td> <td rowspan="5">0: Not use 1: Use</td> </tr> <tr> <td>1</td> <td>Clutch operation setting</td> </tr> <tr> <td>2</td> <td>Electronic cam operation setting</td> </tr> <tr> <td>3</td> <td>Advance angle correction operation setting</td> </tr> <tr> <td>15-4</td> <td>-</td> <td>-</td> </tr> </tbody> </table>	bit.	Name	Value	0	Electronic gear operation settings	0: Not use 1: Use	1	Clutch operation setting	2	Electronic cam operation setting	3	Advance angle correction operation setting	15-4	-	-	●	-																													
bit.	Name	Value																																																
0	Electronic gear operation settings	0: Not use 1: Use																																																
1	Clutch operation setting																																																	
2	Electronic cam operation setting																																																	
3	Advance angle correction operation setting																																																	
15-4	-		-																																															
1	UM 02392 -UM 02395	Reserved for system	-	-	-	-																																												
(2-64 Virtual 1-32)	UM 02396 -UM 025CF	<p>As well as the area for axis 1, 6-word area is allocated to each axis in the following configuration.</p> <ul style="list-style-type: none"> <li>● Synchronous master axis information monitor area: 1 word</li> <li>● Synchronous output function selected state monitor area: 1 word</li> <li>● Reserved area for the system: 4 words</li> </ul>		●	-																																													
-	UM 025D0 -UM 0260F	Reserved for system	-	-	-	-																																												

16.5.13 System Operation Setting Area

●: Available, -: Not available

Axis no.	Unit memory no. (Hex)	Name	Default	Description	R	W
-	UM 0261D	Deceleration stop operation	H0	<p>Specify the operation when setting the deceleration stop request signal to "Active" (from off to on).</p> <p>0: Deceleration stop</p> <p>When performing the repeat operation, stops after reaching E-point that is targeted for the repeat operation.</p> <p>1: Pause</p> <ul style="list-style-type: none"> <li>Performs the deceleration stop, and restarts the positioning operation when turning "Deceleration stop request signal" to off from on.</li> <li>Also, performs the same operation as the deceleration stop in all states except during the positioning operation.</li> <li>When performing the repeat operation, stops after reaching E-point that is targeted for the repeat operation, and restarts the positioning operation when turning "Deceleration stop request signal" to off from on.</li> <li>If a system stop or emergency stop is executed while the positioning unit is paused, the pause state will be canceled and the operation will not restart with the deceleration stop request signal is canceled (turned off).</li> </ul>	●	●

## 16.5.14 Time Chart Function Operation Setting/Annunciation Area

●: Available, -: Not available

Axis no.	Unit memory no. (Hex)	Name	Default	Description	R	W																																				
-	UM 02630	Announce trigger registration	H0	<p>The trigger numbers registered in FP7 MC Unit turn on.</p> <table border="1"> <thead> <tr> <th>bit.</th> <th>Name</th> <th>Description</th> </tr> </thead> <tbody> <tr><td>0</td><td>Trigger no. 1</td><td rowspan="16">0: Not registered 1: Trigger condition is registered.</td></tr> <tr><td>1</td><td>Trigger no. 2</td></tr> <tr><td>2</td><td>Trigger no. 3</td></tr> <tr><td>3</td><td>Trigger no. 4</td></tr> <tr><td>4</td><td>Trigger no. 5</td></tr> <tr><td>5</td><td>Trigger no. 6</td></tr> <tr><td>6</td><td>Trigger no. 7</td></tr> <tr><td>7</td><td>Trigger no. 8</td></tr> <tr><td>8</td><td>Trigger no. 9</td></tr> <tr><td>9</td><td>Trigger no. 10</td></tr> <tr><td>10</td><td>Trigger no. 11</td></tr> <tr><td>11</td><td>Trigger no. 12</td></tr> <tr><td>12</td><td>Trigger no. 13</td></tr> <tr><td>13</td><td>Trigger no. 14</td></tr> <tr><td>14</td><td>Trigger no. 15</td></tr> <tr><td>15</td><td>Trigger no. 16</td></tr> </tbody> </table>	bit.	Name	Description	0	Trigger no. 1	0: Not registered 1: Trigger condition is registered.	1	Trigger no. 2	2	Trigger no. 3	3	Trigger no. 4	4	Trigger no. 5	5	Trigger no. 6	6	Trigger no. 7	7	Trigger no. 8	8	Trigger no. 9	9	Trigger no. 10	10	Trigger no. 11	11	Trigger no. 12	12	Trigger no. 13	13	Trigger no. 14	14	Trigger no. 15	15	Trigger no. 16	●	-
bit.	Name	Description																																								
0	Trigger no. 1	0: Not registered 1: Trigger condition is registered.																																								
1	Trigger no. 2																																									
2	Trigger no. 3																																									
3	Trigger no. 4																																									
4	Trigger no. 5																																									
5	Trigger no. 6																																									
6	Trigger no. 7																																									
7	Trigger no. 8																																									
8	Trigger no. 9																																									
9	Trigger no. 10																																									
10	Trigger no. 11																																									
11	Trigger no. 12																																									
12	Trigger no. 13																																									
13	Trigger no. 14																																									
14	Trigger no. 15																																									
15	Trigger no. 16																																									
-	UM 02631	Allow trigger use	H0	<p>The control for using triggers is set.</p> <table border="1"> <thead> <tr> <th>bit.</th> <th>Name</th> <th>Description</th> </tr> </thead> <tbody> <tr><td>0</td><td>Trigger no. 1</td><td rowspan="16">0: Not allow the use. 1: Allow the use.</td></tr> <tr><td>1</td><td>Trigger no. 2</td></tr> <tr><td>2</td><td>Trigger no. 3</td></tr> <tr><td>3</td><td>Trigger no. 4</td></tr> <tr><td>4</td><td>Trigger no. 5</td></tr> <tr><td>5</td><td>Trigger no. 6</td></tr> <tr><td>6</td><td>Trigger no. 7</td></tr> <tr><td>7</td><td>Trigger no. 8</td></tr> <tr><td>8</td><td>Trigger no. 9</td></tr> <tr><td>9</td><td>Trigger no. 10</td></tr> <tr><td>10</td><td>Trigger no. 11</td></tr> <tr><td>11</td><td>Trigger no. 12</td></tr> <tr><td>12</td><td>Trigger no. 13</td></tr> <tr><td>13</td><td>Trigger no. 14</td></tr> <tr><td>14</td><td>Trigger no. 15</td></tr> <tr><td>15</td><td>Trigger no. 16</td></tr> </tbody> </table>	bit.	Name	Description	0	Trigger no. 1	0: Not allow the use. 1: Allow the use.	1	Trigger no. 2	2	Trigger no. 3	3	Trigger no. 4	4	Trigger no. 5	5	Trigger no. 6	6	Trigger no. 7	7	Trigger no. 8	8	Trigger no. 9	9	Trigger no. 10	10	Trigger no. 11	11	Trigger no. 12	12	Trigger no. 13	13	Trigger no. 14	14	Trigger no. 15	15	Trigger no. 16	●	●
bit.	Name	Description																																								
0	Trigger no. 1	0: Not allow the use. 1: Allow the use.																																								
1	Trigger no. 2																																									
2	Trigger no. 3																																									
3	Trigger no. 4																																									
4	Trigger no. 5																																									
5	Trigger no. 6																																									
6	Trigger no. 7																																									
7	Trigger no. 8																																									
8	Trigger no. 9																																									
9	Trigger no. 10																																									
10	Trigger no. 11																																									
11	Trigger no. 12																																									
12	Trigger no. 13																																									
13	Trigger no. 14																																									
14	Trigger no. 15																																									
15	Trigger no. 16																																									

# Specifications

●: Available, -: Not available

Axis no.	Unit memory no. (Hex)	Name	Default	Description	R	W																																				
-	UM 02632	Logging flag	H0	<p>The logging state is stored. When FP7 MC Unit detects trigger conditions, the corresponding bits turn on.</p> <table border="1"> <thead> <tr> <th>bit.</th> <th>Name</th> <th>Description</th> </tr> </thead> <tbody> <tr><td>0</td><td>Trigger no. 1</td><td rowspan="16">0: Logging is not executed/complete 1: During logging</td></tr> <tr><td>1</td><td>Trigger no. 2</td></tr> <tr><td>2</td><td>Trigger no. 3</td></tr> <tr><td>3</td><td>Trigger no. 4</td></tr> <tr><td>4</td><td>Trigger no. 5</td></tr> <tr><td>5</td><td>Trigger no. 6</td></tr> <tr><td>6</td><td>Trigger no. 7</td></tr> <tr><td>7</td><td>Trigger no. 8</td></tr> <tr><td>8</td><td>Trigger no. 9</td></tr> <tr><td>9</td><td>Trigger no. 10</td></tr> <tr><td>10</td><td>Trigger no. 11</td></tr> <tr><td>11</td><td>Trigger no. 12</td></tr> <tr><td>12</td><td>Trigger no. 13</td></tr> <tr><td>13</td><td>Trigger no. 14</td></tr> <tr><td>14</td><td>Trigger no. 15</td></tr> <tr><td>15</td><td>Trigger no. 16</td></tr> </tbody> </table>	bit.	Name	Description	0	Trigger no. 1	0: Logging is not executed/complete 1: During logging	1	Trigger no. 2	2	Trigger no. 3	3	Trigger no. 4	4	Trigger no. 5	5	Trigger no. 6	6	Trigger no. 7	7	Trigger no. 8	8	Trigger no. 9	9	Trigger no. 10	10	Trigger no. 11	11	Trigger no. 12	12	Trigger no. 13	13	Trigger no. 14	14	Trigger no. 15	15	Trigger no. 16	●	-
bit.	Name	Description																																								
0	Trigger no. 1	0: Logging is not executed/complete 1: During logging																																								
1	Trigger no. 2																																									
2	Trigger no. 3																																									
3	Trigger no. 4																																									
4	Trigger no. 5																																									
5	Trigger no. 6																																									
6	Trigger no. 7																																									
7	Trigger no. 8																																									
8	Trigger no. 9																																									
9	Trigger no. 10																																									
10	Trigger no. 11																																									
11	Trigger no. 12																																									
12	Trigger no. 13																																									
13	Trigger no. 14																																									
14	Trigger no. 15																																									
15	Trigger no. 16																																									
-	UM 02633	Presence/absence of logging data	H0	<p>When logging is executed and logging data is stored, the bits corresponding to trigger number turn on.</p> <table border="1"> <thead> <tr> <th>bit.</th> <th>Name</th> <th>Description</th> </tr> </thead> <tbody> <tr><td>0</td><td>Trigger no. 1</td><td rowspan="16">0: No logging data 1: Logging data exists.</td></tr> <tr><td>1</td><td>Trigger no. 2</td></tr> <tr><td>2</td><td>Trigger no. 3</td></tr> <tr><td>3</td><td>Trigger no. 4</td></tr> <tr><td>4</td><td>Trigger no. 5</td></tr> <tr><td>5</td><td>Trigger no. 6</td></tr> <tr><td>6</td><td>Trigger no. 7</td></tr> <tr><td>7</td><td>Trigger no. 8</td></tr> <tr><td>8</td><td>Trigger no. 9</td></tr> <tr><td>9</td><td>Trigger no. 10</td></tr> <tr><td>10</td><td>Trigger no. 11</td></tr> <tr><td>11</td><td>Trigger no. 12</td></tr> <tr><td>12</td><td>Trigger no. 13</td></tr> <tr><td>13</td><td>Trigger no. 14</td></tr> <tr><td>14</td><td>Trigger no. 15</td></tr> <tr><td>15</td><td>Trigger no. 16</td></tr> </tbody> </table>	bit.	Name	Description	0	Trigger no. 1	0: No logging data 1: Logging data exists.	1	Trigger no. 2	2	Trigger no. 3	3	Trigger no. 4	4	Trigger no. 5	5	Trigger no. 6	6	Trigger no. 7	7	Trigger no. 8	8	Trigger no. 9	9	Trigger no. 10	10	Trigger no. 11	11	Trigger no. 12	12	Trigger no. 13	13	Trigger no. 14	14	Trigger no. 15	15	Trigger no. 16	●	-
bit.	Name	Description																																								
0	Trigger no. 1	0: No logging data 1: Logging data exists.																																								
1	Trigger no. 2																																									
2	Trigger no. 3																																									
3	Trigger no. 4																																									
4	Trigger no. 5																																									
5	Trigger no. 6																																									
6	Trigger no. 7																																									
7	Trigger no. 8																																									
8	Trigger no. 9																																									
9	Trigger no. 10																																									
10	Trigger no. 11																																									
11	Trigger no. 12																																									
12	Trigger no. 13																																									
13	Trigger no. 14																																									
14	Trigger no. 15																																									
15	Trigger no. 16																																									
-	UM 02634 -UM 02637	Reserved for system																																								

## 16.5.15 ESM Switch Control Area

●: Available, -: Not available

Axis no.	Unit memory no. (Hex)	Name	Default	Description	R	W						
-	UM 02638	Switch request ESM	H0	Specify the mode of ESM switch request. <table border="1"> <thead> <tr> <th>bit.</th> <th>Name</th> <th>Description</th> </tr> </thead> <tbody> <tr> <td>15-0</td> <td>Switch request ESM</td> <td>0001H: Int 0002H: PreOP 0004H: SafeOP 0008H: OP</td> </tr> </tbody> </table>	bit.	Name	Description	15-0	Switch request ESM	0001H: Int 0002H: PreOP 0004H: SafeOP 0008H: OP	●	●
bit.	Name	Description										
15-0	Switch request ESM	0001H: Int 0002H: PreOP 0004H: SafeOP 0008H: OP										
-	UM 02639	Switched node address	U0	Set a node address to be switched. Range: 0 to 192 Any other settings will be errors.	●	●						
-	UM 0263A	Timeout value	U100	Set the timeout monitor time. Range: 0 to 10000 Any other settings will be errors.	●	●						
-	UM 0263B	Result	H0	The execution result of ESM switch request is stored. <table border="1"> <thead> <tr> <th>bit.</th> <th>Name</th> <th>Description</th> </tr> </thead> <tbody> <tr> <td>15-0</td> <td>Result</td> <td>0001H: Normal end 5555H: In progress FFFFH: Error occurs</td> </tr> </tbody> </table>	bit.	Name	Description	15-0	Result	0001H: Normal end 5555H: In progress FFFFH: Error occurs	●	-
bit.	Name	Description										
15-0	Result	0001H: Normal end 5555H: In progress FFFFH: Error occurs										
-	UM 0263C	Error code	H0	Error codes are stored. <table border="1"> <thead> <tr> <th>bit.</th> <th>Name</th> <th>Description</th> </tr> </thead> <tbody> <tr> <td>15-0</td> <td>Error code</td> <td>0001H: Address specification error 0002H: ESM setting values error 0006H: Timeout error</td> </tr> </tbody> </table>	bit.	Name	Description	15-0	Error code	0001H: Address specification error 0002H: ESM setting values error 0006H: Timeout error	●	-
bit.	Name	Description										
15-0	Error code	0001H: Address specification error 0002H: ESM setting values error 0006H: Timeout error										
-	UM 0263D -UM 0263F	Reserved for system	-	-	-	-						

## 16.6 Unit Memories (Each Axis Information Area)

### 16.6.1 Configuration of Each Axis Information Area

UM 0000	Whole unit memory map	
UM 0007F UM 00080	System area 128 words	UM 02640 Information and monitor area of 1st axis 32 words
UM 0017F UM 00180	Input control area 256 words	UM 02660 Information and monitor area of 2nd axis 32 words
UM 0027F UM 00280	Output control area 256 words	:::
	Common area 9,104 words	UM 02820 Information and monitor area of 16th axis 32 words
		:::
		UM 02A20 Information and monitor area of 32th axis 32 words
		:::
UM 0260F UM 02610	System area 48 words	UM 02C20 Information and monitor area of 48th axis 32 words
UM 0263F UM 02640	Each axis information area 3,072 words	:::
UM 0323F UM 03240		UM 02E20 Information and monitor area of 64th axis 32 words
	Each axis setting area 396,480 words	UM 02E40 Information and monitor area of virtual 1st axis 32 words
		:::
		UM 03020 Information and monitor area of virtual 16th axis 32 words
		:::
		UM 03220 Information and monitor area of virtual 32th axis 32 words
UM 63EFF UM 63F00	System area 64 words	
UM 63F3F UM 63F40	Synchronous control setting area 10,752 words	
UM 6693F UM 66940	Positioning operation change setting area 1,536 words	
UM 66F3F UM 66F40	Cam pattern editing area 106 words	

16.6.2 Each Axis Information & Monitor Area

●: Available, -: Not available

Axis no.	Unit memory no. (Hex)	Name	Default	Description	R	W																											
1	UM 02640 -UM 02641	Vender ID	H0	Stores the ID code corresponding to brand name or vendor name. It is stored as 4 bytes.	●	-																											
1	UM 02642 -UM 02643	Product Code	H0	Stores the model code of AMP. It is stored as 4 bytes.	●	-																											
1	UM 02644 -UM 02645	Revision no.	H0	Stores the firmware version of AMP. It is stored as 4 bytes.	●	-																											
1	UM 02646 -UM 02647	Serial no.	H0	Stores the serial number of AMP. It is stored as 4 bytes.	●	-																											
1	UM 02648	Station Address:	H0	Stores the station address set to AMP. It is stored as 4 bytes.	●	-																											
1	UM 02649	Reserved for system	-	-	-	-																											
1	UM 0264A	AMP status display	H0	<p>Stores the status of AMP.</p> <table border="1"> <thead> <tr> <th>bit.</th> <th>Name</th> <th>Value</th> </tr> </thead> <tbody> <tr> <td>1-0</td> <td>Reserved for system</td> <td>-</td> </tr> <tr> <td>2</td> <td>Home return done</td> <td>0: Home return not completed 1: Home return completed</td> </tr> <tr> <td>3</td> <td>Torque limit</td> <td>0: Normal detection 1: Contact detection (Torque limit)</td> </tr> <tr> <td>4</td> <td>Warning</td> <td>0: Normal 1: Warning occurred</td> </tr> <tr> <td>5</td> <td>Alarm</td> <td>0: Normal 1: Alarm occurred</td> </tr> <tr> <td>6</td> <td>Servo ready</td> <td>0: Cannot shift to the servo on-state. 1: Servo ready</td> </tr> <tr> <td>7</td> <td>Servo active</td> <td>0: Servo off 1: Servo on</td> </tr> <tr> <td>15-8</td> <td>Reserved for system</td> <td>-</td> </tr> </tbody> </table>	bit.	Name	Value	1-0	Reserved for system	-	2	Home return done	0: Home return not completed 1: Home return completed	3	Torque limit	0: Normal detection 1: Contact detection (Torque limit)	4	Warning	0: Normal 1: Warning occurred	5	Alarm	0: Normal 1: Alarm occurred	6	Servo ready	0: Cannot shift to the servo on-state. 1: Servo ready	7	Servo active	0: Servo off 1: Servo on	15-8	Reserved for system	-	●	-
bit.	Name	Value																															
1-0	Reserved for system	-																															
2	Home return done	0: Home return not completed 1: Home return completed																															
3	Torque limit	0: Normal detection 1: Contact detection (Torque limit)																															
4	Warning	0: Normal 1: Warning occurred																															
5	Alarm	0: Normal 1: Alarm occurred																															
6	Servo ready	0: Cannot shift to the servo on-state. 1: Servo ready																															
7	Servo active	0: Servo off 1: Servo on																															
15-8	Reserved for system	-																															

## Specifications

●: Available, -: Not available

Axis no.	Unit memory no. (Hex)	Name	Default	Description	R	W																							
1	UM 0264B	External input terminal monitor	H0	<p>Stores the statuses of input terminals connected to each axis.</p> <table border="1"> <thead> <tr> <th>bit.</th> <th>Name</th> <th>Value</th> </tr> </thead> <tbody> <tr> <td>0</td> <td>NOT</td> <td rowspan="8">0: Non active 1: Active</td> </tr> <tr> <td>1</td> <td>POT</td> </tr> <tr> <td>2</td> <td>HOME</td> </tr> <tr> <td>3</td> <td>SI-MON1 / EXT1</td> </tr> <tr> <td>4</td> <td>SI-MON2 / EXT2</td> </tr> <tr> <td>5</td> <td>SI-MON3</td> </tr> <tr> <td>6</td> <td>SI-MON4</td> </tr> <tr> <td>7</td> <td>SI-MON5/ E-STOP</td> </tr> <tr> <td>15-8</td> <td>-</td> <td>-</td> </tr> </tbody> </table>	bit.	Name	Value	0	NOT	0: Non active 1: Active	1	POT	2	HOME	3	SI-MON1 / EXT1	4	SI-MON2 / EXT2	5	SI-MON3	6	SI-MON4	7	SI-MON5/ E-STOP	15-8	-	-	●	-
bit.	Name	Value																											
0	NOT	0: Non active 1: Active																											
1	POT																												
2	HOME																												
3	SI-MON1 / EXT1																												
4	SI-MON2 / EXT2																												
5	SI-MON3																												
6	SI-MON4																												
7	SI-MON5/ E-STOP																												
15-8	-	-																											
1	UM 0264C	Torque monitor value	-	Stores the torque monitor value as integer. Range: 0 to 5000 (0.0 % to 500.0 %)	●	-																							
1	UM 0264D	Actual speed monitor value	-	Stores the actual speed monitor value/ Range: 0 to 5000 (rpm) When "Extend monitor value" in MC common settings is set to "2 words", this area is "0".	●	-																							
1	UM 0264E -UM 0264F	Position deviation	-	Stores the difference value between the value of the position specified in FP7 MC Unit and the value of the position fed back from the amplifier.	●	-																							
1	UM 02650	Active or execution done table	U1	Stores the number of active positioning table or when the operation completed. Range: Standard area: 1 to 1000 Expansion area: 10,001 to 10,100	●	-																							
1	UM 02651	Auxiliary output code	U0	Stores the auxiliary output code when the auxiliary output function is enabled by the axis parameter.	●	-																							
1	UM 02652	Repeat count current value	U0	Stores the repeat count during the positioning operation. Stores 1 when no repeat operation is performed. Returns to 0 when the repeat count exceeds the upper limit. Range: 0 to 65535 [times]	●	-																							
1	UM 02653	Reserved for system	-	-	-	-																							



## 16.6 Unit Memories (Each Axis Information Area)

●: Available, -: Not available

Axis no.	Unit memory no. (Hex)	Name	Default	Description	R	W																																																
1	UM 02654 -UM 02655	AMP current value [Absolute coordinate]	K0	Stores the current value based on a mechanical origin in pulse units. It will be reset to "0" on the completion of home return. The value will not be updated when the current value update function is executed.  Unit: pulse	●	-																																																
1	UM 02656 -UM 02657	Current value after unit conversion [Logic system coordinate]	K0	Stores the current value based on an electric origin (value set as home position coordinate). Stores values converted with the unit system (pulse, μm, inch, degree) selected in the axis parameter as integer.  When the home return is completed, the value set as home position coordinate will be stored. When "0" is set as home position coordinate, it will be reset to "0".  This area is also updated when the current value update function is used.	●	-																																																
1	UM 02658	Control mode current value	-	Stores the current control mode. H0: Positioning control (E-point control / P-point control / C-point control) H1: J-point control H2: Home return H3: JOG operation (Operating motion) H4: JOG operation (Inching motion)	●	-																																																
1	UM 02659 -UM 0265B	Reserved for system	-	-	-	-																																																
1	UM 0265C -UM 0265D	Current advance angle correction amount	K0	Stores the current advance angle correction amount.  Range: -2,147,483,648 to 2,147,483,647	●	-																																																
1	UM 0265E -UM 0265F	Reserved for system	-	-	-	-																																																
(2-64 Virtual 1-32)	UM 2660 -UM 323F	As well as the area for axis 1, 32-word area is allocated to each axis in the following configuration.		<table border="1" style="width: 100%; border-collapse: collapse;"> <thead> <tr> <th style="text-align: center;">Item</th> <th style="text-align: center;">No. of words</th> <th style="text-align: center;">Item</th> <th style="text-align: center;">No. of words</th> </tr> </thead> <tbody> <tr> <td>Vender ID</td> <td style="text-align: center;">2 words</td> <td>Position deviation</td> <td style="text-align: center;">2 words</td> </tr> <tr> <td>Product Code</td> <td style="text-align: center;">2 words</td> <td>Active or execution done table</td> <td style="text-align: center;">1 word</td> </tr> <tr> <td>Revision no.</td> <td style="text-align: center;">2 words</td> <td>Auxiliary output code</td> <td style="text-align: center;">1 word</td> </tr> <tr> <td>Serial no.</td> <td style="text-align: center;">2 words</td> <td>Repeat count current value</td> <td style="text-align: center;">1 word</td> </tr> <tr> <td>Station address</td> <td style="text-align: center;">1 word</td> <td>Reserved for system</td> <td style="text-align: center;">1 word</td> </tr> <tr> <td>Reserved for system</td> <td style="text-align: center;">1 word</td> <td>AMP current value</td> <td style="text-align: center;">2 words</td> </tr> <tr> <td>AMP status display</td> <td style="text-align: center;">1 word</td> <td>Unit system conversion current value</td> <td style="text-align: center;">2 words</td> </tr> <tr> <td>External input terminal monitor</td> <td style="text-align: center;">1 word</td> <td>Control mode current value</td> <td style="text-align: center;">1 word</td> </tr> <tr> <td>Torque monitor value</td> <td style="text-align: center;">1 word</td> <td>Reserved area for the system</td> <td style="text-align: center;">3 words</td> </tr> <tr> <td>Actual speed monitor value</td> <td style="text-align: center;">1 word</td> <td>Current advance angle correction amount</td> <td style="text-align: center;">2 words</td> </tr> <tr> <td></td> <td></td> <td>Reserved area for the system</td> <td style="text-align: center;">2 words</td> </tr> </tbody> </table>	Item	No. of words	Item	No. of words	Vender ID	2 words	Position deviation	2 words	Product Code	2 words	Active or execution done table	1 word	Revision no.	2 words	Auxiliary output code	1 word	Serial no.	2 words	Repeat count current value	1 word	Station address	1 word	Reserved for system	1 word	Reserved for system	1 word	AMP current value	2 words	AMP status display	1 word	Unit system conversion current value	2 words	External input terminal monitor	1 word	Control mode current value	1 word	Torque monitor value	1 word	Reserved area for the system	3 words	Actual speed monitor value	1 word	Current advance angle correction amount	2 words			Reserved area for the system	2 words	●	-
Item	No. of words	Item	No. of words																																																			
Vender ID	2 words	Position deviation	2 words																																																			
Product Code	2 words	Active or execution done table	1 word																																																			
Revision no.	2 words	Auxiliary output code	1 word																																																			
Serial no.	2 words	Repeat count current value	1 word																																																			
Station address	1 word	Reserved for system	1 word																																																			
Reserved for system	1 word	AMP current value	2 words																																																			
AMP status display	1 word	Unit system conversion current value	2 words																																																			
External input terminal monitor	1 word	Control mode current value	1 word																																																			
Torque monitor value	1 word	Reserved area for the system	3 words																																																			
Actual speed monitor value	1 word	Current advance angle correction amount	2 words																																																			
		Reserved area for the system	2 words																																																			

## 16.7 Unit Memories (Each Axis Setting Area)

### 16.7.1 Configuration of Each Axis Setting Area

Whole unit memory map	
UM 00000	System area
UM 0007F UM 00080	128 words
UM 0017F UM 00180	Input control area
UM 0027F UM 00280	256 words
UM 0027F UM 00280	Output control area
UM 0027F UM 00280	256 words
UM 0260F UM 02610	Common area
UM 0260F UM 02610	9,104 words
UM 0260F UM 02610	System area
UM 0260F UM 02610	48 words
UM 0263F UM 02640	Each axis information area
UM 0263F UM 02640	3,072 words
UM 0323F UM 03240	Starting no. Name
UM 0323F UM 03240	No. of words
UM 0323F UM 03240	UM 03240 Parameter setting area
UM 0323F UM 03240	12,288 words
UM 0323F UM 03240	Each axis setting area
UM 0323F UM 03240	396,480 words
UM 0323F UM 03240	UM 06240 Positioning data setting area
UM 0323F UM 03240	384,192 words
UM 63EFF UM 63F00	System area
UM 63EFF UM 63F00	64 words
UM 63F3F UM 63F40	Synchronous control setting area
UM 63F3F UM 63F40	10,752 words
UM 6693F UM 66940	Positioning operation change setting area
UM 6693F UM 66940	1,536 words
UM 66F3F UM 66F40	Cam pattern editing area
UM 66F3F UM 66F40	106 words

16.7.2 Configuration of Parameter Setting Area

Whole unit memory map

UM 00000	System area	128 words
UM 0007F UM 00080	Input control area	256 words
UM 0017F UM 00180	Output control area	256 words
UM 0027F UM 00280	Common area	9,104 words
UM 0260F UM 02610	System area	48 words
UM 0263F UM 02640	Each axis information area	3,072 words
UM 0323F UM 03240	Each axis setting area	396,480 words
UM 63EFF UM 63F00	System area	64 words
UM 63F3F UM 63F40	Synchronous control setting area	10,752 words
UM 6693F UM 66940	Positioning operation change setting area	1,536 words
UM 66F3F UM 66F40	Cam pattern editing area	106 words

UM 03240	Parameter setting area	12,288 words
UM 0623F UM 06240	Positioning data setting area	384,192 words
UM 63EFF		

Starting no.	Name	No. of words
UM 03240	Parameter setting area of 1st axis	128 words
UM 032C0	Parameter setting area of 2nd axis	128 words
UM 039C0	Parameter setting area of 16th axis	128 words
	::	
UM 041C0	Parameter setting area of 32th axis	128 words
	::	
UM 049C0	Parameter setting area of 48th axis	128 words
	::	
UM 051C0	Parameter setting area of 64th axis	128 words
UM 05240	Parameter setting area of virtual 1st axis	128 words
	::	
UM 059C0	Parameter setting area of virtual 16th axis	128 words
	::	
UM 061C0	Parameter setting area of virtual 32th axis	128 words

### 16.7.3 Parameter Setting Area

The following table shows the unit memory numbers of axis number 1. 128-word area is allocated to each axis.

●: Available, -: Not available

Axis no.	Unit memory no. (Hex)	Name	Default	Description	R	W
1	UM 03240	Unit setting	H0	Set the unit system of movement amounts of the positioning control for each axis. The same unit system should be set for all interpolation axes. H0: pulse H100: $\mu\text{m}$ (0.1 $\mu\text{m}$ ) H101: $\mu\text{m}$ (1 $\mu\text{m}$ ) H200: inch (0.00001 inch) H201: inch (0.0001 inch) H300: degree (0.1 degree) H301: degree (1 degree) Any other settings will be errors.	●	●
1	UM 03241	Reserved for system	-	-	-	-
1	UM 03242 -UM 03243	Number of pulses per revolution	U1	Set the pulse number per revolution. It is necessary for the conversion of the pulse number when the unit is $\mu\text{m}$ , inch or degree. Range: 1 to 2,147,483,647 Any other settings will be errors.	●	●
1	UM 03244 -UM 03245	Movement per revolution	U1	Set the movement amount per revolution. It is necessary for the conversion of the pulse number when the unit is $\mu\text{m}$ , inch or degree. Range: 1 to 32,767,000 Any other settings will be errors. The ranges vary depending on the unit settings as below. $\mu\text{m}$ : 1 $\mu\text{m}$ inch: 1/10,000 inch degree: 1 degree	●	●
1	UM 03246 -UM 03249	Reserved for system	-	-	-	-
1	UM 0324A	Movement check operation	U2	Set the operation to be performed when the difference between the command value and feedback value exceeds the moving amount check value. 0: Error If the difference between the feedback value and the command moving amount exceeded the moving amount check value (threshold), an error occurs. 1: Warning If the difference between the feedback value and the command moving amount exceeded the moving amount check value (threshold), a warning occurs. 2: None The moving amount check is not performed.	●	●

●: Available, -: Not available

## 16.7 Unit Memories (Each Axis Setting Area)

Axis no.	Unit memory no. (Hex)	Name	Default	Description	R	W													
1	UM 0324B	Software limit enabled/disabled	H0	<p>Select whether to enable or disable the software limit for each control.</p> <table border="1"> <thead> <tr> <th>bit</th> <th>Name</th> <th>Description</th> </tr> </thead> <tbody> <tr> <td>0</td> <td>Software limit (Positioning control)</td> <td rowspan="3">0: Disable 1: Enable</td> </tr> <tr> <td>1</td> <td>Software limit (Home return)</td> </tr> <tr> <td>2</td> <td>Software limit (JOG operation)</td> </tr> <tr> <td>15-3</td> <td>—</td> <td>—</td> </tr> </tbody> </table>	bit	Name	Description	0	Software limit (Positioning control)	0: Disable 1: Enable	1	Software limit (Home return)	2	Software limit (JOG operation)	15-3	—	—	●	●
bit	Name	Description																	
0	Software limit (Positioning control)	0: Disable 1: Enable																	
1	Software limit (Home return)																		
2	Software limit (JOG operation)																		
15-3	—	—																	
1	UM 0324C -UM 0324D	Software limit Upper limit value	K21474836 47	<p>Set the upper and lower limits of the software limit for absolute coordinates.</p> <p>The ranges vary depending on the unit settings as below.</p> <p>pulse: -2,147,483,648 to 2,147,483,647 pulses  <math>\mu\text{m}</math> (0.1<math>\mu\text{m}</math>): -214,748,364.8 to 214,748,364.7 <math>\mu\text{m}</math>  <math>\mu\text{m}</math> (1<math>\mu\text{m}</math>): -2,147,483,648 to 2,147,483,647<math>\mu\text{m}</math>  inch (0.00001 inch): -21,474.83648 to 21,474.83647 inches  inch (0.0001 inch): -214,748.3648 to 214,748.3647 inches  degree (0.1 degree): -214,748,364.8 to 214,748,364.7 degrees  degree (1 degree): -2,147,483,648 to 2,147,483,647 degrees</p> <p>Any other settings will be errors.</p>	●	●													
1	UM 0324E -UM 0324F	Software limit Lower limit value	K-2147483 648	<p>Set the upper and lower limits of the software limit for absolute coordinates.</p> <p>The ranges vary depending on the unit settings as below.</p> <p>pulse: -2,147,483,648 to 2,147,483,647 pulses  <math>\mu\text{m}</math> (0.1<math>\mu\text{m}</math>): -214,748,364.8 to 214,748,364.7 <math>\mu\text{m}</math>  <math>\mu\text{m}</math> (1<math>\mu\text{m}</math>): -2,147,483,648 to 2,147,483,647<math>\mu\text{m}</math>  inch (0.00001 inch): -21,474.83648 to 21,474.83647 inches  inch (0.0001 inch): -214,748.3648 to 214,748.3647 inches  degree (0.1 degree): -214,748,364.8 to 214,748,364.7 degrees  degree (1 degree): -2,147,483,648 to 2,147,483,647 degrees</p> <p>Any other settings will be errors.</p>	●	●													
1	UM 03250 -UM 03251	Reserved for system	-	-	-	-													
1	UM 03252	Auxiliary output mode	HA00	<p>Set the auxiliary output mode and the ON time of auxiliary output.</p> <table border="1"> <thead> <tr> <th>bit</th> <th>Name</th> <th>Description</th> </tr> </thead> <tbody> <tr> <td>7-0</td> <td>Auxiliary output mode</td> <td>H0: Not use auxiliary output function H1: Use With mode. H2: Use Delay mode</td> </tr> <tr> <td>15-8</td> <td>Auxiliary output ON time</td> <td>Range: H0 (0 ms) to HFF (255 ms)</td> </tr> </tbody> </table>	bit	Name	Description	7-0	Auxiliary output mode	H0: Not use auxiliary output function H1: Use With mode. H2: Use Delay mode	15-8	Auxiliary output ON time	Range: H0 (0 ms) to HFF (255 ms)	●	●				
bit	Name	Description																	
7-0	Auxiliary output mode	H0: Not use auxiliary output function H1: Use With mode. H2: Use Delay mode																	
15-8	Auxiliary output ON time	Range: H0 (0 ms) to HFF (255 ms)																	
1	UM 03253	Auxiliary output Delay ratio	U0	<p>Set the ratio (%) to the movement amount for starting the output when using the delay mode for the auxiliary output.</p> <p>Range: 0 to 100[%]</p> <p>Example) When it is 50%, the auxiliary output turns on when the movement amount exceeds 50%.</p>	●	●													

# Specifications

●: Available, -: Not available

Axis no.	Unit memory no. (Hex)	Name	Default	Description	R	W																						
1	UM 03254	Operation setting	H31	Configure the settings of limit, moving direction and input logic.	●	●																						
				<table border="1"> <thead> <tr> <th>bit</th> <th>Name</th> <th>Description</th> </tr> </thead> <tbody> <tr> <td>0</td> <td>Limit switch</td> <td>0: Enable 1: Disable</td> </tr> <tr> <td>1</td> <td>CW/CCW direction setting</td> <td>0: Elapsed value + direction is CW 1: Elapsed value + direction is CCW</td> </tr> <tr> <td>2</td> <td>Limit switch connection</td> <td>0: Standard connection 1: Reverse connection</td> </tr> <tr> <td>3</td> <td>Home position proximity logic</td> <td rowspan="3">0: Normal Open 1: Normal Close</td> </tr> <tr> <td>4</td> <td>Limit + Switch logic</td> </tr> <tr> <td>5</td> <td>Limit - Switch logic</td> </tr> <tr> <td>15-6</td> <td>—</td> <td>—</td> </tr> </tbody> </table>			bit	Name	Description	0	Limit switch	0: Enable 1: Disable	1	CW/CCW direction setting	0: Elapsed value + direction is CW 1: Elapsed value + direction is CCW	2	Limit switch connection	0: Standard connection 1: Reverse connection	3	Home position proximity logic	0: Normal Open 1: Normal Close	4	Limit + Switch logic	5	Limit - Switch logic	15-6	—	—
				bit			Name	Description																				
				0			Limit switch	0: Enable 1: Disable																				
				1			CW/CCW direction setting	0: Elapsed value + direction is CW 1: Elapsed value + direction is CCW																				
				2			Limit switch connection	0: Standard connection 1: Reverse connection																				
				3			Home position proximity logic	0: Normal Open 1: Normal Close																				
				4			Limit + Switch logic																					
5	Limit - Switch logic																											
15-6	—	—																										
1	UM 03255 -UM 03256	Reserved for system	-	-	-	-																						
1	UM 03257	Completion width check time	U0	Specify the width of the completion of command operation. Range: 0 to 10,000 (ms) Any other settings will be errors. When "0" is set, the completion width is not checked.	●	●																						
1	UM 03258 -UM 03259	Movement check value (pulse)	U10000	Set the threshold for using the movement automatic check function.	●	●																						
				<table border="1"> <thead> <tr> <th>Extend monitor value (Note 1)</th> <th>Range</th> </tr> </thead> <tbody> <tr> <td>1 word</td> <td>0 to 65,535 (pulse)</td> </tr> <tr> <td>2 words</td> <td>0 to 2,147,483,647 (pulse)</td> </tr> </tbody> </table>			Extend monitor value (Note 1)	Range	1 word	0 to 65,535 (pulse)	2 words	0 to 2,147,483,647 (pulse)																
				Extend monitor value (Note 1)			Range																					
1 word	0 to 65,535 (pulse)																											
2 words	0 to 2,147,483,647 (pulse)																											
1	UM 0325A -UM 0325B	Completion width	U10	Turns on the completion flag when the AMP current value [feedback value] becomes within this completion width after the movement of a set amount during the positioning control, JOG operation. Range: 1 to 2,147,483,647 Any other settings will be errors.	●	●																						

(Note 1): The extension to the monitor value of 2 words is available since FP7 MC Unit Ver.1.20. It is set by changing "Extend monitor value" in MC common settings of CMI configuration to "2 words".

## 16.7 Unit Memories (Each Axis Setting Area)

●: Available, -: Not available

Axis no.	Unit memory no. (Hex)	Name	Default	Description	R	W																					
1	UM 0325C	Monitor value error setting	H0	The judgement values for torque monitor values and execution speed of each axis can be set to announce errors or warnings.	●	●																					
				<table border="1" style="width: 100%; border-collapse: collapse;"> <thead> <tr> <th style="text-align: center;">bit</th> <th style="text-align: center;">Name</th> <th style="text-align: center;">Description</th> </tr> </thead> <tbody> <tr> <td style="text-align: center;">0</td> <td>Torque judgment enabled</td> <td>0: Disables the torque judgment value. 1: Enables the torque judgment value.</td> </tr> <tr> <td style="text-align: center;">1</td> <td>Torque judgment value error/warning setting</td> <td>0: Announces an error when it is enabled. 1: Announces a warning when it is enabled.</td> </tr> <tr> <td style="text-align: center;">2</td> <td>Actual speed judgment value enabled</td> <td>0: Disables the actual speed judgment value. 1: Enables the actual speed judgment value.</td> </tr> <tr> <td style="text-align: center;">3</td> <td>Actual speed judgment value error/warning setting</td> <td>0: Announces an error when it is enabled. 1: Announces a warning when it is enabled.</td> </tr> <tr> <td style="text-align: center;">4</td> <td>Actual speed judgement (unit)</td> <td>0: 0.1 rpm 1: Command unit/s</td> </tr> <tr> <td style="text-align: center;">15-5</td> <td style="text-align: center;">—</td> <td style="text-align: center;">—</td> </tr> </tbody> </table>			bit	Name	Description	0	Torque judgment enabled	0: Disables the torque judgment value. 1: Enables the torque judgment value.	1	Torque judgment value error/warning setting	0: Announces an error when it is enabled. 1: Announces a warning when it is enabled.	2	Actual speed judgment value enabled	0: Disables the actual speed judgment value. 1: Enables the actual speed judgment value.	3	Actual speed judgment value error/warning setting	0: Announces an error when it is enabled. 1: Announces a warning when it is enabled.	4	Actual speed judgement (unit)	0: 0.1 rpm 1: Command unit/s	15-5	—	—
				bit			Name	Description																			
				0			Torque judgment enabled	0: Disables the torque judgment value. 1: Enables the torque judgment value.																			
				1			Torque judgment value error/warning setting	0: Announces an error when it is enabled. 1: Announces a warning when it is enabled.																			
				2			Actual speed judgment value enabled	0: Disables the actual speed judgment value. 1: Enables the actual speed judgment value.																			
				3			Actual speed judgment value error/warning setting	0: Announces an error when it is enabled. 1: Announces a warning when it is enabled.																			
4	Actual speed judgement (unit)	0: 0.1 rpm 1: Command unit/s																									
15-5	—	—																									
1	UM 0325D	Torque judgement value	U5000	Set the limit of the torque as integer. Range: 0 to 5000 (0.0% to 500.0%) Any other settings will be errors.	●	●																					
1	UM 0325E -UM 0325F	Actual speed judgement value	U5000	Set the limit of the actual speed as integer.	●	●																					
				<table border="1" style="width: 100%; border-collapse: collapse;"> <thead> <tr> <th style="text-align: center;">Extend monitor value (Note 2)</th> <th style="text-align: center;">Monitor error unit (Note 1)</th> <th style="text-align: center;">Range</th> </tr> </thead> <tbody> <tr> <td rowspan="2" style="text-align: center;">1 words</td> <td style="text-align: center;">1 rpm</td> <td style="text-align: center;">0 to 5000 rpm</td> </tr> <tr> <td style="text-align: center;">0.1 rpm</td> <td style="text-align: center;">0 to 6,500.0 rpm</td> </tr> <tr> <td rowspan="2" style="text-align: center;">2 words</td> <td style="text-align: center;">Command unit/s</td> <td style="text-align: center;">0 to 2147483647 command unit/s</td> </tr> </tbody> </table>			Extend monitor value (Note 2)	Monitor error unit (Note 1)	Range	1 words	1 rpm	0 to 5000 rpm	0.1 rpm	0 to 6,500.0 rpm	2 words	Command unit/s	0 to 2147483647 command unit/s										
				Extend monitor value (Note 2)			Monitor error unit (Note 1)	Range																			
1 words	1 rpm	0 to 5000 rpm																									
	0.1 rpm	0 to 6,500.0 rpm																									
2 words	Command unit/s	0 to 2147483647 command unit/s																									

(Note 1): The actual speed judgement (unit) setting of monitor value error setting is available since FP7 MC Unit Ver.1.20.

(Note 2): The extension to the monitor value of 2 words is available since FP7 MC Unit Ver.1.20. It is set by changing "Extend monitor value" in MC common settings of CMI configuration to "2word".

## Specifications

●: Available, -: Not available

Axis no.	Unit memory no. (Hex)	Name	Default	Description	R	W
1	UM 03260	Home return setting code	H0	<p>Set the pattern of home return.</p> <p>0: DOG method 1 (Based on front end + Z phase)            1: DOG method 2 (Based on front end)            2: DOG method 3 (Based on back end + Z phase)            3: Limit method 1 (Limit signal + Z phase)            4: Limit method 2 (Limit signal)            5: Phase Z method            6: Stop-on-contact method 1            7: Stop-on-contact method 2 (Stop-on-contact + Z phase)            8: Data set            9: DOG method 4 (Based on back end)</p> <p>Any other settings will be errors.</p>	●	●
1	UM 03261	Home return direction	H0	<p>Set the operation direction of home return.</p> <p>0: Elapsed value decreasing direction (Limit - direction)            1: Elapsed value increasing direction (Limit + direction)</p> <p>Any other settings will be errors. -</p>	●	●
1	UM 03262	Home return acceleration time	U100	<p>Set the acceleration/deceleration time when performing the home return.</p>	●	●
1	UM 03263	Home return deceleration time	U100	<p>Range: 0 to 10,000 (ms)</p> <p>Any other settings will be errors.</p>		
1	UM 03264 -UM 03265	Home return target speed	U1000	<p>Set the target speed when performing the home return as integer.</p> <p>Range: 1 to 2,147,483,647</p> <p>Any other settings will be errors.</p> <p>The ranges vary depending on the unit settings as below.</p> <p>pulse: 1 to 2,147,483,647 pps  <math>\mu</math>m: 1 to 2,147,483,647 <math>\mu</math>m/s            inch: 0.001 to 2,147,483.647 inch/s            degree: 0.001 to 2,147,483.647 rev/s</p>	●	●
1	UM 03266 -UM 03267	Home return creep speed	U100	<p>Set the speed to search the home position in the home return operation. Set the value lower than the home return target speed.</p> <p>Range: 1 to 2,147,483,647</p> <p>Any other settings will be errors.</p> <p>The ranges vary depending on the unit settings as below.</p> <p>pulse: 1 to 2,147,483,647 pps  <math>\mu</math>m: 1 to 2,147,483,647 <math>\mu</math>m/s            inch: 0.001 to 2,147,483.647 inch/s            degree: 0.001 to 2,147,483.647 rev/s</p>	●	●
1	UM 03268	Reserved for system	-	-	-	-



## 16.7 Unit Memories (Each Axis Setting Area)

●: Available, -: Not available

Axis no.	Unit memory no. (Hex)	Name	Default	Description	R	W												
1	UM 03269	JOG operation setting code	H0	Sets the mode when performing the JOG operation.	●	●												
				<table border="1" style="width: 100%; border-collapse: collapse;"> <thead> <tr> <th>bit</th> <th>Name</th> <th>Description</th> </tr> </thead> <tbody> <tr> <td>0</td> <td>—</td> <td>—</td> </tr> <tr> <td>1</td> <td>Acceleration/ deceleration pattern setting</td> <td>0: Linear acceleration/deceleration 1: S-shaped acceleration/deceleration</td> </tr> <tr> <td>15-2</td> <td>—</td> <td>—</td> </tr> </tbody> </table>			bit	Name	Description	0	—	—	1	Acceleration/ deceleration pattern setting	0: Linear acceleration/deceleration 1: S-shaped acceleration/deceleration	15-2	—	—
				bit			Name	Description										
				0			—	—										
1	Acceleration/ deceleration pattern setting	0: Linear acceleration/deceleration 1: S-shaped acceleration/deceleration																
15-2	—	—																
1	UM 0326A	JOG operation acceleration time	U100	Sets the acceleration/deceleration time when performing the JOG operation. Range: 0 to 10,000 (ms)	●	●												
1	UM 0326B	JOG operation deceleration time	U100	Any other settings will be errors.														
1	UM 0326C -UM 0326D	JOG operation target speed	U1000	Set the target speed for performing the JOG operation as integer. Range: 1 to 2,147,483,647 Any other settings will be errors. The ranges vary depending on the unit settings as below. pulse: 1 to 2,147,483,647 pps μm: 1 to 2,147,483,647 μm/s inch: 0.001 to 2,147,483.647 inch/s degree: 0.001 to 2,147,483.647 rev/s	●	●												
1	UM 0326E -UM 0326F	Inching movement amount	U1	Set the inching movement amount as integer. The ranges vary depending on the unit settings as below. pulse: 1 to 2,147,483,647 pulses μm (0.1μm): 0.1 to 214,748,364.7 μm μm (1μm): 1 to 2,147,483,647 μm inch (0.00001 inch): 0.00001 to 21,474.83647 inches inch (0.0001 inch): 0.0001 to 214,748.3647 inches degree (0.1 degree): 0.1 to 214,748,364.7 degrees degree (1 degree): 1 to 2,147,483,647 degrees Any other settings will be errors. Also, the inching movement amount does not change when changing the operation speed rate.	●	●												
1	UM 03270 -UM 03272	Reserved for system	-	-	-	-												
1	UM 03273	Emergency stop deceleration time	U100	Set the deceleration time at the time of emergency stop. Range: 0 to 10,000 (ms) Any other settings will be errors.	●	●												
1	UM 03274	Reserved for system	-	-	-	-												
1	UM 03275	Limit stop deceleration time	U100	Set the deceleration time at the time of limit stop. Range: 0 to 10,000 (ms) Any other settings will be errors.	●	●												
1	UM 03276	Reserved for system	-	-	-	-												

# Specifications

●: Available, -: Not available

Axis no.	Unit memory no. (Hex)	Name	Default	Description	R	W												
1	UM 03277	Error stop deceleration time	U100	Set the deceleration time at the time of error stop. Range: 0 to 10,000 (ms) Any other settings will be errors.	●	●												
1	UM 03278 -UM 0327C	Reserved for system	-	-	-	-												
1	UM 0327D	Home return stop-on-contact torque value	U100	Set this item when specifying the home return stop-on-contact method. Range: 0 to 5000 (0.0% to 500.0%)	●	●												
1	UM 0327E	Home return stop-on-contact judgment time	U100	Set this item when specifying the home return stop-on-contact method. Range: 0 to 10,000 (ms)	●	●												
1	UM 0327F -UM 03280	Reserved for system	-	-	-	-												
1	UM 03281	J-point operation setting code	H0	Set the acceleration/deceleration pattern when performing the J-point control <table border="1" style="width: 100%; border-collapse: collapse;"> <thead> <tr> <th>bit</th> <th>Name</th> <th>Description</th> </tr> </thead> <tbody> <tr> <td>0</td> <td>—</td> <td>—</td> </tr> <tr> <td>1</td> <td>Acceleration/ deceleration pattern setting</td> <td>0: Linear acceleration/ deceleration 1: S-shaped acceleration/ deceleration</td> </tr> <tr> <td>15-2</td> <td>—</td> <td>—</td> </tr> </tbody> </table>	bit	Name	Description	0	—	—	1	Acceleration/ deceleration pattern setting	0: Linear acceleration/ deceleration 1: S-shaped acceleration/ deceleration	15-2	—	—	●	●
bit	Name	Description																
0	—	—																
1	Acceleration/ deceleration pattern setting	0: Linear acceleration/ deceleration 1: S-shaped acceleration/ deceleration																
15-2	—	—																
1	UM 03282	J-point control acceleration time	U100	Sets the acceleration/deceleration time when performing the J-point control. Range: 0 to 10,000 (ms) Any other settings will be errors.	●	●												
1	UM 03283	J-point control deceleration time	U100															
1	UM 03284 -UM 03285	J-point control target speed	U1000	Sets the target speed when performing the J-point control as integer. Range: 1 to 2,147,483,647 Any other settings will be errors. The ranges vary depending on the unit settings as below. pulse: 1 to 2,147,483,647 pps μm: 1 to 2,147,483,647 μm/s inch: 0.001 to 2,147,483.647 inch/s degree: 0.001 to 2,147,483.647 rev/s	●	●												
1	UM 03286 -UM 0328D	Reserved for system	-	-	-	-												

## 16.7 Unit Memories (Each Axis Setting Area)

●: Available, -: Not available

Axis no.	Unit memory no. (Hex)	Name	Default	Description	R	W
1	UM 0328E -UM 0328F	Home coordinates	K0	<p>Set the home coordinates to be set after the completion of the home return. Range: -2,147,483,648 to 2,147,483,647</p> <p>The ranges vary depending on the unit settings as below.</p> <p>pulse: -2,147,483,648 to 2,147,483,647 pulses  <math>\mu\text{m}</math> (0.1 <math>\mu\text{m}</math>): -214,748,364.8 to 214,748,364.7 <math>\mu\text{m}</math>  <math>\mu\text{m}</math> (1 <math>\mu\text{m}</math>): -2,147,483,648 to 2,147,483,647 <math>\mu\text{m}</math>                      inch (0.00001 inch) : -21,474.83648 to 21,474.83647 inch                      inch (0.0001 inch) : -214,748.3648 to 214,748.3647 inch                      degree (0.1 degree): -214,748,364.8 to 214,748,364.7 degrees                      degree (1 degree): -2,147,483,648 to 2,147,483,647 degrees</p> <p>Example) When the unit is <math>\mu\text{m}</math> (0.1 <math>\mu\text{m}</math>), set to "10000" for making it be 1000.0 <math>\mu\text{m}</math>.</p>	●	●
1	UM 03290 -UM 032BF	Reserved for system	-	-	-	-

### 16.7.4 Configuration of Positioning Data Setting Area

The positioning data setting area is used for reading or writing positioning data by user programs. It is constituted by 24 buffers (buffer no. 1 to buffer no.24).

UM 00000		Whole unit memory map			
UM 0007F	UM 00080	System area	128 words		
UM 0017F	UM 00180	Input control area	256 words		
UM 0027F	UM 00280	Output control area	256 words		
		Common area	9,104 words		
UM 0260F	UM 02610	System area	48 words		
UM 0263F	UM 02640	Each axis information area	3,072 words		
UM 0323F	UM 03240	Each axis setting area	396,480 words	UM 03240	Parameter setting area 12,288 words
				UM 0623F	UM 06240
UM 63EFF	UM 63F00	System area	64 words		
UM 63F3F	UM 63F40	Synchronous control setting area	10,752 words		
UM 6693F	UM 66940	Positioning operation change setting area	1,536 words		
UM 66F3F	UM 66F40	Cam pattern editing area	106 words		
UM 66FA9					

  

Starting no.	Name	No. of words
UM 06240	Buffer #1 Positioning data setting area	16,008 words
UM 0A0C8	Buffer #2 Positioning data setting area	16,008 words
:		
UM 217F8	Buffer #8 Positioning data setting area	16,008 words
:		
UM 40C38	Buffer #16 Positioning data setting area	16,008 words
:		
UM 60078	Buffer #24 Positioning data setting area	16,008 words

■ Constitution of buffers

Each buffer is constituted by the "control area (8 words)" which specifies an operation to be executed and "positioning data setting area (16,000 words)" which sets positioning data.

The following figure shows the constitution of buffer no. 1. Buffers no. 2 to 24 has the same constitution.

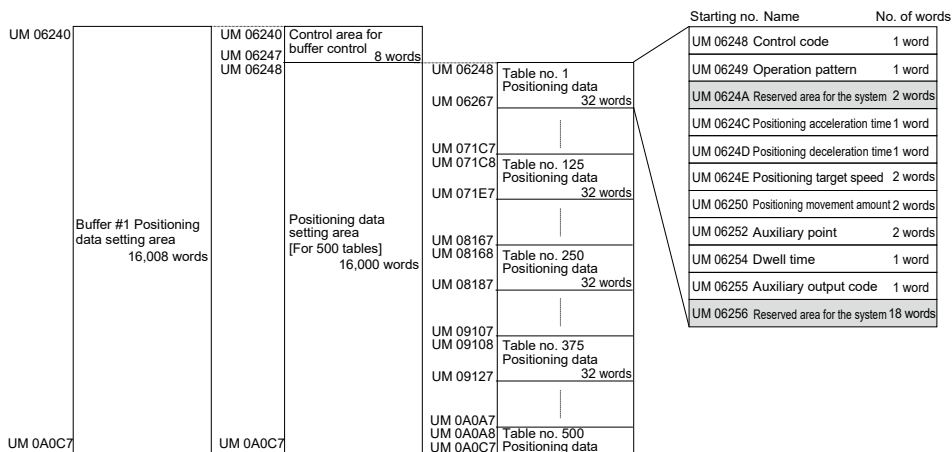

■ Buffers 1 to 8

	Buffer 1	Buffer 2	Buffer 3	Buffer 4	Buffer 5	Buffer 6	Buffer 7	Buffer 8
Request flag control	UM06240	UM0A0C8	UM0DF50	UM11DD8	UM15C60	UM19AE8	UM1D970	UM217F8
Request code control	UM06241	UM0A0C9	UM0DF51	UM11DD9	UM15C61	UM19AE9	UM1D971	UM217F9
Response code control	UM06242	UM0A0CA	UM0DF52	UM11DDA	UM15C62	UM19AEA	UM1D972	UM217FA
Axis number control	UM06243	UM0A0CB	UM0DF53	UM11ddb	UM15C63	UM19AEB	UM1D973	UM217FB
Starting table number	UM06244	UM0A0CC	UM0DF54	UM11DDC	UM15C64	UM19AEC	UM1D974	UM217FC
Table size	UM06245	UM0A0CD	UM0DF55	UM11DDD	UM15C65	UM19AED	UM1D975	UM217FD
Use or non-use of extended tables	UM06246	UM0A0CE	UM0DF56	UM11DDE	UM15C66	UM19AEE	UM1D976	UM217FE
Extended table corresponding axis no.	UM06247	UM0A0CF	UM0DF57	UM11DDF	UM15C67	UM19AEF	UM1D977	UM217FF
Table no. 1	UM06248	UM0A0D0	UM0DF58	UM11DE0	UM15C68	UM19AF0	UM1D978	UM21800
Table no. 2	UM06268	UM0A0F0	UM0DF78	UM11E00	UM15C88	UM19B10	UM1D998	UM21820
Table no. 3	UM06288	UM0A110	UM0DF98	UM11E20	UM15CA8	UM19B30	UM1D9B8	UM21840
-	-	-	-	-	-	-	-	-
Table no. 100	UM06EA8	UM0AD30	UM0EBB8	UM12A40	UM168C8	UM1A750	UM1E5D8	UM22460
-	-	-	-	-	-	-	-	-
Table no. 200	UM07B28	UM0B9B0	UM0F838	UM136C0	UM17548	UM1B3D0	UM1F258	UM230E0
-	-	-	-	-	-	-	-	-
Table no. 300	UM087A8	UM0C630	UM104B8	UM14340	UM181C8	UM1C050	UM1FED8	UM23D60
-	-	-	-	-	-	-	-	-
Table no. 400	UM09428	UM0D2B0	UM11138	UM14FC0	UM18E48	UM1CCD0	UM20B58	UM249E0
-	-	-	-	-	-	-	-	-
Table no. 500	UM0A0A8	UM0DF30	UM11DB8	UM15C40	UM19AC8	UM1D950	UM217D8	UM25660

(Note): The difference between the starting numbers of adjacent tables is H20 (for 32 words).

## Specifications

### ■ Buffers 9 to 16

	Buffer 9	Buffer 10	Buffer 11	Buffer 12	Buffer 13	Buffer 14	Buffer 15	Buffer 16
Request flag control	UM25680	UM29508	UM2D390	UM31218	UM350A0	UM38F28	UM3CDB0	UM40C38
Request code control	UM25681	UM29509	UM2D391	UM31219	UM350A1	UM38F29	UM3CDB1	UM40C39
Response code control	UM25682	UM2950A	UM2D392	UM3121A	UM350A2	UM38F2A	UM3CDB2	UM40C3A
Axis number control	UM25683	UM2950B	UM2D393	UM3121B	UM350A3	UM38F2B	UM3CDB3	UM40C3B
Starting table number	UM25684	UM2950C	UM2D394	UM3121C	UM350A4	UM38F2C	UM3CDB4	UM40C3C
Table size	UM25685	UM2950D	UM2D395	UM3121D	UM350A5	UM38F2D	UM3CDB5	UM40C3D
Use or non-use of extended tables	UM25686	UM2950E	UM2D396	UM3121E	UM350A6	UM38F2E	UM3CDB6	UM40C3E
Extended table corresponding axis no.	UM25687	UM2950F	UM2D397	UM3121F	UM350A7	UM38F2F	UM3CDB7	UM40C3F
Table no. 1	UM25688	UM29510	UM2D398	UM31220	UM350A8	UM38F30	UM3CDB8	UM40C40
Table no. 2	UM256A8	UM29530	UM2D3B8	UM31240	UM350C8	UM38F50	UM3CDD8	UM40C60
Table no. 3	UM256C8	UM29550	UM2D3D8	UM31260	UM350E8	UM38F70	UM3CDF8	UM40C80
-	-	-	-	-	-	-	-	-
Table no. 100	UM262E8	UM2A170	UM2DFF8	UM31E80	UM35D08	UM39B90	UM3DA18	UM418A0
-	-	-	-	-	-	-	-	-
Table no. 200	UM26F68	UM2ADF0	UM2EC78	UM32B00	UM36988	UM3A810	UM3E698	UM42520
-	-	-	-	-	-	-	-	-
Table no. 300	UM27BE8	UM2BA70	UM2F8F8	UM33780	UM37608	UM3B490	UM3F318	UM431A0
-	-	-	-	-	-	-	-	-
Table no. 400	UM28868	UM2C6F0	UM30578	UM34400	UM38288	UM3C110	UM3FF98	UM43E20
-	-	-	-	-	-	-	-	-
Table no. 500	UM294E8	UM2D370	UM311F8	UM35080	UM38F08	UM3CD90	UM 40C18	UM 44AA0

(Note): The difference between the starting numbers of adjacent tables is H20 (for 32 words).

## ■ Buffers 17 to 24

	Buffer 17	Buffer 18	Buffer 19	Buffer 20	Buffer 21	Buffer 22	Buffer 23	Buffer 24
Request flag control	UM44AC0	UM48948	UM4C7D0	UM50658	UM544E0	UM58368	UM5C1F0	UM60078
Request code control	UM44AC1	UM48949	UM4C7D1	UM50659	UM544E1	UM58369	UM5C1F1	UM60079
Response code control	UM44AC2	UM4894A	UM4C7D2	UM5065A	UM544E2	UM5836A	UM5C1F2	UM6007A
Axis number control	UM44AC3	UM4894B	UM4C7D3	UM5065B	UM544E3	UM5836B	UM5C1F3	UM6007B
Starting table number	UM44AC4	UM4894C	UM4C7D4	UM5065C	UM544E4	UM5836C	UM5C1F4	UM6007C
Table size	UM44AC5	UM4894D	UM4C7D5	UM5065D	UM544E5	UM5836D	UM5C1F5	UM6007D
Use or non-use of extended tables	UM44AC6	UM4894E	UM4C7D6	UM5065E	UM544E6	UM5836E	UM5C1F6	UM6007E
Extended table corresponding axis no.	UM44AC7	UM4894F	UM4C7D7	UM5065F	UM544E7	UM5836F	UM5C1F7	UM6007F
Table no. 1	UM44AC8	UM48950	UM4C7D8	UM50660	UM544E8	UM58370	UM5C1F8	UM60080
Table no. 2	UM44AE8	UM48970	UM4C7F8	UM50680	UM54508	UM58390	UM5C218	UM600A0
Table no. 3	UM44B08	UM48990	UM4C818	UM506A0	UM54528	UM583B0	UM5C238	UM600C0
-	-	-	-	-	-	-	-	-
Table no. 100	UM45728	UM495B0	UM4D438	UM512C0	UM55148	UM58FD0	UM5CE58	UM60CE0
-	-	-	-	-	-	-	-	-
Table no. 200	UM463A8	UM4A230	UM4E0B8	UM51F40	UM55DC8	UM59C50	UM5DAD8	UM61960
-	-	-	-	-	-	-	-	-
Table no. 300	UM47028	UM4AEB0	UM4ED38	UM52BC0	UM56A48	UM5A8D0	UM5E758	UM625E0
-	-	-	-	-	-	-	-	-
Table no. 400	UM47CA8	UM4BB30	UM4F9B8	UM53840	UM576C8	UM5B550	UM5F3D8	UM63260
-	-	-	-	-	-	-	-	-
Table no. 500	UM48928	UM4C7B0	UM50638	UM544C0	UM58348	UM5C1D0	UM60058	UM63EE0

(Note): The difference between the starting numbers of adjacent tables is H20 (for 32 words).

**16.7.4.1 Control Area for Buffer Control**

This area is used for reading or writing positioning data by user programs.

●: Available, -: Not available

Buffer no.	Unit memory no. (Hex)	Name	Default	Description	R	W						
1	UM 06240	Request flag control	H0	Write data to this area for sending/receiving data of buffers for positioning data. After the completion of the execution, it is rewritten to H0 by FP7 MC Unit. H0000: No request H0001: Request Any other settings will be errors.	●	●						
1	UM 06241	Request code control	H0	Set the request code of data control of buffer for positioning data. H0080: Read request H0081: Write request Any other settings will be errors.	●	●						
1	UM 06242	Response code control	H0	Stores the response code for the request of the buffer for positioning data. H0000: Complete H0001: In progress HFF00: Setting value error	●	-						
1	UM 06243	Axis number control	U1	Specify the axis number of positioning data to be transferred. <table border="1" style="width: 100%; border-collapse: collapse;"> <thead> <tr> <th style="width: 20%;">Range</th> <th>Corresponding axis no.</th> </tr> </thead> <tbody> <tr> <td>1-64</td> <td>Corresponds to the existing axes 1 to 64.</td> </tr> <tr> <td>65-96</td> <td>Corresponds to the virtual axes 1 to 32.</td> </tr> </tbody> </table> Any other settings will be errors.	Range	Corresponding axis no.	1-64	Corresponds to the existing axes 1 to 64.	65-96	Corresponds to the virtual axes 1 to 32.	●	●
Range	Corresponding axis no.											
1-64	Corresponds to the existing axes 1 to 64.											
65-96	Corresponds to the virtual axes 1 to 32.											
1	UM 06244	Starting table number	U1	Specify the starting table number of positioning data to be transferred. Range: 1 to 1000 Any other settings will be errors.	●	●						
1	UM 06245	Table size	U1	Specify the table size of positioning data to be transferred. Range: 1 to 500 Any other settings will be errors.	●	●						



## 16.7 Unit Memories (Each Axis Setting Area)

●: Available, -: Not available

Buffer no.	Unit memory no. (Hex)	Name	Default	Description	R	W						
1	UM 06246	Extended positioning table usage setting	H0	Set whether to use the extended positioning table or not. <table border="1" style="width: 100%; border-collapse: collapse;"> <thead> <tr> <th style="text-align: center;">bit</th> <th style="text-align: center;">Name</th> <th style="text-align: center;">Description</th> </tr> </thead> <tbody> <tr> <td style="text-align: center;">15-0</td> <td style="text-align: center;">Extended positioning table usage setting</td> <td>               0: Not make the table setting                1: Make the table setting                Any other settings will be errors.             </td> </tr> </tbody> </table> <p>* When using the extended positioning table; table nos. 401 to 500 is used as extended table nos. 10,001 to 10,100.</p>	bit	Name	Description	15-0	Extended positioning table usage setting	0: Not make the table setting 1: Make the table setting Any other settings will be errors.	●	●
bit	Name	Description										
15-0	Extended positioning table usage setting	0: Not make the table setting 1: Make the table setting Any other settings will be errors.										
1	UM 06247	Extended positioning table usage setting corresponding axis no.	U0	Set transfer axis numbers of positioning data. <table border="1" style="width: 100%; border-collapse: collapse;"> <thead> <tr> <th style="text-align: center;">Range</th> <th style="text-align: center;">Corresponding axis no.</th> </tr> </thead> <tbody> <tr> <td style="text-align: center;">1 to 64</td> <td style="text-align: center;">Corresponds to the existing axes 1 to 64.</td> </tr> <tr> <td style="text-align: center;">65 to 96</td> <td style="text-align: center;">Corresponds to the virtual axes 1 to 32.</td> </tr> </tbody> </table> <p>Any other settings will be errors.</p>	Range	Corresponding axis no.	1 to 64	Corresponds to the existing axes 1 to 64.	65 to 96	Corresponds to the virtual axes 1 to 32.	●	●
Range	Corresponding axis no.											
1 to 64	Corresponds to the existing axes 1 to 64.											
65 to 96	Corresponds to the virtual axes 1 to 32.											

16.7.4.2 Positioning Data Setting Area

The positioning data setting area is used for reading or writing positioning data by user programs. The following table shows the offset addresses from the starting table of each buffer.

●: Available, -: Not available

Offset address	Name	Default	Description	R	W												
000H	Control code	H0	Set the position setting mode and acceleration/deceleration pattern for the positioning operation.	●	●												
			<table border="1"> <thead> <tr> <th>bit</th> <th>Name</th> <th>Description</th> </tr> </thead> <tbody> <tr> <td>0</td> <td>Control method</td> <td>0: Increment mode 1: Absolute mode</td> </tr> <tr> <td>1</td> <td>Acceleration/ deceleration type</td> <td>0: Linear acceleration/deceleration 1: S-shaped acceleration/deceleration</td> </tr> <tr> <td>15-2</td> <td>—</td> <td>—</td> </tr> </tbody> </table>			bit	Name	Description	0	Control method	0: Increment mode 1: Absolute mode	1	Acceleration/ deceleration type	0: Linear acceleration/deceleration 1: S-shaped acceleration/deceleration	15-2	—	—
			bit			Name	Description										
			0			Control method	0: Increment mode 1: Absolute mode										
1	Acceleration/ deceleration type	0: Linear acceleration/deceleration 1: S-shaped acceleration/deceleration															
15-2	—	—															
001H	Operation pattern	H0	Set the single and interpolation operation pattern for the positioning operation. The relation of the interpolation depends on the settings in the axis group setting area in the common area of the unit memory. In the interpolation operation, the setting for the axis with the smallest number in an axis group is effective.	●	●												
			<table border="1"> <thead> <tr> <th>bit</th> <th>Name</th> <th>Description</th> </tr> </thead> <tbody> <tr> <td>7-0</td> <td>Control pattern</td> <td>H00: E-point control (End point control) H01: P-point control (Pass point control) H02: C-point control (Continuance point control) H03: J-point control (Speed point control) Any other settings will be errors.</td> </tr> <tr> <td>15-8</td> <td>Interpolation setting</td> <td>H 00: Linear interpolation (Composite speed) H 01: Linear interpolation (Major axis speed) H 10: Circular interpolation (Center point/CW direction) H 11: Circular interpolation (Center point/CCW direction) H 20: Circular interpolation (Pass point): H 50: Spiral interpolation (Center point/CW direction/1st axis feed) H 51: Spiral interpolation (Center point/CCW direction/1st axis feed) H 52: Spiral interpolation (Center point/CW direction/2nd axis feed) H 53: Spiral interpolation (Center point/CCW direction/2nd axis feed) H 54: Spiral interpolation (Center point/CW direction/3rd axis feed) H 55: Spiral interpolation (Center point/CCW direction/3rd axis feed) H 60: Spiral interpolation (Pass point/1st axis feed) H 61: Spiral interpolation (Pass point/2nd axis feed) H 62: Spiral interpolation (Pass point/3rd axis feed) Any other settings will be errors.</td> </tr> </tbody> </table>			bit	Name	Description	7-0	Control pattern	H00: E-point control (End point control) H01: P-point control (Pass point control) H02: C-point control (Continuance point control) H03: J-point control (Speed point control) Any other settings will be errors.	15-8	Interpolation setting	H 00: Linear interpolation (Composite speed) H 01: Linear interpolation (Major axis speed) H 10: Circular interpolation (Center point/CW direction) H 11: Circular interpolation (Center point/CCW direction) H 20: Circular interpolation (Pass point): H 50: Spiral interpolation (Center point/CW direction/1st axis feed) H 51: Spiral interpolation (Center point/CCW direction/1st axis feed) H 52: Spiral interpolation (Center point/CW direction/2nd axis feed) H 53: Spiral interpolation (Center point/CCW direction/2nd axis feed) H 54: Spiral interpolation (Center point/CW direction/3rd axis feed) H 55: Spiral interpolation (Center point/CCW direction/3rd axis feed) H 60: Spiral interpolation (Pass point/1st axis feed) H 61: Spiral interpolation (Pass point/2nd axis feed) H 62: Spiral interpolation (Pass point/3rd axis feed) Any other settings will be errors.			
bit	Name	Description															
7-0	Control pattern	H00: E-point control (End point control) H01: P-point control (Pass point control) H02: C-point control (Continuance point control) H03: J-point control (Speed point control) Any other settings will be errors.															
15-8	Interpolation setting	H 00: Linear interpolation (Composite speed) H 01: Linear interpolation (Major axis speed) H 10: Circular interpolation (Center point/CW direction) H 11: Circular interpolation (Center point/CCW direction) H 20: Circular interpolation (Pass point): H 50: Spiral interpolation (Center point/CW direction/1st axis feed) H 51: Spiral interpolation (Center point/CCW direction/1st axis feed) H 52: Spiral interpolation (Center point/CW direction/2nd axis feed) H 53: Spiral interpolation (Center point/CCW direction/2nd axis feed) H 54: Spiral interpolation (Center point/CW direction/3rd axis feed) H 55: Spiral interpolation (Center point/CCW direction/3rd axis feed) H 60: Spiral interpolation (Pass point/1st axis feed) H 61: Spiral interpolation (Pass point/2nd axis feed) H 62: Spiral interpolation (Pass point/3rd axis feed) Any other settings will be errors.															
002H -003H	Reserved for system	-	-	-	-												
004H	Positioning acceleration time	U100	Set the acceleration and deceleration time for the positioning operation. Range: 0 to 10,000 [ms]	●	●												
005H	Positioning deceleration time	U100	Any other settings will be errors. In the interpolation control, the setting for the axis with the smallest number in an axis group is effective.	●	●												

## 16.7 Unit Memories (Each Axis Setting Area)

●: Available, -: Not available

Offset address	Name	Default	Description	R	W
006H -007H	Positioning target speed (Interpolation speed)	U1000	<p>For a single axis operation, it is the target speed of the corresponding axis. For an interpolation operation, it is the target speed of the interpolation. In the interpolation operation, the setting for the axis with the smallest number in an axis group is effective.</p> <p>Range: 1 to 2,147,483,647</p> <p>Any other settings will be errors.</p> <p>The ranges vary depending on the unit settings as below.</p> <p>pulse: 1 to 2,147,483,647 pps  <math>\mu\text{m}</math>: 1 to 2,147,483,647 <math>\mu\text{m/s}</math>                      inch: 0.001 to 2,147,483.647 inch/s                      degree: 0.001 to 2,147,483.647 rev/s</p>	●	●
008H -009H	Positioning movement amount	K0	<p>Set the position command value for the positioning operation. It is the movement amount in the case of increment, and coordinates in the case of absolute depending on the control code setting.</p> <p>Range: -2,147,483,648 to +2,147,483,647</p> <p>Any other settings will be errors.</p> <p>The ranges vary depending on the unit settings as below.</p> <p>pulse: -2,147,483,648 to 2,147,483,647 pulse  <math>\mu\text{m}</math> (0.1<math>\mu\text{m}</math>): -214,748,364.8 to 214,748,364.7 <math>\mu\text{m}</math>  <math>\mu\text{m}</math> (1<math>\mu\text{m}</math>): -2,147,483,648 to 2,147,483,647 <math>\mu\text{m}</math>                      inch (0.00001 inch): -21,474.83648 to 21,474.83647 inches                      inch (0.0001 inch): -214,748.3648 to 214,748.3647 inches                      degree (0.1 degree): -214,748,364.8 to 214,748,364.7 degrees                      degree (1 degree): -2,147,483,648 to 2,147,483,647 degrees</p>	●	●
00AH -00BH	Auxiliary point	K0	<p>Set the auxiliary point (coordinate of center or pass point) in the case of circular interpolation or spiral interpolation control.</p> <p>Range: -2,147,483,648 to +2,147,483,647</p> <p>Any other settings will be errors.</p> <p>The ranges vary depending on the unit settings as below.</p> <p>pulse: -2,147,483,648 to 2,147,483,647 pulse  <math>\mu\text{m}</math> (0.1<math>\mu\text{m}</math>): -214,748,364.8 to 214,748,364.7 <math>\mu\text{m}</math>  <math>\mu\text{m}</math> (1<math>\mu\text{m}</math>): -2,147,483,648 to 2,147,483,647 <math>\mu\text{m}</math>                      inch (0.00001 inch): -21,474.83648 to 21,474.83647 inches                      inch (0.0001 inch): -214,748.3648 to 214,748.3647 inches                      degree (0.1 degree): -214,748,364.8 to 214,748,364.7 degrees                      degree (1 degree): -2,147,483,648 to 2,147,483,647 degrees</p>	●	●

## Specifications

●: Available, -: Not available

Offset address	Name	Default	Description	R	W
00CH	Dwell time	U0	<p>When the positioning operation of this table is finished;</p> <p>C-point (Continuance point)      The motor stops for the dwell time and the next operation is started.</p> <p>P-point (Pass point)                It is ignored.</p> <p>J-point (Speed control)            It is ignored.</p> <p>E-point (End point)                The positioning done contact turns on after waiting for the dwell time.</p> <p>Range: 0 to 32,767 (ms)</p> <p>Any other settings will be errors.</p>	●	●
00DH	Auxiliary output code	U0	Set arbitrary data as auxiliary output codes when using the auxiliary output function.	●	●
00EH -01FH	Reserved for system	—	—	-	-

## 16.8 Unit Memories (Synchronous Control Setting Area)

### 16.8.1 Configuration of Synchronous Control Setting Area

Whole unit memory map	
UM 00000	System area
UM 0007F	128 words
UM 00080	Input control area
UM 0017F	256 words
UM 00180	Output control area
UM 0027F	256 words
UM 00280	
	Common area
	9,104 words
UM 0260F	
UM 02610	System area
	48 words
UM 0263F	
UM 02640	Each axis
	information area
	3,072 words
UM 0323F	
UM 03240	
	Each axis setting area
	396,480 words
UM 63EFF	
UM 63F00	System area
UM 63F3F	64 words
UM 63F40	Synchronous
	control setting area
	10,752 words
UM 6693F	
UM 66940	Positioning operation
	change setting area
	1,536 words
UM 66F3F	
UM 66F40	Cam pattern editing
	area
UM 66FA9	106 words

Starting no.	Name	No. of words
UM 63F40	Synchronous control setting area of 1st axis	112 words
UM 63FAF	Synchronous control setting area of 2nd axis	112 words
UM 63FB0	:	
UM 645CF	:	
UM 645D0	Synchronous control setting area of 16th axis	112 words
	:	
UM 64CCF	:	
UM 64CD0	Synchronous control setting area of 32nd axis	112 words
	:	
UM 653CF	:	
UM 653D0	Synchronous control setting area of 48th axis	112 words
	:	
UM 65ACF	Synchronous control setting area of 64th axis	112 words
UM 65AD0	Synchronous control setting area of virtual 1st axis	112 words
UM 65B3F	Synchronous control setting area of virtual 1st axis	112 words
UM 65B40	Synchronous control setting area of virtual 1st axis	112 words
UM 661CF		
UM 661D0	Synchronous control setting area of virtual 16th axis	112 words
UM 658CF		
UM 668D0	Synchronous control setting area of virtual 32nd axis	112 words
UM 6693F		

Starting no.	Name	No. of words
UM 63F40	Synchronous control common setting area	16 words
UM 63F50	Electronic gear setting area	16 words
UM 63F60	Clutch setting area	48 words
UM 63F90	Electronic cam setting area	32 words

16.8.2 Synchronous Control Setting Area

●: Available, -: Not available

Axis no.	Unit memory no. (Hex)	Name	Default	Description	R	W																																							
1	UM 63F40	Synchronous master axis selection	H0	<p>Set the synchronous master axis for each axis.</p> <table border="1"> <thead> <tr> <th>Value</th> <th colspan="2">Setting</th> </tr> </thead> <tbody> <tr> <td>H 0000</td> <td>U0</td> <td>The target axis is the master axis.</td> </tr> <tr> <td>H 0001</td> <td>U1</td> <td>Axis 1</td> </tr> <tr> <td>H 0002</td> <td>U2</td> <td>Axis 2</td> </tr> <tr> <td>-----</td> <td>-----</td> <td>-----</td> </tr> <tr> <td>H 0010</td> <td>U16</td> <td>Axis 16</td> </tr> <tr> <td>-----</td> <td>-----</td> <td>-----</td> </tr> <tr> <td>H 0020</td> <td>U32</td> <td>Axis 32</td> </tr> <tr> <td>-----</td> <td>-----</td> <td>-----</td> </tr> <tr> <td>H 0040</td> <td>U64</td> <td>Axis 64</td> </tr> <tr> <td>H 0041</td> <td>U65</td> <td>Virtual axis 1</td> </tr> <tr> <td>-----</td> <td>-----</td> <td>-----</td> </tr> <tr> <td>H 0060</td> <td>U96</td> <td>Virtual axis 32</td> </tr> </tbody> </table> <p>Any other settings will be errors.</p>	Value	Setting		H 0000	U0	The target axis is the master axis.	H 0001	U1	Axis 1	H 0002	U2	Axis 2	-----	-----	-----	H 0010	U16	Axis 16	-----	-----	-----	H 0020	U32	Axis 32	-----	-----	-----	H 0040	U64	Axis 64	H 0041	U65	Virtual axis 1	-----	-----	-----	H 0060	U96	Virtual axis 32	●	●
Value	Setting																																												
H 0000	U0	The target axis is the master axis.																																											
H 0001	U1	Axis 1																																											
H 0002	U2	Axis 2																																											
-----	-----	-----																																											
H 0010	U16	Axis 16																																											
-----	-----	-----																																											
H 0020	U32	Axis 32																																											
-----	-----	-----																																											
H 0040	U64	Axis 64																																											
H 0041	U65	Virtual axis 1																																											
-----	-----	-----																																											
H 0060	U96	Virtual axis 32																																											
1	UM 63F41	Synchronous output function selection	H0	<p>Set the synchronous function for each axis.</p> <table border="1"> <thead> <tr> <th>bit</th> <th>Name</th> <th>Description</th> </tr> </thead> <tbody> <tr> <td>0</td> <td>Electronic gear operation setting</td> <td rowspan="4">0: Not use 1: Use</td> </tr> <tr> <td>1</td> <td>Clutch operation setting</td> </tr> <tr> <td>2</td> <td>Electronic operation setting</td> </tr> <tr> <td>3</td> <td>Advance angle correction operation setting</td> </tr> <tr> <td>15-4</td> <td>Reserved for system</td> <td>—</td> </tr> </tbody> </table>	bit	Name	Description	0	Electronic gear operation setting	0: Not use 1: Use	1	Clutch operation setting	2	Electronic operation setting	3	Advance angle correction operation setting	15-4	Reserved for system	—	●	●																								
bit	Name	Description																																											
0	Electronic gear operation setting	0: Not use 1: Use																																											
1	Clutch operation setting																																												
2	Electronic operation setting																																												
3	Advance angle correction operation setting																																												
15-4	Reserved for system	—																																											
1	UM 63F42	Synchronous slave single deceleration stop deceleration method	H0	<table border="1"> <thead> <tr> <th>bit</th> <th>Name</th> <th>Description</th> </tr> </thead> <tbody> <tr> <td>0</td> <td>Not used</td> <td></td> </tr> <tr> <td>1</td> <td>Synchronous slave single Deceleration stop deceleration method</td> <td>0: Linear deceleration 1: S-shaped deceleration</td> </tr> <tr> <td>15-2</td> <td>Reserved for system</td> <td>—</td> </tr> </tbody> </table>	bit	Name	Description	0	Not used		1	Synchronous slave single Deceleration stop deceleration method	0: Linear deceleration 1: S-shaped deceleration	15-2	Reserved for system	—	●	●																											
bit	Name	Description																																											
0	Not used																																												
1	Synchronous slave single Deceleration stop deceleration method	0: Linear deceleration 1: S-shaped deceleration																																											
15-2	Reserved for system	—																																											
1	UM 63F43	Synchronous slave single deceleration stop deceleration time	U100	<p>Set the deceleration time when performing the deceleration stop during the synchronous operation.</p> <p>Range: 0 to 10,000 (ms)</p> <p>Any other settings will be errors.</p>	●	●																																							
1	UM 63F44 -UM 63F4F	Reserved for system	-	-	-	-																																							

(Note): The above table shows the unit memory numbers of axis number 1. For details of the whole configuration, refer to "16.8.1 Configuration of Synchronous Control Setting Area".

## 16.8.3 Electronic Gear Setting Area

●: Available, -: Not available

Axis no.	Unit memory no. (Hex)	Name	Default	Description	R	W
1	UM 63F50 -UM 63F51	Gear ratio numerator of each axis	U1	Set the numerator and denominator for the gear ratio of electronic gear separately. Range: U1 to U2147483647	●	●
1	UM 63F52 -UM 63F53	Gear ratio denominator of each axis	U1	Electronic gear ratio is determined by the following formula. Output speed of electronic gear = Operating speed of master axis x (Gear ratio numerator/Gear ratio denominator)	●	●
1	UM 63F54	Gear ratio change time of each axis	U1	Set the time required to change the current gear ratio to a new gear ratio when the new gear ratio is set for the electronic gear in operation. 1 to 10000 [ms]	●	●
1	UM 63F55 -UM 63F5F	Reserved for system	-	-	-	-

(Note): The above table shows the unit memory numbers of axis number 1. For details of the whole configuration, refer to "16.8.1 Configuration of Synchronous Control Setting Area".

16.8.4 Clutch Setting Area

●: Available, -: Not available

Axis no.	Unit memory no. (Hex)	Name	Default	Description	R	W																
1	UM 63F60	Clutch ON trigger type	H0	H0: I/O clutch ON request	●	●																
1	UM 63F61	Clutch ON edge selection	H0	Set the valid condition of trigger signals. H0: Level H1: Leading edge H2: Trailing edge	●	●																
1	UM 63F62 -UM 63F67	Reserved for system	-	-	-	-																
1	UM 63F68	Clutch OFF trigger type	H0	Set the trigger type to detect the clutch OFF state. However, when selecting "Level" for the clutch ON edge selection, the setting of this area is invalid. <table border="1" style="width: 100%; border-collapse: collapse;"> <thead> <tr> <th>bit</th> <th>Name</th> <th>Description</th> </tr> </thead> <tbody> <tr> <td>0</td> <td rowspan="8">Clutch OFF trigger type</td> <td rowspan="8">00H: I/o slave axis clutch OFF request 11H: I/O + Phase after clutch control clutch OFF When setting any other values, an error occurs.</td> </tr> <tr> <td>1</td> </tr> <tr> <td>2</td> </tr> <tr> <td>3</td> </tr> <tr> <td>4</td> </tr> <tr> <td>5</td> </tr> <tr> <td>6</td> </tr> <tr> <td>7</td> </tr> <tr> <td>15-8</td> <td>Reserved for system</td> <td>-</td> </tr> </tbody> </table>	bit	Name	Description	0	Clutch OFF trigger type	00H: I/o slave axis clutch OFF request 11H: I/O + Phase after clutch control clutch OFF When setting any other values, an error occurs.	1	2	3	4	5	6	7	15-8	Reserved for system	-	●	●
bit	Name	Description																				
0	Clutch OFF trigger type	00H: I/o slave axis clutch OFF request 11H: I/O + Phase after clutch control clutch OFF When setting any other values, an error occurs.																				
1																						
2																						
3																						
4																						
5																						
6																						
7																						
15-8	Reserved for system	-																				
1	UM 63F69	Clutch OFF edge selection	H0	Set the valid condition of trigger signals. This item is unavailable when the clutch ON edge selection is set to "H0: Level". H0: Disabled H1: Leading edge H2: Trailing edge	●	●																
1	UM 63F6A	Clutch OFF phase ratio	U0	Set the ratio for the phase at which the clutch turns off when selecting "I/O + Phase after clutch control" for the clutch off trigger type. Range: 0 to 99 (%) Any other settings will be errors.	●	●																
1	UM 63F6B -UM 63F6F	Reserved for system	-	-	-	-																

(Note): The above table shows the unit memory numbers of axis number 1. For details of the whole configuration, refer to "16.8.1 Configuration of Synchronous Control Setting Area".



## 16.8 Unit Memories (Synchronous Control Setting Area)

●: Available, -: Not available

Axis no.	Unit memory no. (Hex)	Name	Default	Description	R	W
1	UM 63F70	Clutch ON method	H0	Select the clutch ON method. H0: Direct H1: Slip	●	●
1	UM 63F71	Reserved for system	-	-	-	-
1	UM 63F72	Clutch ON slip method	H0	H0: Slip time setting	●	●
1	UM 63F73	Clutch ON slip time	U1	Set a slip time when the clutch ON method is set to "H1: Slip". 1 to 10,000 [ms]	●	●
1	UM 63F74 -UM 63F75	Reserved for system	-	-	-	-
1	UM 63F76	Clutch ON slip curve selection	H0	H0: Linear	●	●
1	UM 63F77 -UM 63F7F	Reserved for system	-	-	-	-
1	UM 63F80	Clutch OFF method	H0	Select the clutch OFF method. H0: Direct H1: Slip	●	●
1	UM 63F81	Reserved for system	-	-	-	-
1	UM 63F82	Clutch OFF slip method	H0	H0: Slip time setting	●	●
1	UM 63F83	Clutch OFF slip time	U1	Set a slip time when the clutch OFF method is set to "H1: Slip". 1 to 10,000 [ms]	●	●
1	UM 63F84 -UM 63F85	Reserved for system	-	-	-	-
1	UM 63F86	Clutch OFF slip curve selection	H0	H0: Linear	●	●
1	UM 63F87 -UM 63F8F	Reserved for system	-	-	-	-

(Note): The above table shows the unit memory numbers of axis number 1. For details of the whole configuration, refer to "16.8.1 Configuration of Synchronous Control Setting Area".

16.8.5 Electronic Cam Setting Area

●: Available, -: Not available

Axis no.	Unit memory no. (Hex)	Name	Default	Description	R	W
1	UM 63F90 -UM 63F91	Cam control synchronous master axis cycle	U1	Set the cam control synchronous master cycle. U1 to U2147483647	●	●
1	UM 63F92	Reserved for system	-	-	-	-
1	UM 63F93	Cam pattern number	U1	Set the registered cam pattern number to be used. 1 to 256	●	●
1	UM 63F94 -UM 63F95	Cam stroke amount	U1	Displacement amount upper limit setting for cam control U1 to U2147483647	●	●
1	UM 63F96 -UM 63F97	Advance angle correction reference amount	K0	Set the correction reference amount for calculating the advance angle correction amount when using the advance angle correction function. Range: -2,147,483,648 to 2,147,483,647 The ranges vary depending on the unit settings as below. pulse: -2,147,483,648 to 2,147,483,647 pulses μm (0.1 μm): -214,748,364.8 to 214,748,364.7 μm μm (1 μm): -2,147,483,648 to 2,147,483,647 μm inch (0.00001 inch): -21,474.83648 to 21,474.83647 inches inch (0.0001 inch): -214,748.3648 to 214,748.3647 inches degree (0.1 degree): -214,748,364.8 to 214,748,364.7 degrees degree (1 degree): -2,147,483,648 to 2,147,483,647 degrees Any other settings will be errors.	●	●
1	UM 63F98 -UM 63F99	Advance angle correction reference speed	U100	Set the reference speed for calculating the advance angle correction amount when using the advance angle correction function. Range: 1 to 2,147,483,647 Any other settings will be errors. The ranges vary depending on the unit settings as below. pulse: 1 to 2,147,483,647 pps μm: 1 to 2,147,483,647 μm/s inch: 0.001 to 2,147,483.647 inch/s degree: 0.001 to 2,147,483.647 rev/s	●	●

(Note): The above table shows the unit memory numbers of axis number 1. For details of the whole configuration, refer to "16.8.1 Configuration of Synchronous Control Setting Area".

## 16.8 Unit Memories (Synchronous Control Setting Area)

●: Available, -: Not available

Axis no.	Unit memory no. (Hex)	Name	Default	Description	R	W
1	UM 63F9A	Advance angle correction parameter change time	U100	Set the time required until a changed value is reflected when the parameter related to advance angle correction (advance angle correction reference speed or advance angle correction reference amount) is changed during the electronic cam operation. Range: 0 to 10,000 (ms) Any other settings will be errors.	●	●
1	UM 63F9B -UM 63FAF	Reserved for system	-	-	-	-

(Note): The above table shows the unit memory numbers of axis number 1. For details of the whole configuration, refer to "16.8.1 Configuration of Synchronous Control Setting Area".

## 16.9 Unit Memories (Positioning Operation Change Setting Area)

### 16.9.1 Configuration of Positioning Operation Change Setting Area

Whole unit memory map	
UM 00000	System area 128 words
UM 0007F UM 00080	Input control area 256 words
UM 0017F UM 00180	Output control area 256 words
UM 0027F UM 00280	Common area 9,104 words
UM 0260F UM 02610	System area 48 words
UM 0263F UM 02640	Each axis information area 3,072 words
UM 0323F UM 03240	Each axis setting area 396,480 words
UM 63EFF UM 63F00	System area 64 words
UM 63F3F UM 63F40	Synchronous control setting area 10,752 words
UM 6693F UM 66940	Positioning operation change setting area 1,536 words
UM 66E3F UM 66F40	Cam pattern editing area 106 words
UM 66FA9	

Starting no.	Name	No. of words
UM 66940	Reserved area for the system	6 words
UM 66941	Change mode selection	32 words
UM 66942	Change speed	32 words
UM 66944	Reserved area for the system	32 words
UM 6694A	Change movement amount	32 words

16.9.2 Positioning Speed/Movement Amount Change Parameter

●: Available, -: Not available

Axis no.	Unit memory no. (Hex)	Name	Default	Description	R	W
1	UM 66940	Reserved for system	-	-	-	-
1	UM 66941	Positioning speed change function change mode selection	H0	Area for setting the range of the positioning speed change. 00H: Active table only 01H: Active table to E-point (until the completion of the operation) When setting any other values, the unit operates as the setting of 00H (Active table only).	●	●
1	UM 66942 -UM 66943	Positioning speed change function speed value	U100	Area for setting a change speed for changing the positioning speed. Range: 1 to 2,147,483,647 Any other settings will be errors. The ranges vary depending on the unit settings as below. pulse: 1 to 2,147,483,647 pps µm: 1 to 2,147,483,647 µm/s inch: 0.001 to 2,147,483.647 inch/s degree: 0.001 to 2,147,483.647 rev/s	●	●
-	UM 66944 -UM 66949	Reserved for system	-	-	-	-
1	UM 6694A -UM 6694B	Positioning movement amount change function movement amount	K0	Area for setting a change movement amount for changing the positioning movement amount. Range: -1,073,741,823 to 1,073,741,823 (command unit system)	●	●

## 16.10 Unit Memories (Cam Pattern Editing Area)

### 16.10.1 Configuration of Cam Pattern Editing Area

Whole unit memory map	
UM 00000	System area 128 words
UM 0007F UM 00080	Input control area 256 words
UM 0017F UM 00180	Output control area 256 words
UM 0027F UM 00280	Common area 9,104 words
UM 0260F UM 02610	System area 48 words
UM 0263F UM 02640	Each axis information area 3,072 words
UM 0323F UM 03240	Each axis setting area 396,480 words
UM 63EFF UM 63F00	System area 64 words
UM 63F3F UM 63F40	Synchronous control setting area 10,752 words
UM 6693F UM 66940	Positioning operation change setting area 1,536 words
UM 66F3F UM 66F40	Cam pattern editing area
UM 66FA9	106 words

UM 66F40	Cam pattern no.	6 words
UM 66F41	Reserved area for the system	4 words
UM 66F42	No. of cam pattern setting sections	4 words
UM 66F43	Shift amount	2 words
UM 66F44	Start phase of section 1	6 words
UM 66F45	Displacement of section 1	6 words
UM 66F46	Cam curve of section 1	6 words
UM 66F47	Reserved area for the system	4 words
:		
UM 66F90	Start phase of section 1	6 words
UM 66F91	Displacement of section 1	8 words
UM 66F92	Cam curve of section 1	6 words
UM 66F93	Reserved area for the system	6 words
UM 66F98	Cam pattern reading result	4 words
UM 66F99	Cam pattern rewriting result	2 words
UM 66F9A	Cam pattern update flag	2 words

16.10.2 Cam Pattern Setting Area

●: Available, -: Not available

Axis no.	Unit memory no. (Hex)	Name	Default	Description	R	W																					
-	UM 66F40	Cam pattern no.	U0	<p>When reading: Set a cam pattern number to be read out. When rewriting: Set a cam pattern number to be written.</p> <table border="1"> <thead> <tr> <th rowspan="2">bit</th> <th rowspan="2">Pattern resolution</th> <th colspan="3">Description</th> </tr> <tr> <th>Axis 16</th> <th>Axis 32</th> <th>Axis 64</th> </tr> </thead> <tbody> <tr> <td rowspan="3">15-0</td> <td>1024,2048,4096,8192</td> <td>1 to 64</td> <td>1 to 128</td> <td>1 to 256</td> </tr> <tr> <td>16384</td> <td>1 to 32</td> <td>1 to 64</td> <td>1 to 128</td> </tr> <tr> <td>32768</td> <td>1 to 16</td> <td>1 to 32</td> <td>1 to 64</td> </tr> </tbody> </table> <p>Any other settings will be errors.</p>	bit	Pattern resolution	Description			Axis 16	Axis 32	Axis 64	15-0	1024,2048,4096,8192	1 to 64	1 to 128	1 to 256	16384	1 to 32	1 to 64	1 to 128	32768	1 to 16	1 to 32	1 to 64	●	●
bit	Pattern resolution	Description																									
		Axis 16	Axis 32	Axis 64																							
15-0	1024,2048,4096,8192	1 to 64	1 to 128	1 to 256																							
	16384	1 to 32	1 to 64	1 to 128																							
	32768	1 to 16	1 to 32	1 to 64																							
-	UM 66F41	Reserved for system	-	-	-	-																					
-	UM 66F42	No. of cam pattern setting sections	U0	<p>When reading, stores the number of setting sections of the read cam pattern table. When rewriting, the cam curve number of the rewritten cam pattern table is set.</p> <table border="1"> <thead> <tr> <th>bit</th> <th>Name</th> <th>Description</th> </tr> </thead> <tbody> <tr> <td>15-0</td> <td>No. of cam pattern setting sections</td> <td>Setting range: 1 to 20 (sections) Any other settings will be errors.</td> </tr> </tbody> </table>	bit	Name	Description	15-0	No. of cam pattern setting sections	Setting range: 1 to 20 (sections) Any other settings will be errors.	●	●															
bit	Name	Description																									
15-0	No. of cam pattern setting sections	Setting range: 1 to 20 (sections) Any other settings will be errors.																									
-	UM 66F43	Shift amount	U0	<p>When reading, the shift amount of the read cam pattern table is stored. When rewriting, the shift amount of the rewritten cam pattern table is stored.</p> <table border="1"> <thead> <tr> <th>bit</th> <th>Name</th> <th>Description</th> </tr> </thead> <tbody> <tr> <td>15-0</td> <td>Shift amount</td> <td>Range: 0 to 100.00 (%) Any other settings will be errors.</td> </tr> </tbody> </table>	bit	Name	Description	15-0	Shift amount	Range: 0 to 100.00 (%) Any other settings will be errors.	●	●															
bit	Name	Description																									
15-0	Shift amount	Range: 0 to 100.00 (%) Any other settings will be errors.																									

# Specifications

●: Available, -: Not available

Axis no.	Unit memory no. (Hex)	Name	Default	Description	R	W						
-	UM 66F44	Start phase of section 1	U0	<p>When reading, the start phase in the section 1 of the read cam pattern table is stored. The read value is always 0.</p> <p>When rewriting, the start phase in the section 1 of the rewritten cam pattern table is set. When any value other than 0 is set in the section 1, it cannot be rewritten correctly.</p> <table border="1"> <thead> <tr> <th>bit</th> <th>Name</th> <th>Description</th> </tr> </thead> <tbody> <tr> <td>15-0</td> <td>Start phase</td> <td>Range: 0 to 10000 (0 to 100.00%) Any other settings will be errors.</td> </tr> </tbody> </table> <p>When reading, stores it truncating the numbers beyond the third decimal point. When rewriting, the numbers beyond the third decimal point are calculated in the unit and the result is registered.</p>	bit	Name	Description	15-0	Start phase	Range: 0 to 10000 (0 to 100.00%) Any other settings will be errors.	●	●
bit	Name	Description										
15-0	Start phase	Range: 0 to 10000 (0 to 100.00%) Any other settings will be errors.										
-	UM 66F45	Displacement of section 1	K0	<p>When reading, the displacement in the section 1 of the read cam pattern table is stored.</p> <p>When rewriting, the displacement in the section 1 of the rewritten cam pattern table is set.</p> <table border="1"> <thead> <tr> <th>bit</th> <th>Name</th> <th>Description</th> </tr> </thead> <tbody> <tr> <td>15-0</td> <td>Displacement</td> <td>Range: -10000 to +10000 (-100.00% to +100.00%) Any other settings will be errors.</td> </tr> </tbody> </table> <p>When reading, stores it truncating the numbers beyond the third decimal point. When rewriting, the numbers beyond the third decimal point are calculated in the unit and the result is registered.</p>	bit	Name	Description	15-0	Displacement	Range: -10000 to +10000 (-100.00% to +100.00%) Any other settings will be errors.	●	●
bit	Name	Description										
15-0	Displacement	Range: -10000 to +10000 (-100.00% to +100.00%) Any other settings will be errors.										



## 16.10 Unit Memories (Cam Pattern Editing Area)

●: Available, -: Not available

Axis no.	Unit memory no. (Hex)	Name	Default	Description	R	W						
-	UM 66F46	Cam curve of section 1	U0	<p>When reading, the cam curve of the read cam pattern table is stored. When rewriting, the cam curve of the rewritten cam pattern table is set.</p> <table border="1" style="width: 100%; border-collapse: collapse;"> <thead> <tr style="background-color: #e0e0e0;"> <th style="text-align: center;">bit</th> <th style="text-align: center;">Name</th> <th style="text-align: center;">Description</th> </tr> </thead> <tbody> <tr> <td style="text-align: center;">15-0</td> <td style="text-align: center;">Cam curve setting</td> <td>           10: Constant speed            11: Constant acceleration            12: Simple harmonic motion            22: Cycloid            25: Modified trapezoid            26: Modified sine            27: Modified uniform velocity            33: Asymmetric cycloid            34: Asymmetric modified trapezoid            35: Trapezoid            43: One-dwell cycloid m=1            44: One-dwell cycloid m=2/3            45: One-dwell modified trapezoid m=1            46: One-dwell modified trapezoid (Ferguson)            47: One-dwell modified trapezoid m=2/3            48: One-dwell modified sine            49: One-dwell trapezoid            No-dwell modified trapezoid            52: No-dwell modified uniform velocity            92: NC2 curve            Any other settings will be errors.         </td> </tr> </tbody> </table>	bit	Name	Description	15-0	Cam curve setting	10: Constant speed 11: Constant acceleration 12: Simple harmonic motion 22: Cycloid 25: Modified trapezoid 26: Modified sine 27: Modified uniform velocity 33: Asymmetric cycloid 34: Asymmetric modified trapezoid 35: Trapezoid 43: One-dwell cycloid m=1 44: One-dwell cycloid m=2/3 45: One-dwell modified trapezoid m=1 46: One-dwell modified trapezoid (Ferguson) 47: One-dwell modified trapezoid m=2/3 48: One-dwell modified sine 49: One-dwell trapezoid No-dwell modified trapezoid 52: No-dwell modified uniform velocity 92: NC2 curve Any other settings will be errors.	●	●
bit	Name	Description										
15-0	Cam curve setting	10: Constant speed 11: Constant acceleration 12: Simple harmonic motion 22: Cycloid 25: Modified trapezoid 26: Modified sine 27: Modified uniform velocity 33: Asymmetric cycloid 34: Asymmetric modified trapezoid 35: Trapezoid 43: One-dwell cycloid m=1 44: One-dwell cycloid m=2/3 45: One-dwell modified trapezoid m=1 46: One-dwell modified trapezoid (Ferguson) 47: One-dwell modified trapezoid m=2/3 48: One-dwell modified sine 49: One-dwell trapezoid No-dwell modified trapezoid 52: No-dwell modified uniform velocity 92: NC2 curve Any other settings will be errors.										
-	UM 66F47	Reserved for system	-	-	-	-						

## Specifications

●: Available, -: Not available

Axis no.	Unit memory no. (Hex)	Name	Default	Description	R	W
-	UM 66F48	Start phase of section 2	U0	Just like the area for the section 1, set the start phase, displacement and cam curve.	●	●
-	UM 66F49	Displacement of section 2	K0		●	●
-	UM 66F4A	Cam curve of section 2	U0		●	●
-	UM 66F4B	Reserved for system	-		-	-
-	UM 66F4C	Start phase of section 3	U0		●	●
-	UM 66F4D	Displacement of section 3	K0		●	●
-	UM 66F4E	Cam curve of section 3	U0		●	●
-	UM 66F4F	Reserved for system	-		-	-
-	UM 66F50	Start phase of section 4	U0		●	●
-	UM 66F51	Displacement of section 4	K0		●	●
-	UM 66F52	Cam curve of section 4	U0		●	●
-	UM 66F53	Reserved for system	-		-	-
-	UM 66F54	Start phase of section 5	U0		●	●
-	UM 66F55	Displacement of section 5	K0		●	●
-	UM 66F56	Cam curve of section 5	U0		●	●
-	UM 66F57	Reserved for system	-		-	-
-	UM 66F58	Start phase of section 6	U0		●	●
-	UM 66F59	Displacement of section 6	K0		●	●
-	UM 66F5A	Cam curve of section 6	U0		●	●
-	UM 66F5B	Reserved for system	-		-	-

## 16.10 Unit Memories (Cam Pattern Editing Area)

●: Available, -: Not available

Axis no.	Unit memory no. (Hex)	Name	Default	Description	R	W
-	UM 66F5C	Start phase of section 7	U0	Just like the area for the section 1, set the start phase, displacement and cam curve.	●	●
-	UM 66F5D	Displacement of section 7	K0		●	●
-	UM 66F5E	Cam curve of section 7	U0		●	●
-	UM 66F5F	Reserved for system	-		-	-
-	UM 66F60	Start phase of section 8	U0		●	●
-	UM 66F61	Displacement of section 8	K0		●	●
-	UM 66F62	Cam curve of section 8	U0		●	●
-	UM 66F63	Reserved for system	-		-	-
-	UM 66F64	Start phase of section 9	U0		●	●
-	UM 66F65	Displacement of section 9	K0		●	●
-	UM 66F66	Cam curve of section 9	U0		●	●
-	UM 66F67	Reserved for system	-		-	-
-	UM 66F68	Start phase of section 10	U0		●	●
-	UM 66F69	Displacement of section 10	K0		●	●
-	UM 66F6A	Cam curve of section 10	U0		●	●
-	UM 66F6B	Reserved for system	-		-	-
-	UM 66F6C	Start phase of section 11	U0		●	●
-	UM 66F6D	Displacement of section 11	K0		●	●
-	UM 66F6E	Cam curve of section 11	U0		●	●
-	UM 66F6F	Reserved for system	-		-	-

## Specifications

●: Available, -: Not available

Axis no.	Unit memory no. (Hex)	Name	Default	Description	R	W
-	UM 66F70	Start phase of section 12	U0	Just like the area for the section 1, set the start phase, displacement and cam curve.	●	●
-	UM 66F71	Displacement of section 12	K0		●	●
-	UM 66F72	Cam curve of section 12	U0		●	●
-	UM 66F73	Reserved for system	-		-	-
-	UM 66F74	Start phase of section 13	U0		●	●
-	UM 66F75	Displacement of section 13	K0		●	●
-	UM 66F76	Cam curve of section 13	U0		●	●
-	UM 66F77	Reserved for system	-		-	-
-	UM 66F78	Start phase of section 14	U0		●	●
-	UM 66F79	Displacement of section 14	K0		●	●
-	UM 66F7A	Cam curve of section 14	U0		●	●
-	UM 66F7B	Reserved for system	-		-	-
-	UM 66F7C	Start phase of section 15	U0		●	●
-	UM 66F7D	Displacement of section 15	K0		●	●
-	UM 66F7E	Cam curve of section 15	U0		●	●
-	UM 66F7F	Reserved for system	-		-	-
-	UM 66F80	Start phase of section 16	U0		●	●
-	UM 66F81	Displacement of section 16	K0		●	●
-	UM 66F82	Cam curve of section 16	U0		●	●
-	UM 66F83	Reserved for system	-		-	-

## 16.10 Unit Memories (Cam Pattern Editing Area)

●: Available, -: Not available

Axis no.	Unit memory no. (Hex)	Name	Default	Description	R	W
-	UM 66F84	Start phase of section 17	U0	Just like the area for the section 1, set the start phase, displacement and cam curve.	●	●
-	UM 66F85	Displacement of section 17	K0		●	●
-	UM 66F86	Cam curve of section 17	U0		●	●
-	UM 66F87	Reserved for system	-		-	-
-	UM 66F88	Start phase of section 18	U0		●	●
-	UM 66F89	Displacement of section 18	K0		●	●
-	UM 66F8A	Cam curve of section 18	U0		●	●
-	UM 66F8B	Reserved for system	-		-	-
-	UM 66F8C	Start phase of section 19	U0		●	●
-	UM 66F8D	Displacement of section 19	K0		●	●
-	UM 66F8E	Cam curve of section 19	U0		●	●
-	UM 66F8F	Reserved for system	-		-	-
-	UM 66F90	Start phase of section 20	U0		●	●
-	UM 66F91	Displacement of section 20	K0		●	●
-	UM 66F92	Cam curve of section 20	U0		●	●
-	UM 66F93	Reserved for system	-		-	-
-	UM 66F94 -UM 66F97	Reserved for system	-		-	-

### 16.10.3 Cam Pattern Editing Execution Area

●: Available, -: Not available

Axis no.	Unit memory no. (Hex)	Name	Default	Description	R	W
-	UM 66F98	Cam pattern reading result	H0	Stores the result of reading processing (response code). H0: Normal end Other than H0: Abnormal end	●	-
-	UM 66F99	Cam pattern rewriting result	H0	Stores the result of rewriting processing (response code). H0: Normal end Other than H0: Abnormal end	●	-

(Note): In the case of abnormal end, the codes in the following table are stored.

Code	Name	Description	Object		Countermeasures
			R	W	
H FF01	Cam pattern number setting error	Cam pattern no. The setting value is out of the range.	●	●	Check the set value of the cam pattern number.
H FF02	Number of cam pattern setting sections setting error	The set number of cam pattern setting sections is out of the settable range.	-	●	Check the set number of setting sections.
H FF03	Shift amount setting error	The set shift amount is out of the settable range.	-	●	Check the set value of the shift amount.
H FF05	Start phase setting error 1	The set start phase is out of the settable range.	-	●	Check the set value of the start phase in each section.
H FF06	Start phase setting error 2	The set start phase is the same as or smaller than the start phase of the previous section.	-	●	Check if the relation between the start phases of each section is (Start phase of section n-1) < (Start phase of section n).
H FF07	Start phase setting error 3	The set start phase of the section 1 is not 0.	-	●	Always set the start phase of the section 1 to 0.
H FF0A	Displacement setting error	The set value of the displacement is out of the settable range.	-	●	Check the set value of the phase in each section.
H FF0B	Cam curve number setting error	The set cam curve number is out of the settable range.	-	●	Check the set value of the cam curve number in each section.
H FF10	Cam pattern reading not executable error 1	An axis in synchronous operation exists.	●	-	Cancel the synchronous operation and execute the reading.
H FF11	Cam pattern reading not executable error 2	An operating axis exists.	●	-	Execute the reading when no operating axis exists.
H FF20	Cam pattern rewriting not executable error 1	An axis in synchronous operation exists.	-	●	Cancel the synchronous operation and execute the rewriting.
H FF21	Cam pattern rewriting not executable error 2	An operating axis exists.	-	●	Execute the rewriting when no operating axis exists.
H FF22	Cam pattern rewriting not executable error 3	The reading request and rewriting request turned on simultaneously.	-	●	Check if the reading request and rewriting request do not turn on simultaneously. When the reading request and writing request turn on simultaneously, the reading request takes priority.

## 16.10 Unit Memories (Cam Pattern Editing Area)

●: Available, -: Not available

Axis no.	Unit memory no. (Hex)	Name	Default	Description	R	W		
Cam patterns 1-16	UM 66F9A	Cam pattern update flag	HFFFF	Announces the valid cam pattern table data.		●	●	
				bit	Name			Description
				0	Cam no. 1 Valid condition			0: Cam pattern table after rewriting by user program is valid. 1: Configuration data by tool software (CMI) is valid.
				1	Cam no. 2 Valid condition			
				2	Cam no. 3 Valid condition			
				3	Cam no. 4 Valid condition			
				4	Cam no. 5 Valid condition			
				5	Cam no. 6 Valid condition			
				6	Cam no. 7 Valid condition			
				7	Cam no. 8 Valid condition			
				8	Cam no. 9 Valid condition			
				9	Cam no. 10 Valid condition			
				10	Cam no. 11 Valid condition			
				11	Cam no. 12 Valid condition			
				12	Cam no. 13 Valid condition			
				13	Cam no. 14 Valid condition			
				14	Cam no. 15 Valid condition			
15	Cam no. 16 Valid condition							

## 16.11 Unit Memories (SDO/PDO Communication Area)

### 16.11.1 Configuration of SDO/PDO Communication Area

Starting no.	Name	No. of words
UM 00000	Whole unit memory map	
UM 0007F UM 00080	System area	128 words
UM 0017F UM 00180	Input control area	256 words
UM 0027F UM 00280	Output control area	256 words
	Common area	9,104 words
UM 0260F UM 02610	System area	48 words
UM 0263F UM 02640	Each axis information area	3,072 words
UM 0323F UM 03240	Each axis setting area	396,480 words
UM 63EFF UM 63F00	System area	64 words
UM 63F3F UM 63F40	Synchronous control setting area	10,752 words
UM 6693F UM 66940	Positioning operation change setting area	1,536 words
UM 66F3F UM 66F40	Cam pattern editing area	106 words
UM 66FA9 UM 66FAA	System area	64 words
UM 7C4AF UM 7C4B0	SDO communication area	1,040 words
UM 7C8BF UM 7C8C0	PDO communication area	5,936 words
UM 7DFFB UM 7DFFC	System area	12 words
UM 7DFFD UM 7DFFE	Diagnosis mode communication area	2 words
UM 7FFFB UM 7FFFF	System area	8,193 words
	UM 7C4B0 SDO communication [header part] area	16 words
	UM 7C4C0 SDO communication [data part] area	1,024 words



## 16.11.2 SDO Communication Area

"SDO communication" is a function to perform communication between "Master (FP7 MC Unit)" and "Slave devices" by user programs.

●: Available, -: Not available

Axis no.	Unit memory no. (Hex)	Name	Default	Unit	Setting range and description	R	W
-	UM 7C4B0	Station Address	1	-	Station addresses of slave devices for SDO communication are set. Range: 1 to 192 When performing SDO communication with any setting values other than the above, an error (error code: 0001H) occurs. When specifying a node address that does not exist in the network, an error (error code: 0007H) occurs.	●	●
-	UM 7C4B1	Main-Index	0	-	The main index number of CoE object for SDO communication is set. Refer to CoE objects in respective manuals of slave devices.	●	●
-	UM 7C4B2	Sub-Index	0	-	The sub index number of CoE object for SDO communication is set. Refer to CoE objects in respective manuals of slave devices. When performing SDO communication with any setting values other than the above, an error (error code: 0002H) occurs.	●	●
-	UM 7C4B3	Data Type	0001H	-	The data type of CoE object for SDO communication is set. H1: Bool (1bit) H2: INT8 (1byte) H3: INT16 (1word) H4: INT32 (2words) H5: UINT8 (1byte) H6: UINT16 (1word) H7: UINT32 (2words) H8: - H9: STRING When performing SDO communication with any setting values other than the above, an error (error code: 0003H) occurs.	●	●

# Specifications

●: Available, -: Not available

Axis no.	Unit memory no. (Hex)	Name	Default	Unit	Setting range and description	R	W						
-	UM 7C4B4	Bit length	0	-	<p>When setting the data type to H9 (STRING) and performing SDO communication, the data unit (number of bytes) of CoE object data is set.</p> <table border="1"> <thead> <tr> <th>bit.</th> <th>Name</th> <th>Description</th> </tr> </thead> <tbody> <tr> <td>15-0</td> <td>Bit length</td> <td> <p>When reading: The number of bytes to be read from a slave device is set.</p> <p>When writing: The number of bytes to be written to a slave device is set.</p> <p>Setting range: 0x0000 to 0x03FF</p> </td> </tr> </tbody> </table>	bit.	Name	Description	15-0	Bit length	<p>When reading: The number of bytes to be read from a slave device is set.</p> <p>When writing: The number of bytes to be written to a slave device is set.</p> <p>Setting range: 0x0000 to 0x03FF</p>	●	●
bit.	Name	Description											
15-0	Bit length	<p>When reading: The number of bytes to be read from a slave device is set.</p> <p>When writing: The number of bytes to be written to a slave device is set.</p> <p>Setting range: 0x0000 to 0x03FF</p>											
-	UM 7C4B5	Command	0H	-	<p>Commands for SDO communication are set.</p> <table border="1"> <thead> <tr> <th>bit.</th> <th>Name</th> <th>Description</th> </tr> </thead> <tbody> <tr> <td>15-0</td> <td>Command</td> <td> <p>0000H: Initial state/processing done</p> <p>0001H: Read</p> <p>0081H: Write</p> <p>Any other settings will be errors.</p> </td> </tr> </tbody> </table>	bit.	Name	Description	15-0	Command	<p>0000H: Initial state/processing done</p> <p>0001H: Read</p> <p>0081H: Write</p> <p>Any other settings will be errors.</p>	●	●
bit.	Name	Description											
15-0	Command	<p>0000H: Initial state/processing done</p> <p>0001H: Read</p> <p>0081H: Write</p> <p>Any other settings will be errors.</p>											
-	UM 7C4B6	Result	0H	-	<p>SDO communication results are stored.</p> <table border="1"> <thead> <tr> <th>bit.</th> <th>Name</th> <th>Description</th> </tr> </thead> <tbody> <tr> <td>15-0</td> <td>Result</td> <td> <p>0000H: Normal end</p> <p>5555H: During processing (Waiting for response)</p> <p>FFFFH: Error occurs</p> <p>Any other settings will be errors.</p> </td> </tr> </tbody> </table>	bit.	Name	Description	15-0	Result	<p>0000H: Normal end</p> <p>5555H: During processing (Waiting for response)</p> <p>FFFFH: Error occurs</p> <p>Any other settings will be errors.</p>	●	-
bit.	Name	Description											
15-0	Result	<p>0000H: Normal end</p> <p>5555H: During processing (Waiting for response)</p> <p>FFFFH: Error occurs</p> <p>Any other settings will be errors.</p>											
-	UM 7C4B7	Timeout value	1H	0.1s	<p>The sending/receiving timeout monitor time (0.1 s) for SDO communication is set.</p> <p>Range: 1 to 2400 (0.1 s to 240 s)</p> <p>Any other settings will be errors.</p>	●	●						
-	UM 7C4B8 -UM 7C4B9	Error code	0H	-	<p>The result of reading/writing processing (response code) is stored.</p>	●	-						

## 16.11 Unit Memories (SDO/PDO Communication Area)

Error code	Name	Description
0000 0000H	Normal end	
0000 0001H	Station address setting value error	
0000 0002H	Sub index number setting value error	
0000 0003H	Data type setting value error	
0000 0005H	Command code setting value error	
0000 0006H	Timeout value setting value error	
0000 0007H	Station address setting value error (It does not exist in network.)	
0503 0000H	SDO abort code	Toggle bit did not change.
0504 0000H	SDO abort code	Timeout of SDO protocol
0504 0001H	SDO abort code	Client/server command code is invalid or unknown.
0504 0005H	SDO abort code	Out of memory
0601 0000H	SDO abort code	Access is not supported by object.
0601 0001H	SDO abort code	Attempted to read data from a write-only object.
0601 0002H	SDO abort code	Attempted to write data to a read-only object.
0602 0000H	SDO abort code	Object does not exist in object dictionary.
0601 0003H	SDO abort code	Sub index cannot be written, SIO must be 0 for write access.
0604 0041H	SDO abort code	Object cannot be allocated to PDO mapping.
0604 0042H	SDO abort code	The number of mapped objects or data length exceeded PDF limit.
0604 0043H	SDO abort code	Incompatibility of general parameters
0604 0047H	SDO abort code	Incompatibility of the inside of device
0606 0000H	SDO abort code	Access failure caused by hardware error
0607 0010H	SDO abort code	Data type mismatch, service parameter length mismatch
0607 0012H	SDO abort code	Data type mismatch. Service parameter length is too long.
0607 0013H	SDO abort code	Data type mismatch. Service parameter length is too short.
0609 0011H	SDO abort code	Sub index does not exist.
0609 0030H	SDO abort code	Out of the range of parameter value (Write access only)
0609 0031H	SDO abort code	Write parameter is large.
0609 0032H	SDO abort code	Write parameter is small.
0609 0036H	SDO abort code	Maximum value is smaller than minimum value.
0800 0000H	SDO abort code	General error
0800 0020H	SDO abort code	Data cannot be transferred to or stored in application.
0800 0021H	SDO abort code	Data cannot be transferred to or stored in application because of local control.
0800 0022H	SDO abort code	Application data cannot be transferred or stored in the current device state.
0800 0023H	SDO abort code	Object dictionary does not exist.

# Specifications

●: Available, -: Not available

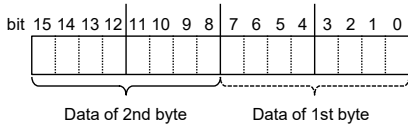
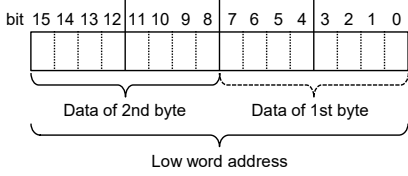
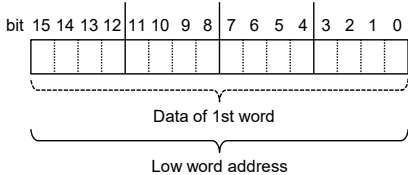
Axis no.	Unit memory no. (Hex)	Name	Default	Unit	Setting range and description	R	W
-	UM 7C4C0	Send/Receive data	0000H	-	<p>When reading: Data read from slave devices and executed is stored. When writing: Data written to slave devices and executed is stored.</p> <p>The order of data storage is as follows.</p> <p>Example) 2-byte data</p>  <p>Example) 4-byte data</p>  <p>Example) 2-word data</p> 	●	●
-	UM 7C4C1		0000H	-		●	●
-	UM 7C4C2		0000H	-		●	●
-	UM 7C4C3		0000H	-		●	●
-	UM 7C4C4		0000H	-		●	●
-	UM 7C4C5		0000H	-		●	●
-	UM 7C4C6		0000H	-		●	●
-	UM 7C4C7		0000H	-		●	●
-	UM 7C4C8		0000H	-		●	●
-	UM 7C4C9		0000H	-		●	●
-	UM 7C4CA		0000H	-		●	●
-	UM 7C4CB		0000H	-		●	●
-	UM 7C4CC		0000H	-		●	●
-	UM 7C4CD		0000H	-		●	●
-	UM 7C4CE		0000H	-		●	●
-	UM 7C4CF		0000H	-		●	●
-	UM 7C4D0		0000H	-		●	●
-	UM 7C4D1		0000H	-		●	●
-	UM 7C4D2		0000H	-		●	●
-	UM 7C4D3		0000H	-		●	●
-	UM 7C4D4		0000H	-		●	●
-	UM 7C4D5		0000H	-		●	●
-	UM 7C4D6		0000H	-		●	●
-	UM 7C4D7		0000H	-		●	●
-	UM 7C4D8		0000H	-		●	●
-	UM 7C4D9		0000H	-		●	●
-	UM 7C4DA		0000H	-		●	●
-	UM 7C4DB		0000H	-		●	●
-	:	0000H	-	●	●		
-	:	0000H	-	●	●		
-	:	0000H	-	●	●		
-	:	0000H	-	●	●		

## 16.11 Unit Memories (SDO/PDO Communication Area)

●: Available, -: Not available

Axis no.	Unit memory no. (Hex)	Name	Default	Unit	Setting range and description	R	W
-	:	Send/Receive data	0000H	-	When reading: Data read from slave devices and executed is stored. When writing: Data written to slave devices and executed is stored. The order of data storage is as follows.	●	●
-	:		0000H	-		●	●
-	:		0000H	-		●	●
-	:		0000H	-		●	●
-	UM 7C8A4		0000H	-	Example) 2-byte data	●	●
-	UM 7C8A5		0000H	-		●	●
-	UM 7C8A6		0000H	-	<div style="text-align: center;"> </div>	●	●
-	UM 7C8A7		0000H	-		●	●
-	UM 7C8A8		0000H	-	Example) 4-byte data	●	●
-	UM 7C8A9		0000H	-		●	●
-	UM 7C8AA		0000H	-	<div style="text-align: center;"> </div>	●	●
-	UM 7C8AB		0000H	-		●	●
-	UM 7C8AC		0000H	-	<div style="text-align: center;"> </div>	●	●
-	UM 7C8AD		0000H	-		●	●
-	UM 7C8AE		0000H	-	<div style="text-align: center;"> </div>	●	●
-	UM 7C8AF		0000H	-		●	●
-	UM 7C8B0		0000H	-	<div style="text-align: center;"> </div>	●	●
-	UM 7C8B1		0000H	-		●	●
-	UM 7C8B2		0000H	-	Example) 2-word data	●	●
-	UM 7C8B3		0000H	-		●	●
-	UM 7C8B4		0000H	-	<div style="text-align: center;"> </div>	●	●
-	UM 7C8B5		0000H	-		●	●
-	UM 7C8B6		0000H	-	<div style="text-align: center;"> </div>	●	●
-	UM 7C8B7		0000H	-		●	●
-	UM 7C8B8		0000H	-	<div style="text-align: center;"> </div>	●	●
-	UM 7C8B9		0000H	-		●	●
-	UM 7C8BA		0000H	-	<div style="text-align: center;"> </div>	●	●
-	UM 7C8BB		0000H	-		●	●
-	UM 7C8BC		0000H	-	<div style="text-align: center;"> </div>	●	●
-	UM 7C8BD		0000H	-		●	●
-	UM 7C8BE		0000H	-	<div style="text-align: center;"> </div>	●	●
-	UM 7C8BF		0000H	-		●	●

[1,024 words]

### 16.11.3 PDO Communication Area [RxPDO (Master -> Slave Devices)]

This area is used for FP7 MC Unit to send data stored in the addresses corresponding various slave devices for each Ethernet communication cycle.

●: Available, -: Not available

Axis no.	Unit memory no. (Hex)	Name	Default	Unit	Setting range and description	R	W
-	UM 7C8C0	PxPDO communication data area	-	-	<p>The order of data storage is as follows.</p> <p>Example) 2-byte data</p> <p>Example) 4-byte data</p> <p>Example) 2-word data</p> <p>Example) 2-word data</p> <p>[2,968 words]</p>	●	●
-	UM 7C8C1		●	●			
-	UM 7C8C2		●	●			
-	UM 7C8C3		●	●			
-	UM 7C8C4		●	●			
-	UM 7C8C5		●	●			
-	UM 7C8C6		●	●			
-	UM 7C8C7		●	●			
-	UM 7C8C8		●	●			
-	UM 7C8C9		●	●			
-	UM 7C8CA		●	●			
-	UM 7C8CB		●	●			
-	UM 7C8CC		●	●			
-	UM 7C8CD		●	●			
-	UM 7C8CE		●	●			
-	UM 7C8CF		●	●			
-	:		●	●			
-	:		●	●			
-	UM 7D44A		●	●			
-	UM 7D44B		●	●			
-	UM 7D44C		●	●			
-	UM 7D44D		●	●			
-	UM 7D44E		●	●			
-	UM 7D44F		●	●			
-	UM 7D450		●	●			
-	UM 7D451		●	●			
-	UM 7D452		●	●			
-	UM 7D453		●	●			
-	UM 7D454		●	●			
-	UM 7D455		●	●			
-	UM 7D456	●	●				
-	UM 7D457	●	●				

### 16.11.4 PDO Communication Area [TxPDO (Master <- Slave Devices)]

This area is used for FP7 MC Unit to store data received from various slave devices into the corresponding addresses for each EtherCAT communication cycle.

●: Available, -: Not available

Axis no.	Unit memory no. (Hex)	Name	Default	Unit	Setting range and description	R	W
-	UM 7D458	TxPDO communication data area	-	-	<p>The order of data storage is as follows.</p> <p>Example) 2-byte data</p> <p>Example) 4-byte data</p> <p>Example) 2-word data</p>	●	-
-	UM 7D459		●	-			
-	UM 7D45A		●	-			
-	UM 7D45B		●	-			
-	UM 7D45C		●	-			
-	UM 7D45D		●	-			
-	UM 7D45E		●	-			
-	UM 7D45F		●	-			
-	UM 7D460		●	-			
-	UM 7D461		●	-			
-	UM 7D462		●	-			
-	UM 7D463		●	-			
-	UM 7D464		●	-			
-	UM 7D465		●	-			
-	UM 7D466		●	-			
-	UM 7D467		●	-			
-	UM 7D468		●	-			
-	UM 7D469		●	-			
-	UM 7D46A		●	-			
-	UM 7D46B		●	-			
-	UM 7D46C		●	-			
-	UM 7D46D		●	-			
-	UM 7D46E		●	-			
-	UM 7D46F		●	-			
-	UM 7D470		●	-			
-	UM 7D471		●	-			
-	UM 7D472		●	-			
-	:		●	-			
-	:	●	-				
-	:	●	-				
-	:	●	-				

# Specifications

●: Available, -: Not available

Axis no.	Unit memory no. (Hex)	Name	Default	Unit	Setting range and description	R	W
-	:	TxPDO communication data area	-	-	The order of data storage is as follows. Example) 2-byte data	●	-
-	:		-	-		●	-
-	:		-	-		●	-
-	:		-	-		●	-
-	UM 7DFD3		-	-		●	-
-	UM 7DFD4		-	-		●	-
-	UM 7DFD5		-	-		●	-
-	UM 7DFD6		-	-		●	-
-	UM 7DFD7		-	-		●	-
-	UM 7DFD8		-	-		●	-
-	UM 7DFD9		-	-		●	-
-	UM 7DFDA		-	-		●	-
-	UM 7DFDB		-	-		●	-
-	UM 7DFDC		-	-		●	-
-	UM 7DFDD		-	-		●	-
-	UM 7DFDE		-	-		●	-
-	UM 7DFDF		-	-		●	-
-	UM 7DFE0		-	-		●	-
-	UM 7DFE1		-	-		●	-
-	UM 7DFE2		-	-		●	-
-	UM 7DFE3		-	-		●	-
-	UM 7DFE4		-	-		●	-
-	UM 7DFE5		-	-		●	-
-	UM 7DFE6		-	-		●	-
-	UM 7DFE7		-	-		●	-
-	UM 7DFE8		-	-		●	-
-	UM 7DFE9		-	-		●	-
-	UM 7DFEA		-	-		●	-
-	UM 7DFEB	-	-		●	-	
-	UM 7DFEC	-	-		●	-	
-	UM 7DFED	-	-		●	-	
-	UM 7DFEE	-	-		●	-	
-	UM 7DFEF	-	-	 [2,968 words]	●	-	



## 16.12 Reference "ASCII Codes"

								b7									
								b6	0	0	0	0	1	1	1	1	
								b5	0	0	1	1	0	0	1	1	
								b4	0	1	0	1	0	1	0	1	
b7	b6	b5	b4	b3	b2	b1	b0	R	C	0	1	2	3	4	5	6	7
0	0	0	0	0	0	0	0	0	NUL	DEL	SPACE	0	@	P	`	p	
0	0	0	1	1	1	1	1	1	SOH	DC <sub>1</sub>	!	1	A	Q	a	q	
0	0	1	0	0	0	0	0	2	STX	DC <sub>2</sub>	"	2	B	R	b	r	
0	0	1	1	1	1	1	1	3	ETX	DC <sub>3</sub>	#	3	C	S	c	s	
0	1	0	0	0	0	0	0	4	EOT	DC <sub>4</sub>	\$	4	D	T	d	t	
0	1	0	1	1	1	1	1	5	ENQ	NAK	%	5	E	U	e	u	
0	1	1	0	0	0	0	0	6	ACK	SYN	&	6	F	V	f	v	
0	1	1	1	1	1	1	1	7	BEL	ETB	'	7	G	W	g	w	
1	0	0	0	0	0	0	0	8	BS	CAN	(	8	H	X	h	x	
1	0	0	1	1	1	1	1	9	HT	EM	)	9	I	Y	i	y	
1	0	1	0	0	0	0	0	A	LF	SUB	*	:	J	Z	j	z	
1	0	1	1	1	1	1	1	B	VT	ESC	+	;	K	[	k	{	
1	1	0	0	0	0	0	0	C	FF	FS	,	<	L	¥	l		
1	1	0	1	1	1	1	1	D	CR	GS	-	=	M	]	m	}	
1	1	1	0	0	0	0	0	E	SO	RS	.	>	N	^	n	~	
1	1	1	1	1	1	1	1	F	SI	US	/	?	O	_	o	DEL	

## 16.13 Dimensions

---

■ AFP7MC16EC/ AFP7MC32EC/ AFP7MC64EC

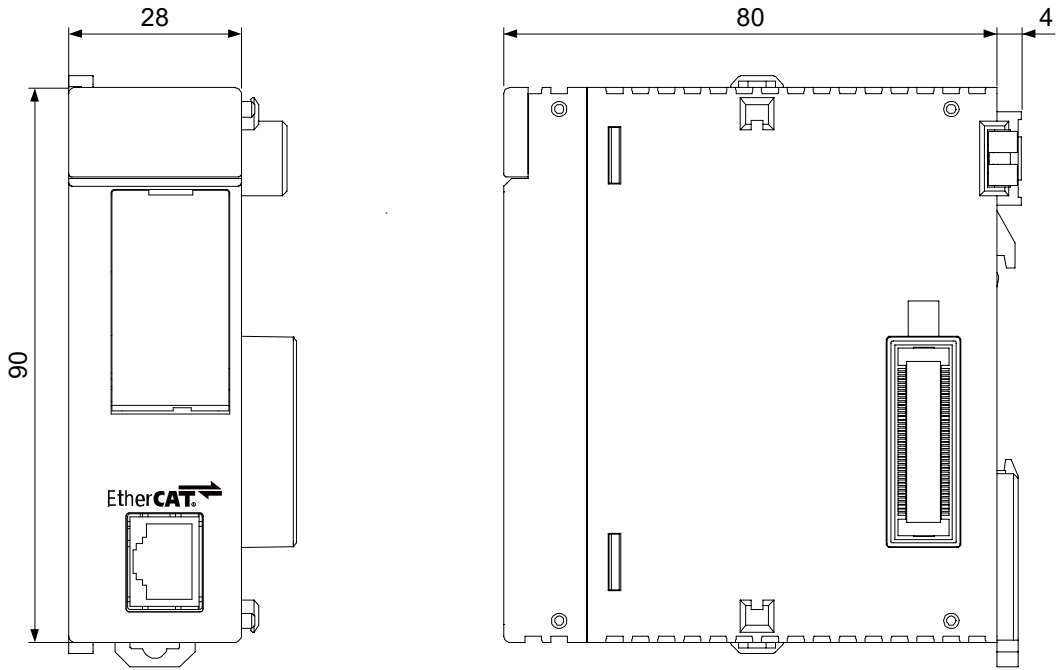

(Unit: mm)

# Record of changes

Manual No.	Date	Record of Changes
<p>WUME-FP7MCEC-01 WUME-FP7MCEC-02</p>	<p>Sep. 2016 Nov. 2017</p>	<p>1st Edition</p> <p>2nd Edition</p> <p>Added functions supported by FP7 MC Unit Ver.1.2.</p> <ul style="list-style-type: none"> <li>● Supports Servo Amplifier A6B.</li> <li>● Added slave devices compatible with EtherCAT. (SC-GU3-03, SL-VG1-EC, encoder devices)</li> <li>● Supports revision check.</li> <li>● SDO/PDO communication by user programs, change of ESM, and clearance of errors in slave devices.</li> <li>● Added node address (ID) discrimination methods (CMI tool setting/Slave device setting).</li> <li>● Supports extended positioning tables.</li> <li>● Supports movement amount and actual speed monitor value (2-word data).</li> <li>● Speed change and movement amount change when axes are operating.</li> <li>● Switching deceleration stop and pause operation by user programs.</li> <li>● Torque limit</li> <li>● Electronic clutch: Clutch phase match OFF</li> <li>● Electronic cam: Advance angle correction function and editing by user programs.</li> <li>● Cancelling slave axes when a master axis is operating.</li> <li>● Synchronous deceleration method: S-shaped deceleration</li> <li>● Time chart monitor (Data logging)</li> <li>● Comment storage to the Unit.</li> </ul> <p>Added described items.</p> <ul style="list-style-type: none"> <li>● AMP error codes and warning codes</li> </ul> <p>Corrected the descriptions of functions supported by FP7 MC Unit Ver.1.2.</p> <ul style="list-style-type: none"> <li>● Change of speed reference range.</li> <li>● Change of control cycle.</li> <li>● Added notes regarding slave devices compatible with EtherCAT (SC-GU3-03).</li> </ul> <p>Error correction</p>

Manual No.	Date	Record of Changes
WUME-FP7MCEC-03	Jan. 2019	<p>3rd Edition</p> <p>Upgrade</p> <ul style="list-style-type: none"><li>● Added notes on node address setting</li><li>● Added error codes</li><li>● Added multi-turn data clearing method</li><li>● Added AMP parameter saving method</li><li>● Added the method for delaying EtherCAT communication startup after power ON</li><li>● Error correction on positioning movement amount change function movement amount</li></ul>



---

Please contact .....

## Panasonic Industrial Devices SUNX Co., Ltd.

■ Overseas Sales Division (Head Office): 2431-1 Ushiyama-cho, Kasugai-shi, Aichi, 486-0901, Japan

■ Telephone: +81-568-33-7861 ■ Facsimile: +81-568-33-8591

[panasonic.net/id/pidsx/global](http://panasonic.net/id/pidsx/global)

About our sale network, please visit our website.