

Appendix A Wiring examples

A.1 AX7x-C-1608P high-speed I/O

A.1.1 Wiring example of CH0-CH5

High-speed I/O CH0-CH5 support single-ended and differential signal input, and do not share common terminals. The following takes encoder connection as an example to describe the high-speed I/O interfaces and wiring methods when the output interface types are NPN, PNP, push-pull and differential respectively.

1) When the encoder output interface type is NPN, the wiring method is as follows:

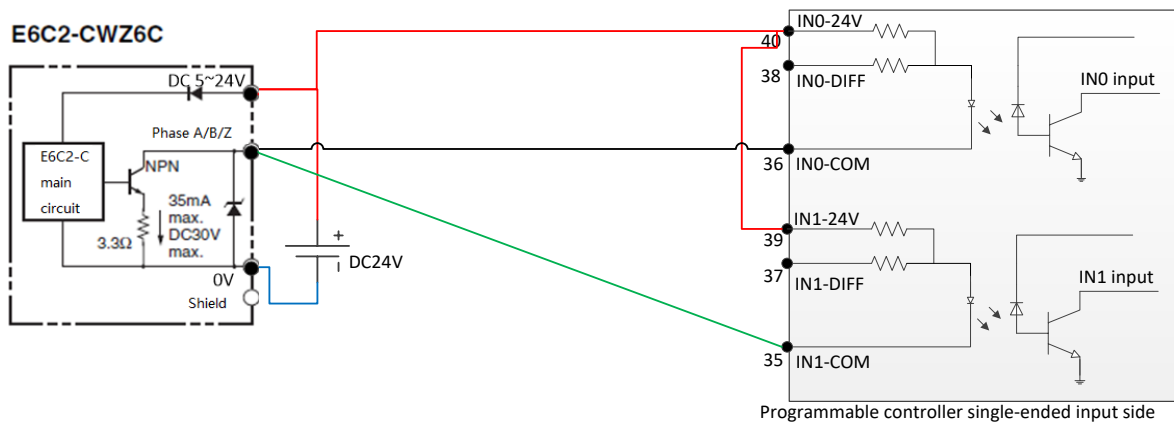

The preceding figure shows that phases A and B of the encoder whose output interface type is NPN are respectively output to CH0 and CH1 of the programmable controller CPU module.

2) When the encoder output interface is PNP, the wiring method is as follows:

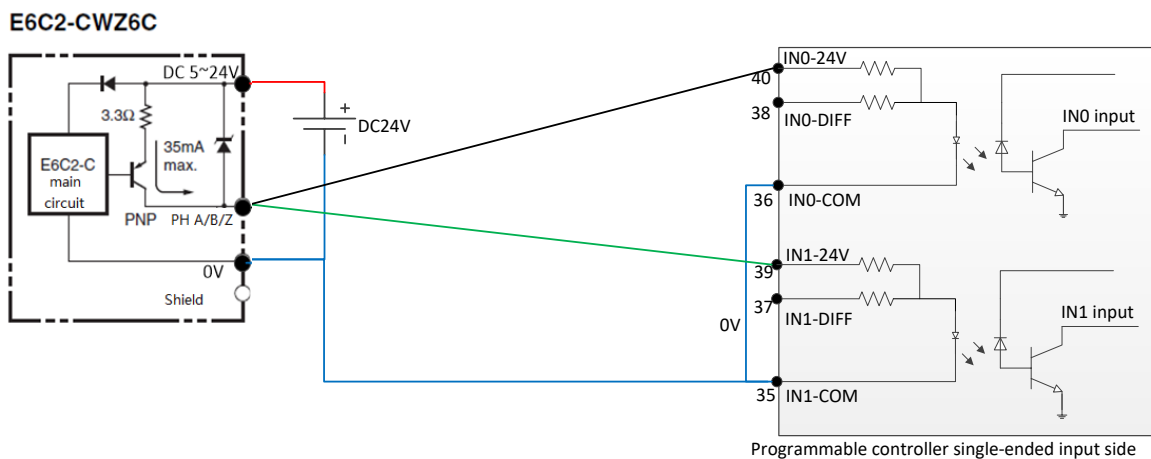

The preceding figure shows that phases A and B of the encoder whose output interface type is PNP are respectively output to CH0 and CH1 of the programmable controller CPU module.

3) When the encoder output interface type is push-pull, the wiring method is as follows:

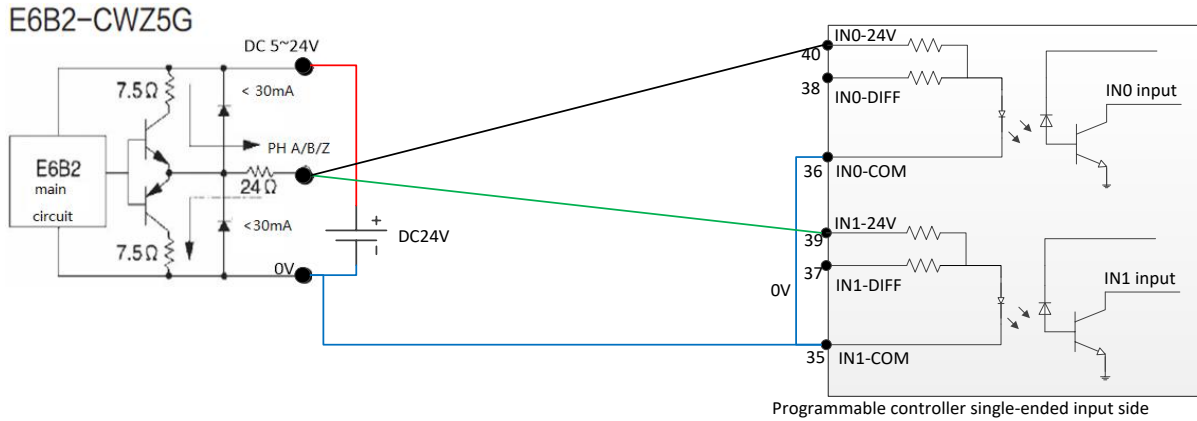

The preceding figure shows that phases A and B of the encoder whose output interface type is push-pull are respectively output to CH0 and CH1 of the programmable controller CPU module.

4) When the encoder output interface type is differential, the wiring method is as follows:

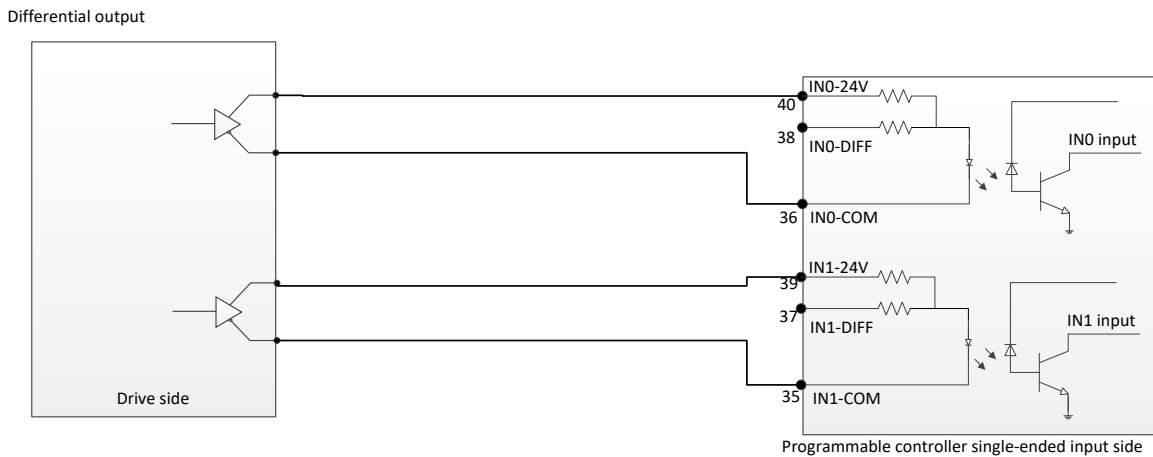

The preceding figure shows that phases A and B of the encoder whose output interface type is differential are respectively output to CH0 and CH1 of the programmable controller CPU module.

It is recommended to use the encoder with differential signal output, which can further improve the anti-interference performance of the equipment in hostile environments.

A.1.2 Wiring example of CH6–CH15

High-speed I/O CH6–CH15 support only single-ended signal input, among which CH6, CH8, CH10, CH12, and CH14 share common terminal SS1, while CH7, CH9, CH11, CH13, and CH15 share common terminal SS2. The following takes encoder connection as an example to describe the high-speed I/O interfaces and wiring methods when the output interface types are NPN, PNP, and push-pull respectively.

1) When the encoder output interface type is NPN, the wiring method is as follows:

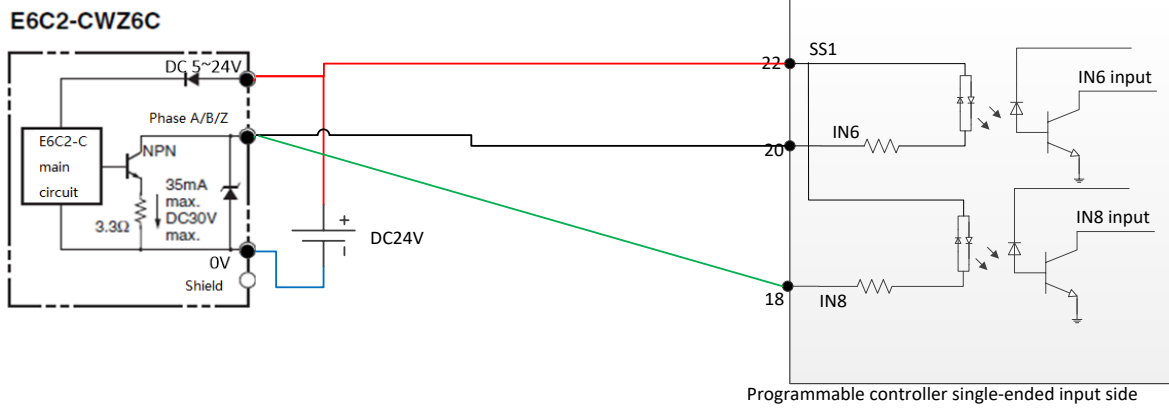

The preceding figure shows that phases A and B of the encoder whose output interface type is NPN are respectively output to CH6 and CH8 of the programmable controller CPU module.

2) When the encoder output interface type is PNP, the wiring method is as follows:

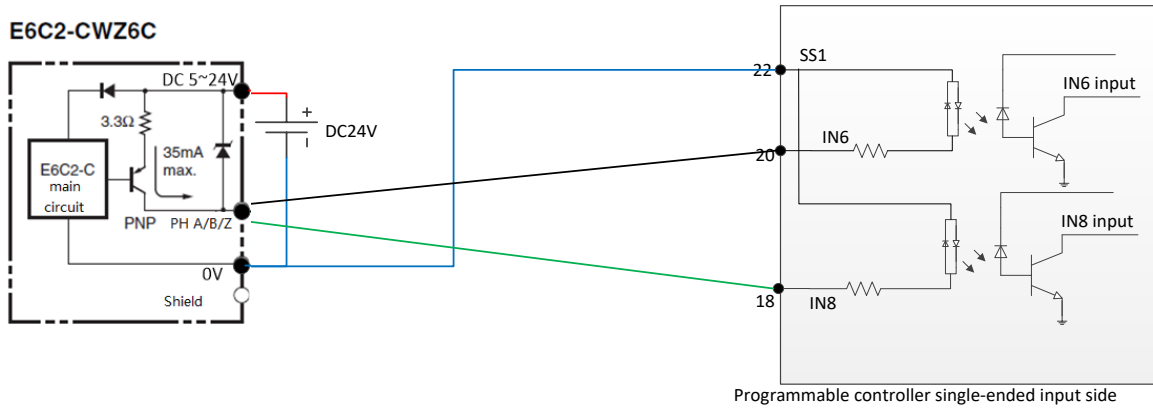

The preceding figure shows that phases A and B of the encoder whose output interface type is PNP are respectively output to CH6 and CH8 of the programmable controller CPU module.

3) When the encoder output interface type is push-pull, the wiring method is as follows:

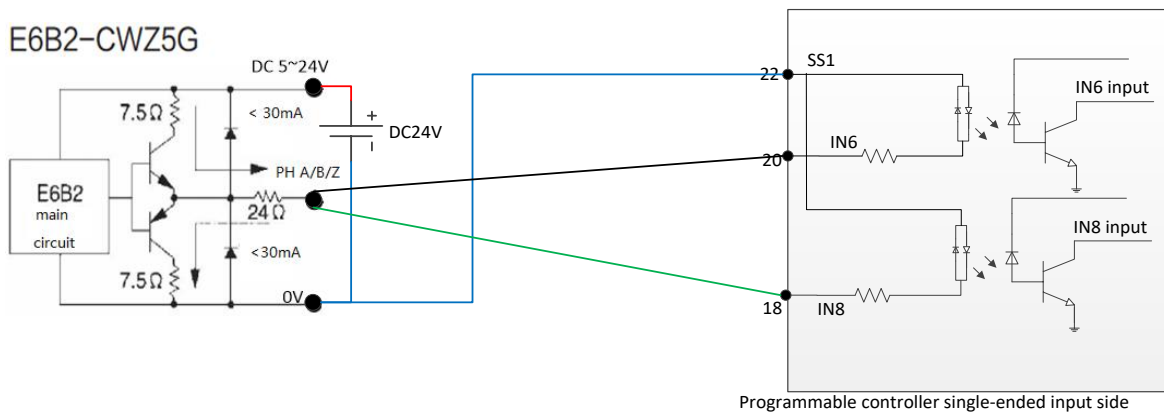

Note: The wiring method is similar to that for the encoder whose output interface type is PNP.

A.1.3 Output wiring example

There are 8 channels of high-speed output signal, supporting only single-ended output. OUT0, OUT2, OUT4, and OUT6 share common terminal COM1, while OUT1, OUT3, OUT5, and OUT7 share common terminal COM2. The following figure takes drive optocoupler as an example to describe the high-speed output interfaces and wiring methods.

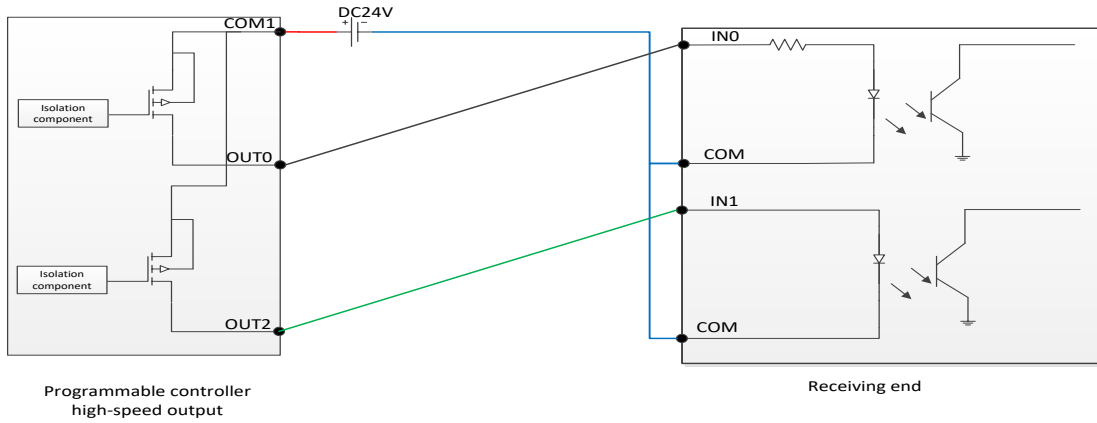

A.2 AX-EM-1600D digital input module

AX-EM-1600D digital input module has 16 inputs, sharing a common terminal. The following figure takes photosensor as an example to describe the wiring methods when the output interface types are NPN and PNP respectively.

1) When the photosensor output interface type is NPN, the wiring method is as follows:

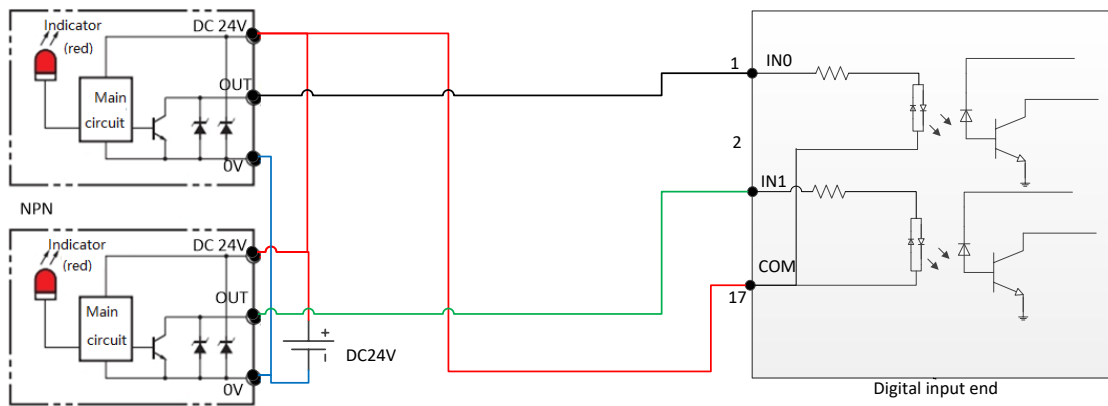

2) When the photosensor output interface type is PNP, the wiring method is as follows:

